



Planning Commission Staff Report

Meeting Date: January 2, 2024

Agenda Item: 8D

MASTER PLAN AMENDMENT CASE NUMBER: WMPA23-0008 & WRZA23-0009
(Thompson Family Trust)

BRIEF SUMMARY OF REQUEST: Request to change the Master Plan and regulatory zone designation of 8.36 acres of two parcels totaling 81.83 acres from Rural to Suburban Residential and General Rural to Low Density Suburban, respectively.

STAFF PLANNER: Kat Oakley, Planner
Phone Number: 775.328.3628
E-mail: koakley@washoecounty.gov

CASE DESCRIPTION

For hearing, discussion, and possible action to ...

- (1) Approve an amendment to the Southwest Truckee Meadows Area Plan, a component of the Washoe County Master Plan, to redesignate 8.36 acres of two parcels totaling 81.83 acres from Rural (R) to Suburban Residential (SR); and,
- (2) Subject to final approval of the associated Master Plan Amendment by the Board of County Commissioners and a finding of conformance with the Truckee Meadows Regional Plan by regional planning authorities, recommend adoption of an amendment to the Southwest Truckee Meadows Regulatory Zone Map, to redesignate 8.36 acres of the same parcels from General Rural (GR) (1 dwelling unit/40 acres) to Low Density Suburban (LDS) (1 du/acre); and
- (3) If approved, authorize the chair to sign resolutions to this effect.

Applicant: David Thompson
 Property Owner: Thompson Family Trust
 Location: Southeast of intersection of Hunters Peak Rd and Hunter Falls Cir
 APN: 041-650-04 & 041-650-05
 Parcel Size: 41.56 & 40.27 acres
 Existing Master Plan: Rural (R)
 Proposed Master Plan: Rural (R) and Suburban Residential (SR)
 Existing Regulatory Zone: General Rural (GR)
 Proposed Regulatory Zone: General Rural (GR) and Low-Density Suburban (LDS)
 Area Plan: Southwest Truckee Meadows
 Development Code: Authorized in Article 820, Amendment of Master Plan &

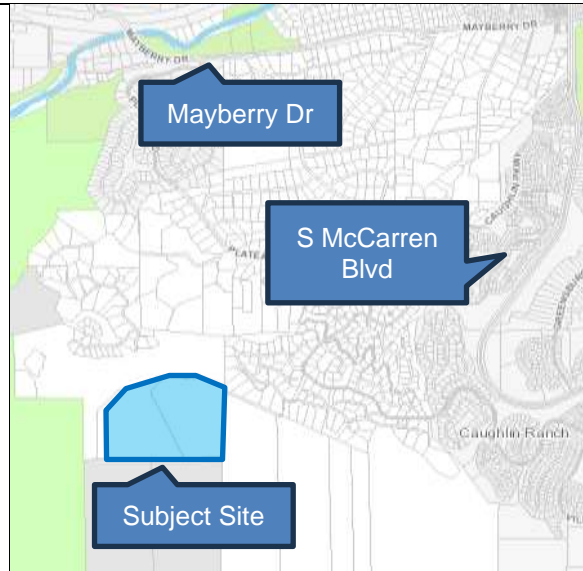

Vicinity Map

| | | |
|----------------------|--|--|
| Commission District: | Article 821, Amendment of Regulatory Zone 1 – Commissioner Hill | |
|----------------------|--|--|

STAFF RECOMMENDATION—Master Plan Amendment

APPROVE

DENY

POSSIBLE MOTION

I move that, after giving reasoned consideration to the information contained in the staff report and information received during the public hearing, the Washoe County Planning Commission deny Master Plan Amendment Case Number WMPA23-0006 being unable to make the required findings in accordance with Washoe County Code Section 110.820.15(d) [specify particular findings that cannot be made] and with policies SW.20.1 and SW.20.3 of the Southwest Truckee Meadows Area Plan.

(Motion with Findings on Pages 17)

STAFF RECOMMENDATION – Regulatory Zoning Amendment

APPROVE

DENY

POSSIBLE MOTION

I move that, after giving reasoned consideration to the information contained in the staff report and information received during the public hearing, the Planning Commission recommend denial of Regulatory Zone Amendment Case Number WRZA23-0006, being unable to make the required findings in accordance with Washoe County Code Section 110.821.15 [specify particular findings that cannot be made].

(Motion with Findings on Page 19)

Staff Report Contents

Explanation of a Master Plan Amendment 4

Existing and Proposed Master Plan Designations 4

Explanation and Processing of a Regulatory Zone Amendment..... 5

Existing and Proposed Regulatory Zoning Designations 6

Background..... 6

Development Constraints 9

Area Plan Evaluation.....10

Master Plan Evaluation10

Regional Plan Evaluation11

Findings—Master Plan Amendment.....12

Findings—Regulatory Zone Amendment.....16

Neighborhood Meeting.....17

Public Notice17

Recommendation—Master Plan Amendment17

Recommended Motion—Master Plan Amendment.....17

Recommendation—Regulatory Zone Amendment19

Recommended Motion—Regulatory Zone Amendment19

Alternative Motion—Master Plan Amendment.....20

Alternative Motion—Regulatory Zone Amendment.....21

Appeal Process.....22

Attachment Contents

Master Plan Amendment Resolution Exhibit A

Regulatory Zone Amendment Resolution..... Exhibit B

Notice Map..... Exhibit C

Agency Comments..... Exhibit D

Neighborhood Meeting Summary..... Exhibit E

Application Exhibit F

MPA Side-by-Side..... Exhibit G

RZA Side-by-Side Exhibit H

Explanation of a Master Plan Amendment

The purpose of a Master Plan Amendment application is to provide a method of review for requests to amend the master plan.

The Master Plan guides growth and development in the unincorporated areas of Washoe County and consists of three volumes. By establishing goals and implementing those goals through policies and action programs, the Master Plan addresses issues and concerns both countywide and within each community. Master Plan Amendments ensure that the Master Plan remains timely, dynamic, and responsive to community values. The Washoe County Master Plan can be accessed on the Washoe County Planning website at https://www.washoecounty.gov/csd/planning_and_development, and then select Master Plan & Maps - or it may be obtained at the front desk of the Washoe County Planning and Building Division.

Master Plan Amendments require a change to the Master Plan and are processed in accordance with Washoe County Chapter 110 (Development Code), Article 820, *Amendment of Master Plan*.

When making a recommendation to the Washoe County Board of County Commissioners to adopt a Master Plan Amendment, the Planning Commission must make at least three of the five findings as set forth in Washoe County Code (WCC) Section 110.820.15(d). If a military installation is required to be noticed, then an additional finding of fact pursuant to WCC Section 110.820.15(d)(6) is required. If there are findings relating to Master Plan Amendments contained in the Area Plan in which the subject property is located, then the Planning Commission must also make all of those findings. A recommendation to adopt the Master Plan Amendment requires an affirmative vote of at least 2/3 of the Planning Commission's total membership.

Existing and Proposed Master Plan Designations

The applicant is asking to amend the Southwest Truckee Meadows Area Plan to redesignate 8.36 acres of two parcels (APN's 041-650-04 and 041-650-05) totaling 81.83 acres from Rural (R) to Suburban Residential (SR). As a result, 73.47 acres of the parcels would remain Rural, and 8.36 acres would be Suburban Residential (herein referred to as "project area"). See Figure 1, Existing and Proposed Master Plan Designations.

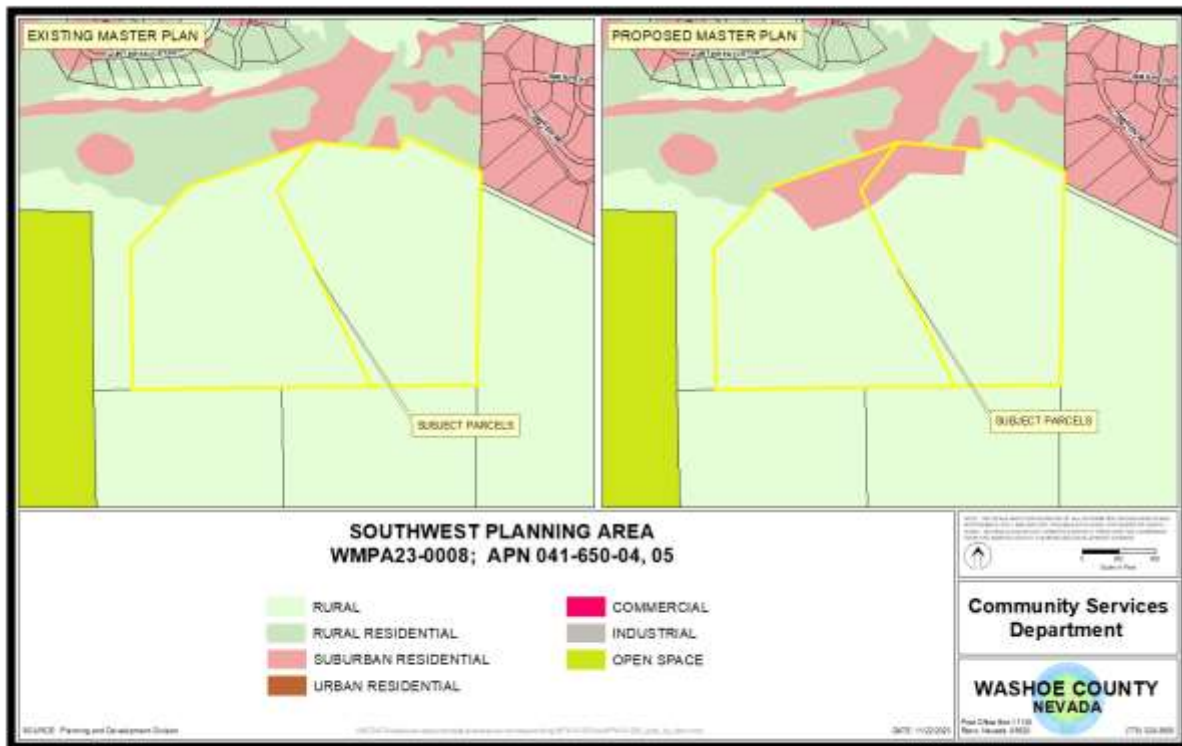

Figure 1
Existing and Proposed Master Plan Designations

Explanation and Processing of a Regulatory Zone Amendment

The purpose of a Regulatory Zone Amendment (RZA) is to provide a method for amending the regulatory zone maps of Washoe County. The regulatory zone maps depict the regulatory zones (i.e., zoning) adopted for each property within the unincorporated area of Washoe County. The regulatory zones establish the uses and development standards applied to each property.

Regulatory zones are designed to implement and be consistent with the Master Plan by ensuring that the stability and character of the community will be preserved for those who live and work in the unincorporated areas of the county. A regulatory zone cannot be changed if it conflicts with the objectives or policies of the Master Plan, including area plans that further define policies for specific communities. The Master Plan is the blueprint for development within the unincorporated County. Pursuant to NRS Chapter 278, any action of the County relating to zoning must conform to the Washoe County Master Plan.

Additionally, evaluation of a Regulatory Zone Amendment includes review of the proposed amendment against the findings found in Article 821 of the Washoe County Development Code and any findings as set forth in the appropriate Area Plan.

Requests to change a regulatory zone affecting a parcel of land or a portion of a parcel are processed under Article 821, Amendment of Regulatory Zone, of the Washoe County Development Code. Rezoning or reclassification of a lot or parcel from one regulatory zone to another requires action by both the Planning Commission and the Board of County Commissioners.

The Planning Commission may deny a Regulatory Zone Amendment, or it may recommend approval or modification of an amendment to the Board of County Commissioners. Upon an affirmative recommendation by the Planning Commission, the Board of County Commissioners

is required to hold a public hearing which must be noticed pursuant to Section 110.821.20 of the Washoe County Development Code. Final action is taken by the Board of County Commissioners who may adopt, adopt with modifications, or deny the proposed amendment.

Existing and Proposed Regulatory Zoning Designations

The second part of the applicant’s request is to change the regulatory zone of 8.36 acres of the same parcels from General Rural (GR) to Low Density Suburban (LDS). As a result, 73.47 acres would remain GR and 8.36 acres would be LDS. The locations of the GR and LDS zoning would mimic that of the R and SR master plan designations respectively. See Figure 2 - Existing and Proposed Zoning Designations.

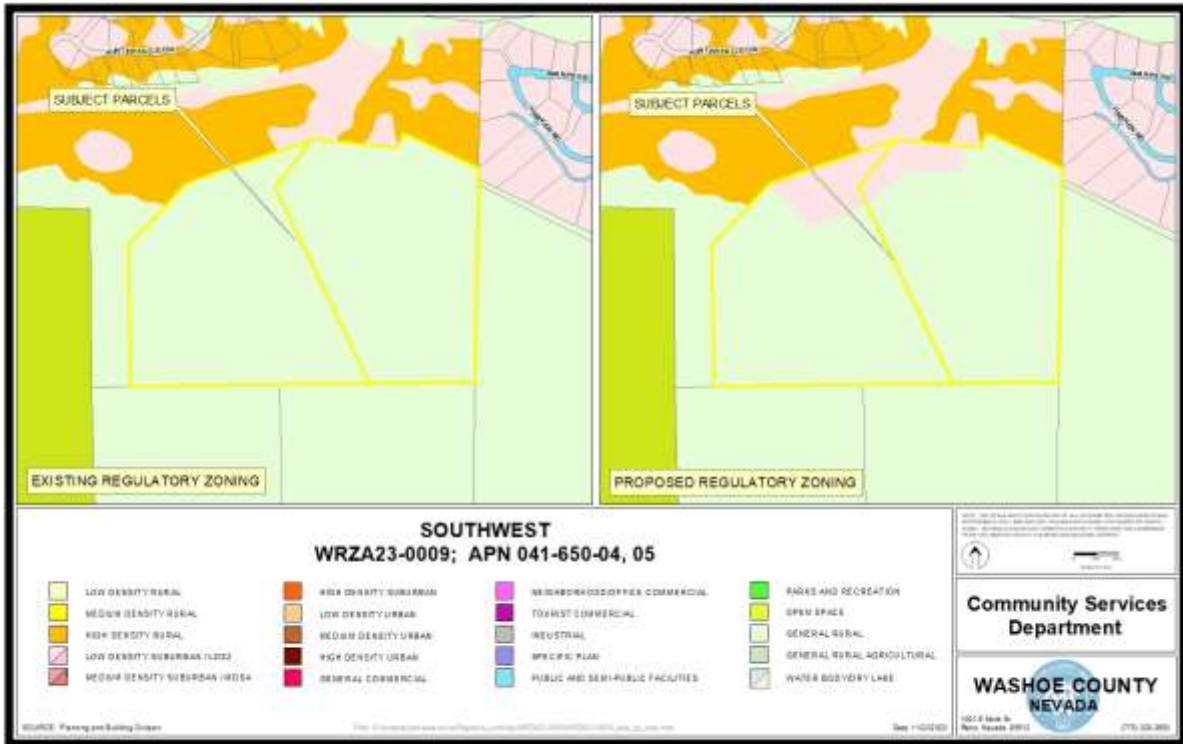

**Figure 2
Existing and Proposed Zoning Designations**

Background

The project area is currently vacant and borders undeveloped GR parcels to the south and east, and an undeveloped parcel within the Ridges at Hunter Creek Subdivision to the north and west. National Forest Land begins about 260 feet west of the subject properties and extends into the Mount Rose Wilderness. Parcels to the north are zoned LDS and High Density Rural (HDR), and parcels on all other sides are zoned GR. All surrounding property zoned GR is undeveloped. The subject properties are currently zoned GR.

The intent of the MPA/RZA is to allow for a future residential subdivision. If approved, the overall allowable density would increase from 2 units to 9 units. This represents an intensification of land use but does not exceed densities to the north. Zoning on all other sides is GR, which allows 1 unit per 40 acres. The land use intensification is located along the northern side of both parcels.

The parcel is encumbered by significant development constraints, namely extremely steep slopes. Most of both parcels are composed of slopes over 30%, including some areas that the applicant is proposing to rezone. For this and other reasons, as will be expanded on later in this staff report, staff is recommending the denial of both requests.

Compatible Land Uses

In determining compatibility with surrounding land uses, staff reviewed the Land Use Compatibility Matrix with the proposed Regulatory Zone Amendments. The compatibility matrix is found in the Land Use and Transportation Element in Volume One of the Washoe County Master Plan. The compatibility between the proposed and existing adjacent regulatory zones is captured in the table below.

Compatibility Rating of Proposed Regulatory Zone with Existing Regulatory Zones on Adjacent Parcels

| Existing Regulatory Zone | Proposed Regulatory Zone | Existing Adjacent Regulatory Zone | Current Compatibility | Proposed Compatibility Rating |
|--------------------------|--------------------------|-----------------------------------|-----------------------|-------------------------------|
| GR | GR/LDS | <u>North</u> : LDS/HDR | Medium | Medium/High/Identical |
| GR | GR/LDS | <u>East</u> : GR/LDS | Identical/Medium | Identical/Medium |
| GR | GR/LDS | <u>South</u> : GR | Identical | Identical/Medium |
| GR | GR/LDS | <u>West</u> : GR | Identical | Identical/Medium |

High Compatibility: Little or no screening or buffering necessary.
Medium Compatibility: Some screening and buffering necessary.
Low Compatibility: Significant screening and buffering necessary.

Overall, this request has little impact on land use compatibility. It decreases compatibility with surrounding GR parcels and increases compatibility with Ridges at Hunter Creek, to the north. The zoning configuration generally locates zoning designations next to the compatible districts on surrounding parcels.

Availability of Facilities

The subject property falls within the Truckee Meadows Service Area (“TMSA”) boundary and when developed, will be required to be on public water and sewer systems. Truckee Meadows Fire Station 40 is about 5 miles from the project site. The project would be served by Caughlin Ranch Elementary School, Swope Middle School, and Reno High School. The Washoe County School District did not indicate any capacity concerns at those schools.

The applicant has indicated that the Truckee Meadows Water Authority (TMWA) will serve the project and that wastewater would go to a City of Reno sewer treatment facility. Currently, water and sewer facilities do not extend to the project site. If the adjacent development to the north—Ridges at Hunter Creek—is completed, those facilities would extend closer to the project site. However, such facilities do not exist and are not planned within the next ten years. Appropriate facilities would be required to be constructed at the time of tentative map review.

Policy PF 1 of the Truckee Meadows Regional Plan requires facilities to meet certain standards within the TMSA. They are addressed below:

| Facility/Service | Standards in the TMSA | Staff Response |
|------------------|--|---|
| Water | Water conveyance facilities are: • Available and adequate; or | Water conveyance facilities are neither available nor |

| | | |
|--|--|---|
| | <ul style="list-style-type: none"> Planned for within a 10-year timeframe in facilities plans; and/or Required to be constructed by new development per the local government master plan | planned within a 10-year timeframe. They would be required to be constructed at the time of development and therefore fulfill this requirement. |
| Wastewater | <p>Sewer collection facilities are:</p> <ul style="list-style-type: none"> Available and adequate; or Planned for within a 10-year timeframe in facilities plans; or Required to be constructed by new development per the local government master plan. <p>Sewer treatment facilities are:</p> <ul style="list-style-type: none"> Available and adequate; or Planned for within a 10-year timeframe in facilities plans; and Supported by sewer connection fees | Sewer collection facilities are neither available nor planned within a 10-year timeframe. They would be required to be constructed prior to approval of a final map. Sewer treatment facilities are available and adequate. |
| Flood Control and Stormwater Drainage Management | Comply with RWMP floodplain and drainage policies. | Any future development of the subject site would be required to comply with all applicable RWMP floodplain and drainage policies. |
| Transportation | <ul style="list-style-type: none"> Multi-modal connectivity should be provided to existing or planned public transit Regional Road facilities are: Available and adequate; Planned for within the first 10 years in facilities plans; or Exempted from regional LOS standards in the adopted RTP. | Local roadways are not currently extended to the project site and are planned with the development of Ridges at Hunter Creek. They are not available or planned for within a 10-year time frame. They would be required to be constructed by the developer. The closest bus stop is at 4 th St. and Twin Lakes Dr., approximately 3.2 miles from the project site. |
| School | <p>School facilities are:</p> <ul style="list-style-type: none"> Available and adequate; or Planned for in the most current adopted WCSD Facilities Plan. | School facilities are available and adequate. |

The Washoe County Water Rights Manager, Nevada Division of Water Resources, and Washoe County Health District reviewed this application and did not have any concerns. The Truckee Meadows Regional Planning Agency (TMRPA) has indicated concerns that water, wastewater, and roadway facilities are insufficient. Washoe County has no plans to extend the necessary facilities to the subject site. If Ridges at Hunter Creek is completed and facilities are built at a sufficient capacity, then facilities would be adequate. However, there is no guarantee of that occurring. Staff therefore is unable to find that the facilities are available and adequate or planned to be adequate for the proposed density.

Development Constraints

The subject property is composed approximately 64% of slopes in excess of 30%, with very few areas that are less than 15%. The applicant has provided a slope analysis showing their envisioned future lot layout:

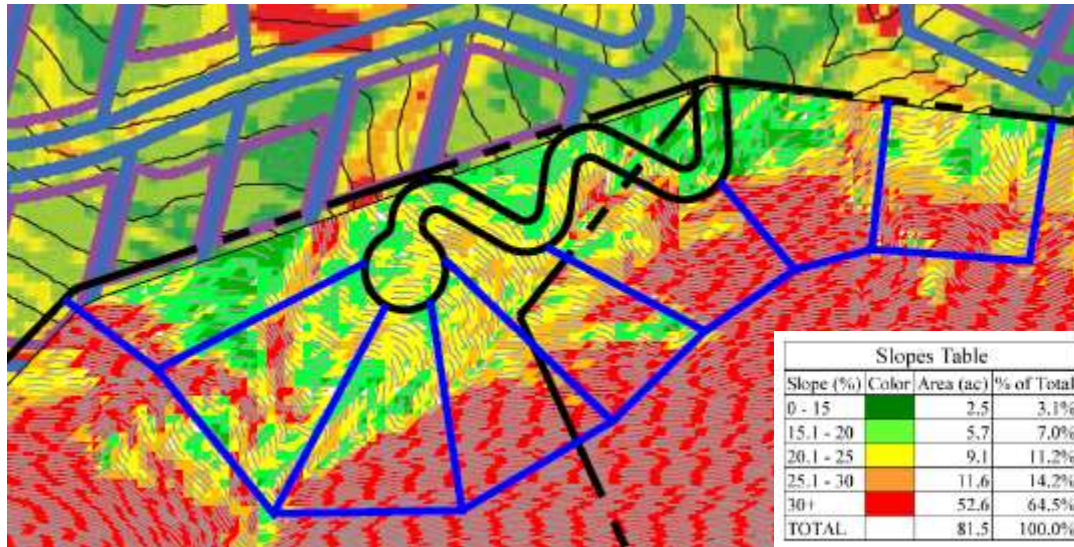

The blue proposed lot lines also represent the extent of proposed LDS zoning. While the area with the proposed zoning change is overall on a flatter portion of the site, it does encroach onto the steeper hillside and contains 2.1 acres, or approximately 25%, of slopes in excess of 30%. This includes encroachments into the TMRPA development constraints area (DCA):



Both the Washoe County Master Plan and Washoe County Development Code are clear that areas with slopes steeper than 30% are not suitable for development. WCC 110.106.15(a) specifies the purpose of the General Rural regulatory zone, which includes developmentally constrained areas that are suitable for agricultural/grazing operations rather than development. This includes areas with moderate (15% or greater) to steep (30% or greater) slopes. Further,

Article 424 Hillside Development is dedicated to parcels with moderate to steep slopes and specifies slopes steeper than 30% as less suitable for development in WCC 110.424.20(c)(1).

The master plan similarly contemplates areas with steep slopes. Part of the stated intent of the Rural and Rural Residential master plan categories in the Land Use and Transportation Element is "...to discourage suburban sprawl into areas that lack essential infrastructure and services for intensification, or that have resource constraints such as steep slopes." The Open Space and Natural Resource Conservation Plan indicates that slopes over 30% are not suitable for development. While residential development may be appropriate in the flatter portions of the project site, it is not on areas with steep slopes. The Washoe County Master Plan also recognizes the DCA area of the regional plan, as outlined in policy LUT.32.2:

"The DCA consists of playas, significant water bodies, natural slopes over 30%, publicly owned open space, and properties that are deed restricted to prevent development. Constrained lands less than 1/3 acre in size will not be included in the DCA. The DCA overlay takes precedence over otherwise applicable policies describing the desired density and intensity of development within the Truckee Meadows Service Areas and the Rural Development Area."

The proposed change to LDS regulatory zone and the Suburban Residential master plan category encroaches into the DCA area and into slopes steeper than 30%. Staff therefore is unable to find that the proposal conforms with the master plan.

Area Plan Evaluation

The subject parcel is located within the Southwest Truckee Meadows Area Plan. The following are the pertinent policies from the Area Plan:

Relevant Area Plan Policies Reviewed

| Policy | Brief Policy Description | Complies | Comments |
|---------|--|----------|---|
| SW.7.1 | All Master Plan Amendments shall be reviewed by the Nevada Department of Conservation and Natural Resources (DCNR) and an archaeological study conducted if requested. | Yes. | The Nevada State Historic Preservation Office (SHPO)—part of the DCNR—reviewed this proposal and had no comments. |
| SW.12.1 | The Nevada Department of Wildlife (NDOW) shall have the opportunity to comment on Master Plan Amendments. | Yes. | NDOW reviewed this proposal and had no comments. |
| SW.20.1 | Required findings for amendment to area plan. | No. | See analysis in Master Plan Amendment findings. |
| SW.20.3 | Required findings for amendment to land use designation in area plan. | No. | See analysis in Master Plan Amendment findings. |

Master Plan Evaluation

The Master Plan indicates that slopes over 30% are not suitable for development, as discussed in the development constraints section of this staff report. The following addresses other applicable policies of the Master Plan:

LUT.1.4 Residential should be within close proximity to retail/commercial land uses within the TMSA to facilitate both walking and cycling as desirable and safe modes of transportation.

Staff Comment: The proposed increase in residential density is within the TMSA but not in close proximity to retail/commercial land uses.

Regional Plan Evaluation

The parcel is currently designated as Tier 3 in the Truckee Meadows Regional Plan. In order for this proposal to be in conformance with the Regional Plan, a Regional Plan amendment to redesignate the project area to Tier 2 would be required. Table 3.1 in the Regional Plan identifies the density requirements for each tier:

| Regional Land Designation | Minimum Density (dwelling units per acre) | Maximum Density (du/ac) | Nonresidential Standards |
|---------------------------|---|------------------------------------|---|
| Mixed Use Core | 14 du/ac | No maximum | 0.25 floor-area ratio (FAR) minimum |
| Tier 1 Land | Existing | No maximum | None |
| Tier 2 Land | No minimum | 30 du/ac | None |
| Tier 3 Land | No minimum | Existing | Existing – Commercial development to support the surrounding neighborhood may be allowed in certain instances |
| Rural Area | N/A | 1 unit per 5 acres, see policy RF6 | Dispersed nonresidential uses per Policy RF6 |

As indicated above, a tier change is necessary for any intensification of the master plan land use on the subject parcels. The regional plan amendment would need to be initiated by the Board of County Commissioners (BCC). Regional planning staff would assess conformance with their policies at that time and determine if a regional plan amendment is appropriate.

Reviewing Agencies

The following agencies/individuals received a copy of the project application for review and evaluation. Some provided comments and the Washoe County Engineering Division recommended denial.

| Agencies | Sent to Review | Responded | Provided Conditions | Contact |
|--|----------------|-----------|---------------------|---|
| FS - Carson Ranger District | X | | | |
| FS - State Office, Humboldt-Toiyabe Nat'l Forest | X | | | |
| NDF - Endangered Species | X | | | |
| NDOW (Wildlife) | X | X | | Katie Andrle, kmandrle@ndow.org |
| NV Water Resources | X | X | | Steve Shell, sshell@water.nv.gov |
| Washoe County GIS | X | X | | Moni Fox, mfox@washoecounty.gov |
| Washoe County Parks & Open Space | X | X | | Faye-Marie Pekar, fpekar@washoecounty.gov |
| Washoe County Sewer | X | | | |
| Washoe County Traffic | X | | | |
| Washoe County Water Resource Planning | X | | | |
| Washoe County Water Rights Manager (All Apps) | X | X | | Timber Weiss, tweiss@washoecounty.gov |
| Washoe County Engineering (Land Development) (All Apps) | X | X | | Janelle Thomas, jkthomas@washoecounty.gov; Rob Wimer, rwimer@washoecounty.gov |
| Washoe County Engineering & Capital Projects Director (All Apps) | X | | | |
| NNPH Air Quality | X | | | |
| NNPH Environmental Health | X | X | | James English, jenglish@nnph.org |
| TMFPD | X | X | | Brittany Lemon, blemon@tmfpd.us |
| Truckee Meadows Regional Planning | X | X | | Chris Tolley, ctolley@tmrpa.org |
| Washoe-Storey Conservation District | X | X | | Jim Shaffer, shafferjam51@gmail.com |
| Regional Transportation Commission | X | | | |
| Nevada State Historic Preservation | X | | | |
| Truckee Meadows Water Authority | X | | | |

Findings—Master Plan Amendment

WCC Section 110.820.15(d) requires the Planning Commission to make at least three of the five findings of fact to recommend approval of the amendments to the Washoe County Board of County Commissioners. The following findings and staff comments on each finding are presented for the Planning Commission’s consideration:

1. Consistency with Master Plan. The proposed amendment is in substantial compliance with the policies and action programs of the Master Plan.

Staff Comment: The proposed amendments are not in substantial compliance with the policies and action programs of the Master Plan. As described on pages 9-11 of this staff report, the master plan considers lands with slopes over 30% to be developmentally constrained and not suitable for development. The intensification of residential land use on those areas would therefore not be appropriate or in alignment with the master plan. Furthermore, as described in the Master Plan Evaluation and Area Plan Evaluation

sections of this staff report, there are policies in the Southwest Truckee Meadows Area Plan and the elements of the Master Plan with which the proposal does not comply. Staff cannot make this finding.

2. Compatible Land Uses. The proposed amendment will provide for land uses compatible with (existing or planned) adjacent land uses, and will not adversely impact the public health, safety or welfare.

Staff Comment: The proposed amendment is at least partially compatible with surrounding land uses. Properties to the north—where the land use intensification is proposed—contain suburban residential lands. Properties to the south are designated rural, in alignment with the southern portion of the subject parcels. However, the Washoe County Engineering Division has concerns regarding the suitability of the site for safe development. Specifically, they have concerns that the steep slopes could be developed in a way that meets all safety standards. The proposed amendment therefore may adversely affect public safety or welfare. The site is simply not suitable for development at the density proposed. Staff cannot make this finding.

3. Response to Change Conditions. The proposed amendment responds to changed conditions or further studies that have occurred since the plan was adopted by the Board of County Commissioners, and the requested amendment represents a more desirable utilization of land.

Staff Comment: Since the adoption of the Southwest Truckee Meadows Area Plan, demand for housing in Washoe County has increased. Furthermore, a Master Plan Amendment to the north was approved which enabled a clustered hillside development that extended infrastructure closer to the project site. However, given the development constraints on the areas proposed to be designated Suburban Residential, this particular amendment does not represent a more desirable utilization of land.

4. Availability of Facilities. There are or are planned to be adequate transportation, recreation, utility, and other facilities to accommodate the uses and densities permitted by the proposed master plan designation.

Staff Comment: Adequate facilities to serve the intensification do not currently exist and are not planned by Washoe County. Facilities will be extended closer to the project site if a final map is completed for the approved tentative map to the north. However, there is no guarantee that it will be or that the completed facilities will be appropriately sized to accommodate this development. Staff cannot make this finding.

5. Desired Pattern of Growth. The proposed amendment will promote the desired pattern for the orderly physical growth of the County and guides development of the County based on the projected population growth with the least amount of natural resource impairment and the efficient expenditure of funds for public services.

Staff Comment: The proposed development extends into the development constraints area, which is not suitable for development. Density intensification in areas of steep slopes have greater impacts on natural resources, including scenic resources. Intensification in developmentally constrained areas is not the desired pattern of orderly physical growth in the county, as expressed in the Washoe County Master Plan and in the Washoe County Development Code. Staff cannot make this finding.

The following findings are required to be made per Area Plan policy SW.20.1:

- a. The amendment will further implement and preserve the Vision and Character Statement.

Staff Comment: The proposal largely aligns with the Vision and Character Statement of the Southwest Truckee Meadows Area Plan but conflicts with statements regarding the importance of protecting natural and scenic resources by encroaching into the development constraints area. The amendment would therefore not further implement and preserve the Vision and Character Statement.

- b. The amendment conforms to all applicable policies of the SWTM Area Plan and the Washoe County Master Plan, and the Regional Water Management Plan.

Staff Comment: The amendment does not conform with all applicable policies, particularly of the Washoe County Master Plan. As described in the development constraints section of this staff report, slopes in excess of 30% are not suitable for development and are intended by the master plan to be designated at a density of not greater than 1 unit per 40 acres (General Rural regulatory zone). Staff therefore cannot make this finding.

- c. The amendment will not conflict with the public's health, safety or welfare.

Staff Comment: The amendment may conflict with the public's health, safety, or welfare. The Washoe County Engineering Division reviewed this proposal and indicated that the slopes of the proposed LDS area are too steep for safe development at that density. This finding cannot be made.

The following findings are required to be made per Area Plan policy SW.20.3, as applicable:

- a. The impacts of the amendment are within commonly accepted thresholds of sustainable resource management and the county's ability to manage the conservation of the area's character will not be compromised.

Staff Comment: As described in the response to SW.20.1(a), encroachment into the development constraints area is not aligned with the area's character as articulated in the Southwest Area Plan.

- b. A feasibility study has been conducted, commissioned and paid for by the applicant, relative to municipal water, sewer and storm water that clearly identifies the improvements likely to be required to support the intensification, and those improvements have been determined to be in substantial compliance with all applicable existing facilities and resource plans for SWTM by the Department of Water Resources. The Department of Water Resources will establish and maintain the standards and methodologies for these feasibility studies.

Staff Comment: A feasibility study was conducted by the applicant regarding improvements for municipal water, sewer, and storm water that would be required for the proposed intensification. Any future improvements would be required to comply with all applicable codes and standards.

- c. A traffic analysis has been conducted that clearly identifies the impact of the adopted level of service within the Southwest Truckee Meadows planning area and the improvements likely to be required to maintain/achieve the adopted level of service. This finding may be waived by the Department of Public Works for projects that are determined to have minimal impacts. The Department of Public Works may request any information it deems necessary to make this determination.

Staff Comment: The proposal will have minimal traffic impacts and a traffic analysis was not conducted. The Washoe County Engineering Division reviewed this application and did not indicate that an analysis is necessary at this time.

- e. For residential land use intensifications, the potential increase in residential units will not exceed Washoe County's applicable policy growth level for the SWTM Area Plan, as established under Goal One.

Staff Comment: The intensification would not exceed Washoe County's applicable policy growth level established under Goal One of the SWTM Area Plan.

- f. If the proposed intensification will result in a drop below the established policy level of service for transportation (as established by the Regional Transportation Commission and Washoe County) within the Southwest Truckee Meadows planning area, the necessary improvements required to maintain the established level of service are scheduled in either the Washoe County Capital Improvements Program or Regional Transportation Improvement Program within three years of approval of the intensification. For impacts to regional roads, the Washoe County Planning Commission, upon written request from the Regional Transportation Commission, may waive this finding.

Staff Comment: The proposed intensification will have no significant impact on traffic or level of service. This finding is therefore not applicable.

- g. If roadways impacted by the proposed intensification are currently operating below adopted levels of service, the intensification will not require infrastructure improvements beyond those articulated in Washoe County and regional transportation plans AND the necessary improvements are scheduled in either the Washoe County Capital Improvements Program or Regional Transportation Improvement Program within three years of approval of the intensification.

Staff Comment: The Washoe County Engineering Division reviewed this proposal and indicated no concerns about the current levels of service of roadway operation.

- h. Proposed amendments shall complement the long-range plans of facilities providers for transportation, water resources, schools and parks as reflected in the policy growth level established in Policy 1.2.

Staff Comment: The proposed amendments would require the extension of water and wastewater facilities to the project site. These expansions are not contemplated by long range facilities plans and would be funded by the applicant.

- i. If the proposed intensification results in existing public school facilities exceeding design capacity and compromises the Washoe County School District's ability to implement the neighborhood school philosophy for elementary facilities, then there must be a current capital improvement plan or rezoning plan in place that would enable the District to absorb the additional enrollment. The Washoe County Planning Commission, upon request of the Washoe County School Board of Trustees, may waive this finding.

Staff Comment: The Washoe County School District reviewed this proposal and did not indicate any concerns regarding capacity.

- j. Any existing development in the Southwest Truckee Meadows planning area, the South Valleys planning area, the Forest planning area, or the Southeast Truckee Meadows planning area which is subject to the conditions of a special use permit will not experience undue hardship in its ability to continue to comply with the conditions of the special use permit or otherwise to continue operation of its permitted activities.

Staff Comment: The only special use permit on an adjoining parcel is for grading as part of the Ridges at Hunter Creek development. This proposal would not impact that special use permit.

Findings—Regulatory Zone Amendment

WCC Section 110.821.15(d) of Article 821, *Amendment of Regulatory Zone*, requires that all of the following findings be made to the satisfaction of the Washoe County Planning Commission before recommending adoption to the Board of County Commissioners. Staff has completed an analysis of the Regulatory Zone Amendment application and has determined that the proposal is not in compliance with all the required findings as follows:

1. The proposed amendment is in substantial compliance with the policies and action programs of the Master Plan and the Regulatory Zone Map.

Staff Comment: An analysis of the compliance with the master plan is in this staff report. As described above, the proposed Regulatory Zone Amendment does not comply with the master plan. It proposes to intensify residential density in developmentally constrained areas, which is in contravention of policies within the master plan. This finding cannot be made.

2. The proposed amendment will provide for land uses compatible with (existing or planned) adjacent land uses, and will not adversely impact the public health, safety or welfare.

Staff Comment: The proposed amendment is largely compatible with surrounding land uses. A portion of property to the north—where the land use intensification is proposed—contains Low Density Suburban lands. Properties to the south are designated General Rural, in alignment with the southern portion of the subject parcels. However, the Washoe County Engineering Division has concerns regarding the suitability of the site for safe development. Specifically, they have concerns that the steep slopes can be developed in a way that meets all safety standards. The proposed amendment therefore may adversely affect public safety or welfare. The site is not suitable for development at the density proposed. Staff cannot make this finding.

3. The proposed amendment responds to changed conditions or further studies that have occurred since the plan was adopted by the Board of County Commissioners, and the requested amendment represents a more desirable utilization of land.

Staff Comment: Since the adoption of the Southwest Truckee Meadows Area Plan, demand for housing in Washoe County has increased. Furthermore, a Master Plan Amendment to the north was approved which enabled a clustered hillside development that extended infrastructure closer to the project site. However, given the development constraints on the areas proposed to be designated Low Density Suburban, this particular amendment does not represent a more desirable utilization of land. Staff cannot make this finding.

4. There are or are planned to be adequate transportation, recreation, utility, and other facilities to accommodate the uses and densities permitted by the proposed amendment.

Staff Comment: Adequate facilities to serve the intensification do not currently exist and are not planned by Washoe County. Facilities will be extended closer to the project site if

a final map is completed for the approved tentative map to the north. However, there is no guarantee that it will be or that the completed facilities will be appropriately sized to accommodate this development. Staff cannot make this finding.

5. The proposed amendment will not adversely affect the implementation of the policies and action programs of the Washoe County Master Plan.

Staff Comment: An analysis of the compliance with the master plan is in this staff report. As described above, the proposed Regulatory Zone Amendment does not comply with the master plan. It proposes to intensify residential density in developmentally constrained areas, which is in contravention of policies within the master plan. Staff cannot make this finding.

6. The proposed amendment will promote the desired pattern for the orderly physical growth of the County and guides development of the County based on the projected population growth with the least amount of natural resource impairment and the efficient expenditure of funds for public services.

Staff Comment: The proposed development extends into the development constraints area, which is not suitable for development. Density intensification in areas of steep slopes have greater impacts on natural resources, including scenic resources. Intensification in developmentally constrained areas is not the desired pattern of orderly physical growth in the county, as expressed in the Washoe County Master Plan and in the Washoe County Development Code. Accordingly, staff cannot make this finding.

Neighborhood Meeting

NRS 278.210(2) and WCC Section 110.820.20 require a neighborhood meeting for any proposed Master Plan Amendment. The neighborhood meeting was held via Zoom on August 28, 2023, from 5:30 – 6:10 pm. Two people attended and asked questions about the process and future envisioned layout of parcels and building pads.

Public Notice

Notice for Master Plan Amendments must be given in accordance with the provisions of Nevada Revised Statutes 278.210(1), as amended and WCC Section 110.820.23. Notice was provided in a newspaper of general circulation within Washoe County at least 10 days before the public hearing date. A legal ad was placed with the Reno Gazette Journal for December 22, 2023.

Recommendation—Master Plan Amendment

It is recommended that the Washoe County Planning Commission deny the proposed Master Plan, being unable to make the findings required. The following motion is provided for your consideration:

Recommended Motion—Master Plan Amendment

I move that, after giving reasoned consideration to the information contained in the staff report and information received during the public hearing, the Washoe County Planning Commission deny Master Plan Amendment Case Number WMPA23-0008, being unable to make the required findings in accordance with Washoe County Code Section 110.820.15(d) [specify particular findings that cannot be made] and with policies SW.20.1 and SW.20.3 of the Southwest Truckee Meadows Area Plan. The findings in WCC 110.820.15(d) include:

1. Consistency with Master Plan. The proposed amendment is in substantial compliance with the policies and action programs of the Master Plan.

2. Compatible Land Uses. The proposed amendment will provide for land uses compatible with (existing or planned) adjacent land uses, and will not adversely impact the public health, safety or welfare.
3. Response to Change Conditions. The proposed amendment responds to changed conditions or further studies that have occurred since the plan was adopted by the Board of County Commissioners, and the requested amendment represents a more desirable utilization of land.
4. Availability of Facilities. There are or are planned to be adequate transportation, recreation, utility, and other facilities to accommodate the uses and densities permitted by the proposed Master Plan designation.
5. Desired Pattern of Growth. The proposed amendment will promote the desired pattern for the orderly physical growth of the County and guides development of the County based on the projected population growth with the least amount of natural resource impairment and the efficient expenditure of funds for public services.

The following findings in Area Plan policy SW.20.1 include:

- a. The amendment will further implement and preserve the Vision and Character Statement.
- b. The amendment conforms to all applicable policies of the SWTM Area Plan and the Washoe County Master Plan, and the Regional Water Management Plan.
- c. The amendment will not conflict with the public's health, safety or welfare.

The following findings in Area Plan policy SW.20.3 include:

- a. The impacts of the amendment are within commonly accepted thresholds of sustainable resource management and the county's ability to manage the conservation of the area's character will not be compromised.
- b. A feasibility study has been conducted, commissioned and paid for by the applicant, relative to municipal water, sewer and storm water that clearly identifies the improvements likely to be required to support the intensification, and those improvements have been determined to be in substantial compliance with all applicable existing facilities and resource plans for SWTM by the Department of Water Resources. The Department of Water Resources will establish and maintain the standards and methodologies for these feasibility studies.
- c. A traffic analysis has been conducted that clearly identifies the impact of the adopted level of service within the Southwest Truckee Meadows planning area and the improvements likely to be required to maintain/achieve the adopted level of service. This finding may be waived by the Department of Public Works for projects that are determined to have minimal impacts. The Department of Public Works may request any information it deems necessary to make this determination.
- e. For residential land use intensifications, the potential increase in residential units will not exceed Washoe County's applicable policy growth level for the SWTM Area Plan, as established under Goal One.
- f. If the proposed intensification will result in a drop below the established policy level of service for transportation (as established by the Regional Transportation Commission and Washoe County) within the Southwest Truckee Meadows planning area, the necessary improvements required to maintain the established level of service are scheduled in either the Washoe County Capital Improvements Program or Regional Transportation Improvement Program within three years of approval of the intensification. For impacts to regional roads, the Washoe County Planning Commission, upon written request from the Regional Transportation Commission, may waive this finding.

- g. If roadways impacted by the proposed intensification are currently operating below adopted levels of service, the intensification will not require infrastructure improvements beyond those articulated in Washoe County and regional transportation plans AND the necessary improvements are scheduled in either the Washoe County Capital Improvements Program or Regional Transportation Improvement Program within three years of approval of the intensification.
- h. Proposed amendments shall complement the long-range plans of facilities providers for transportation, water resources, schools and parks as reflected in the policy growth level established in Policy 1.2.
- i. If the proposed intensification results in existing public school facilities exceeding design capacity and compromises the Washoe County School District's ability to implement the neighborhood school philosophy for elementary facilities, then there must be a current capital improvement plan or rezoning plan in place that would enable the District to absorb the additional enrollment. The Washoe County Planning Commission, upon request of the Washoe County School Board of Trustees, may waive this finding.
- j. Any existing development in the Southwest Truckee Meadows planning area, the South Valleys planning area, the Forest planning area, or the Southeast Truckee Meadows planning area which is subject to the conditions of a special use permit will not experience undue hardship in its ability to continue to comply with the conditions of the special use permit or otherwise to continue operation of its permitted activities.

Recommendation—Regulatory Zone Amendment

After a thorough analysis and review, it is recommended that the Washoe County Planning Commission deny the proposed Regulatory Zone Amendment, due to the inability to make the required findings. The following motion is provided for your consideration:

Recommended Motion—Regulatory Zone Amendment

I move that, after giving reasoned consideration to the information contained in the staff report and information received during the public hearing, the Planning Commission deny Regulatory Zone Amendment Case Number WRZA23-0009, being unable to make the required findings in accordance with Washoe County Code Section 110.821.15, including:

1. Consistency with Master Plan. The proposed amendment is in substantial compliance with the policies and action programs of the Master Plan and the Regulatory Zone Map.
2. Compatible Land Uses. The proposed amendment will provide for land uses compatible with (existing or planned) adjacent land uses, and will not adversely impact the public health, safety or welfare.
3. Response to Change Conditions; more desirable use. The proposed amendment responds to changed conditions or further studies that have occurred since the plan was adopted by the Board of County Commissioners, and the requested amendment represents a more desirable utilization of land.
4. Availability of Facilities. There are or are planned to be adequate transportation, recreation, utility, and other facilities to accommodate the uses and densities permitted by the proposed amendment.
5. No Adverse Effects. The proposed amendment will not adversely affect the implementation of the policies and action programs of the Washoe County Master Plan.
6. Desired Pattern of Growth. The proposed amendment will promote the desired pattern for the orderly physical growth of the County and guides development of the County based

on the projected population growth with the least amount of natural resource impairment and the efficient expenditure of funds for public services.

Should the Planning Commission disagree with the evaluation provided by staff, the following motions have been provided.

Alternative Motion—Master Plan Amendment

I move that, after giving reasoned consideration to the information contained in the staff report and information received during the public hearing, the Washoe County Planning Commission adopt the resolution contained at Attachment A of this staff report to amend the Master Plan as set forth in Master Plan Amendment Case Number WMPA23-0008 having made at least three of the five findings set forth in Washoe County Code Section 110.820.15(d)(1)-(5) and having made the required findings in accordance with Southwest Truckee Meadows Area Plan Policy SW.20.1 and SW.20.3. I further move to certify the resolution and the proposed Master Plan Amendments in WMPA23-0008 as set forth in this staff report for submission to the Washoe County Board of County Commissioners and authorize the chair to sign the resolution on behalf of the Planning Commission.

1. Consistency with Master Plan. The proposed amendment is in substantial compliance with the policies and action programs of the Master Plan.
2. Compatible Land Uses. The proposed amendment will provide for land uses compatible with (existing or planned) adjacent land uses, and will not adversely impact the public health, safety or welfare.
3. Response to Change Conditions. The proposed amendment responds to changed conditions or further studies that have occurred since the plan was adopted by the Board of County Commissioners, and the requested amendment represents a more desirable utilization of land.
4. Availability of Facilities. There are or are planned to be adequate transportation, recreation, utility, and other facilities to accommodate the uses and densities permitted by the proposed Master Plan designation.
5. Desired Pattern of Growth. The proposed amendment will promote the desired pattern for the orderly physical growth of the County and guides development of the County based on the projected population growth with the least amount of natural resource impairment and the efficient expenditure of funds for public services.

The following findings are required to be made per Area Plan policy SW.20.1:

- a. The amendment will further implement and preserve the Vision and Character Statement.
- b. The amendment conforms to all applicable policies of the SWTM Area Plan and the Washoe County Master Plan, and the Regional Water Management Plan.
- c. The amendment will not conflict with the public's health, safety or welfare.

The following findings are required to be made per Area Plan policy SW.20.3:

- a. The impacts of the amendment are within commonly accepted thresholds of sustainable resource management and the county's ability to manage the conservation of the area's character will not be compromised.
- b. A feasibility study has been conducted, commissioned and paid for by the applicant, relative to municipal water, sewer and storm water that clearly identifies the improvements likely to be required to support the intensification, and those improvements have been determined to be in substantial compliance with all applicable existing facilities and

resource plans for SWTM by the Department of Water Resources. The Department of Water Resources will establish and maintain the standards and methodologies for these feasibility studies.

- c. A traffic analysis has been conducted that clearly identifies the impact of the adopted level of service within the Southwest Truckee Meadows planning area and the improvements likely to be required to maintain/achieve the adopted level of service. This finding may be waived by the Department of Public Works for projects that are determined to have minimal impacts. The Department of Public Works may request any information it deems necessary to make this determination.
- e. For residential land use intensifications, the potential increase in residential units will not exceed Washoe County's applicable policy growth level for the SWTM Area Plan, as established under Goal One.
- f. If the proposed intensification will result in a drop below the established policy level of service for transportation (as established by the Regional Transportation Commission and Washoe County) within the Southwest Truckee Meadows planning area, the necessary improvements required to maintain the established level of service are scheduled in either the Washoe County Capital Improvements Program or Regional Transportation Improvement Program within three years of approval of the intensification. For impacts to regional roads, the Washoe County Planning Commission, upon written request from the Regional Transportation Commission, may waive this finding.
- g. If roadways impacted by the proposed intensification are currently operating below adopted levels of service, the intensification will not require infrastructure improvements beyond those articulated in Washoe County and regional transportation plans AND the necessary improvements are scheduled in either the Washoe County Capital Improvements Program or Regional Transportation Improvement Program within three years of approval of the intensification.
- h. Proposed amendments shall complement the long-range plans of facilities providers for transportation, water resources, schools and parks as reflected in the policy growth level established in Policy 1.2.
- i. If the proposed intensification results in existing public school facilities exceeding design capacity and compromises the Washoe County School District's ability to implement the neighborhood school philosophy for elementary facilities, then there must be a current capital improvement plan or rezoning plan in place that would enable the District to absorb the additional enrollment. The Washoe County Planning Commission, upon request of the Washoe County School Board of Trustees, may waive this finding.
- j. Any existing development in the Southwest Truckee Meadows planning area, the South Valleys planning area, the Forest planning area, or the Southeast Truckee Meadows planning area which is subject to the conditions of a special use permit will not experience undue hardship in its ability to continue to comply with the conditions of the special use permit or otherwise to continue operation of its permitted activities.

Alternative Motion—Regulatory Zone Amendment

I move that, after giving reasoned consideration to the information contained in the staff report and information received during the public hearing, the Planning Commission adopt the resolution included as Exhibit B, recommending adoption of Regulatory Zone Amendment Case Number WRZA23-0009, having made all of the following findings in accordance with Washoe County Code Section 110.821.15(d). I further move to certify the resolution and the proposed Regulatory Zone Amendment in WRZA23-0009 as set forth in this staff report for submission to the Washoe County Board of Commissioners and authorize the chair to sign the resolution on behalf of the Washoe County Planning Commission.

1. Consistency with Master Plan. The proposed amendment is in substantial compliance with the policies and action programs of the Master Plan and the Regulatory Zone Map.
2. Compatible Land Uses. The proposed amendment will provide for land uses compatible with (existing or planned) adjacent land uses, and will not adversely impact the public health, safety or welfare.
3. Response to Change Conditions; more desirable use. The proposed amendment responds to changed conditions or further studies that have occurred since the plan was adopted by the Board of County Commissioners, and the requested amendment represents a more desirable utilization of land.
4. Availability of Facilities. There are or are planned to be adequate transportation, recreation, utility, and other facilities to accommodate the uses and densities permitted by the proposed amendment.
5. No Adverse Effects. The proposed amendment will not adversely affect the implementation of the policies and action programs of the Washoe County Master Plan.
6. Desired Pattern of Growth. The proposed amendment will promote the desired pattern for the orderly physical growth of the County and guides development of the County based on the projected population growth with the least amount of natural resource impairment and the efficient expenditure of funds for public services.

Appeal Process

Planning Commission action will be effective 10 calendar days after the written decision is filed with the Secretary to the Planning Commission and mailed to the original applicant, unless the action is appealed to the Washoe County Board of County Commissioners, in which case the outcome of the appeal shall be determined by the Washoe County Board of County Commissioners. Any appeal must be filed in writing with the Planning and Building Division within 10 calendar days from the date the written decision is filed with the Secretary to the Planning Commission and mailed to the original applicant.

Applicant/Owner: David Thompson, davethom43@gmail.com

Representatives: John Krmpotic, John@klsdesigngroup.com



RESOLUTION OF THE WASHOE COUNTY PLANNING COMMISSION

ADOPTING AMENDMENTS TO THE WASHOE COUNTY MASTER PLAN, SOUTHWEST TRUCKEE MEADOWS AREA PLAN, MASTER PLAN MAP (WMPA23-0008) TO REDESIGNATE 8.36 ACRES OF TWO PACELS TOTALLING 81.83 ACRES FROM RURAL (R) TO SUBURBAN RESIDENTIAL (SR), AND RECOMMENDING ADOPTION OF THESE AMENDMENTS TO THE BOARD OF COUNTY COMMISSIONERS (PORTIONS OF APN 041-650-04 AND 041-650-05)

Resolution 24-06

Whereas, Master Plan Amendment Case Number WMPA23-0008 came before the Washoe County Planning Commission for a duly noticed public hearing on January 2, 2024; and

Whereas, the Washoe County Planning Commission heard public comment and input from both staff and the public regarding the proposed master plan amendments; and

Whereas, the Washoe County Planning Commission gave reasoned consideration to the information it received regarding the proposed master plan amendments;

Whereas, the Washoe County Planning Commission has made the following findings necessary to support adoption of the proposed Master Plan Amendment Case Number WMPA23-0008, as set forth in NRS Chapter 278 and Washoe County Code Chapter 110 (Development Code), Article 820:

Washoe County Code Section 110.820.15 (d) Master Plan Amendment Findings

1. Consistency with Master Plan. The proposed amendment is in substantial compliance with the policies and action programs of the Master Plan.
2. Compatible Land Uses. The proposed amendment will provide for land uses compatible with (existing or planned) adjacent land uses, and will not adversely impact the public health, safety or welfare.
3. Response to Change Conditions. The proposed amendment responds to changed conditions or further studies that have occurred since the plan was adopted by the Board of County Commissioners, and the requested amendment represents a more desirable utilization of land.
4. Availability of Facilities. There are or are planned to be adequate transportation, recreation, utility, and other facilities to accommodate the uses and densities permitted by the proposed Master Plan designation.

5. Desired Pattern of Growth. The proposed amendment will promote the desired pattern for the orderly physical growth of the County and guides development of the County based on the projected population growth with the least amount of natural resource impairment and the efficient expenditure of funds for public services.

Southwest Truckee Meadows Area Plan Required Findings

Policy SW.20.1:

- a. The amendment will further implement and preserve the Vision and Character Statement.
- b. The amendment conforms to all applicable policies of the SWTM Area Plan and the Washoe County Master Plan, and the Regional Water Management Plan.
- c. The amendment will not conflict with the public's health, safety or welfare.

Policy SW.20.3:

- a. The impacts of the amendment are within commonly accepted thresholds of sustainable resource management and the county's ability to manage the conservation of the area's character will not be compromised.
- b. A feasibility study has been conducted, commissioned and paid for by the applicant, relative to municipal water, sewer and storm water that clearly identifies the improvements likely to be required to support the intensification, and those improvements have been determined to be in substantial compliance with all applicable existing facilities and resource plans for SWTM by the Department of Water Resources. The Department of Water Resources will establish and maintain the standards and methodologies for these feasibility studies.
- c. A traffic analysis has been conducted that clearly identifies the impact to the adopted level of service within the Southwest Truckee Meadows planning area and the improvements likely to be required to maintain/achieve the adopted level of service. This finding may be waived by the Department of Public Works for projects that are determined to have minimal impacts. The Department of Public Works may request any information it deems necessary to make this determination.
- e. For residential land use intensifications, the potential increase in residential units will not exceed Washoe County's applicable policy growth level for the SWTM Area Plan, as established under Goal One.
- h. Proposed amendments shall complement the long range plans of facilities providers for transportation, water resources, schools and parks as reflected in the policy growth level established in Policy 1.2.
- j. Any existing development in the Southwest Truckee Meadows planning area, the South Valleys planning area, the Forest planning area, or the Southeast Truckee Meadows planning area which is subject to the conditions of a special use permit will not experience undue hardship in its ability to continue to comply with the conditions of the special use permit or otherwise to continue operation of its permitted activities.

Now, therefore, be it resolved that pursuant to NRS 278.210(3):

- (1) Subject to approval by the Washoe County Board of County Commissioners, approval of a regional plan amendment to the Truckee Meadows Regional Plan, and a finding of conformance with the Truckee Meadows Regional Plan, the Washoe County Planning Commission does hereby adopt Master Plan Amendment Case Number WMPA23-0008, comprised of the map as included at Exhibit A to this resolution, descriptive matter and other matter intended to constitute the amendments as submitted at the public hearing noted above; and

(2) To the extent allowed by law, this approval is subject to the conditions adopted by the Planning Commission at the public hearing noted above.

A certified copy of this resolution shall be submitted to the Board of County Commissioners and any appropriate reviewing agencies in accordance with NRS 278.220.

ADOPTED on January 2, 2024

WASHOE COUNTY PLANNING COMMISSION

ATTEST:

Trevor Lloyd, Secretary

Rob Pierce, Chair

Attachment: Exhibit A – Southwest Truckee Meadows Master Plan Map

Exhibit A, WMPA23-0008

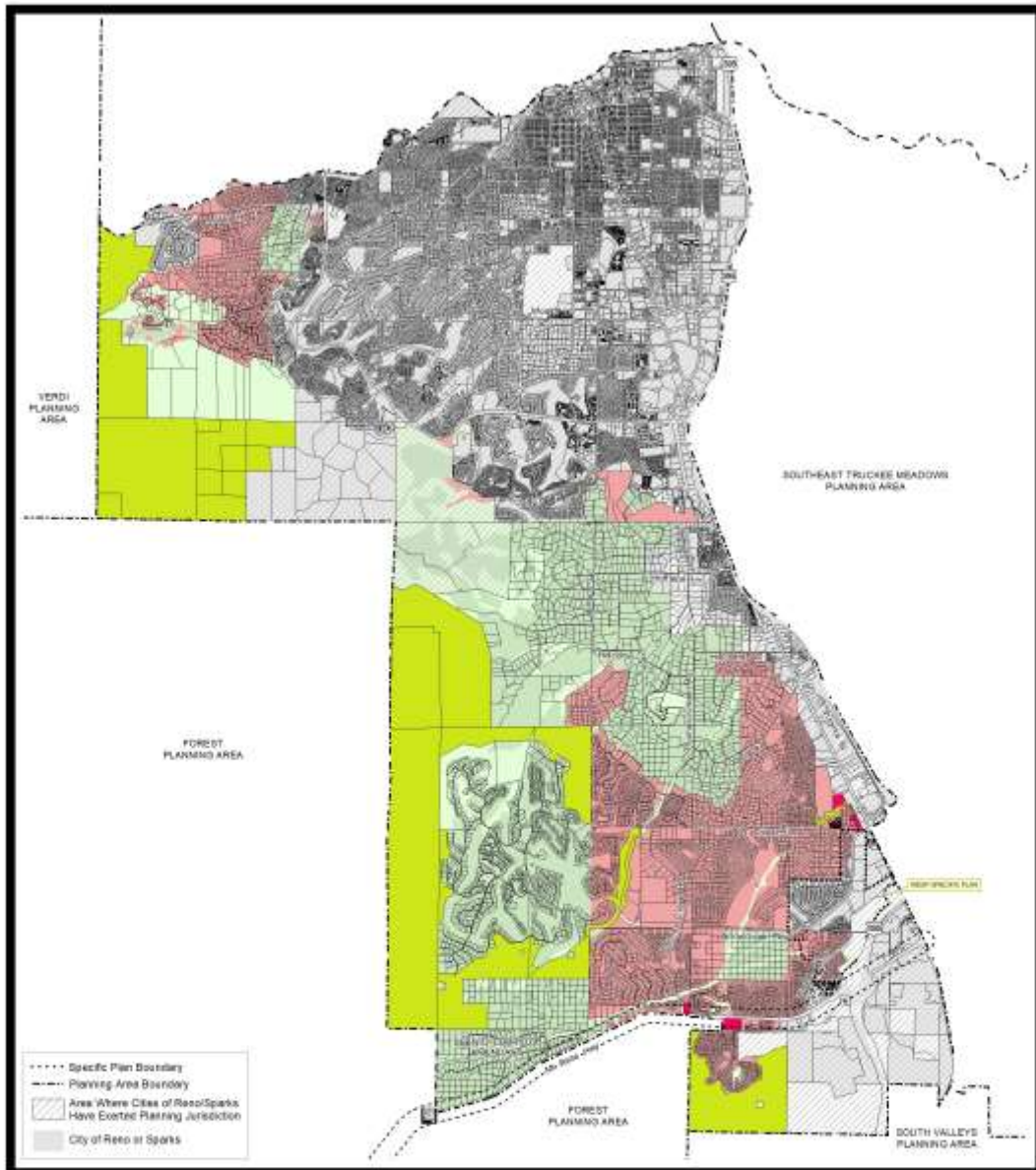



RESOLUTION OF THE WASHOE COUNTY PLANNING COMMISSION

RECOMMENDING ADOPTION OF REGULATORY ZONE AMENDMENT CASE NUMBER WRZA23-0009 WHICH AMENDS THE SOUTHWEST TRUCKEE MEADOWS REGULATORY ZONE MAP TO REDESIGNATE 8.36 ACRES OF TWO PARCELS TOTALLING 81.83 ACRES FROM GENERAL RURAL (GR) TO LOW DENSITY SUBURBAN (LDS) (PORTIONS OF APN 041-650-04 AND 041-650-05)

Resolution 24-07

Whereas Regulatory Zone Amendment Case Number WRZA23-0009, came before the Washoe County Planning Commission for a duly noticed public hearing on January 2, 2024; and

Whereas the Washoe County Planning Commission heard public comment and input from staff regarding the proposed regulatory zone amendment; and

Whereas, the Washoe County Planning Commission has given reasoned consideration to the information it has received regarding the proposed regulatory zone amendment; and

Whereas, the Washoe County Planning Commission has made the findings necessary to support adoption of this proposed regulatory zone amendment as set forth in NRS Chapter 278 and Washoe County Code Chapter 110, Article 821, Amendment of Regulatory Zone;

Whereas the proposed regulatory zone amendment shall be recommended for adoption pending adoption of the accompanying proposed Master Plan Amendment (WMPA23-0008) by the Washoe County Board of County Commissioners and a finding of conformance by the Truckee Meadows Regional Planning Commission; and

Whereas, pursuant to Washoe County Code Section 110.821.15(d), in making this recommendation, the Washoe County Planning Commission finds that this proposed regulatory zone amendment meets the following requirements:

1. Consistency with Master Plan. The proposed amendment is in substantial compliance with the policies and action programs of the Master Plan;
2. Compatible Land Uses. The proposed amendment will provide for land uses compatible with (existing or planned) adjacent land uses, and will not adversely impact the public health, safety or welfare;
3. Response to Change Conditions; more desirable use. The proposed amendment responds to changed conditions or further studies that have occurred since the plan was adopted by the Board of County Commissioners, and the requested amendment represents a more desirable utilization of land;

4. Availability of Facilities. There are or are planned to be adequate transportation, recreation, utility, and other facilities to accommodate the uses and densities permitted by the proposed amendment;
5. No Adverse Effects. The proposed amendment will not adversely affect the implementation of the policies and action programs of the Washoe County Master Plan,
6. Desired Pattern of Growth. The proposed amendment will promote the desired pattern for the orderly physical growth of the County and guides development of the County based on the projected population growth with the least amount of natural resource impairment and the efficient expenditure of funds for public services; and

Now, therefore, be it resolved that the Washoe County Planning Commission does hereby recommend adoption of Regulatory Zone Amendment Case Number WRZA23-0009 and the amended Southwest Truckee Meadows Regulatory Zone Map included as Exhibit A to this resolution to the Washoe County Board of County Commissioners.

ADOPTED on January 2, 2024.

WASHOE COUNTY PLANNING COMMISSION

ATTEST:

Trevor Lloyd, Secretary

Rob Pierce, Chair

Attachment: Exhibit A – Southwest Truckee Meadows Area Plan Regulatory Zone Map

Exhibit A – WRZA23-0009

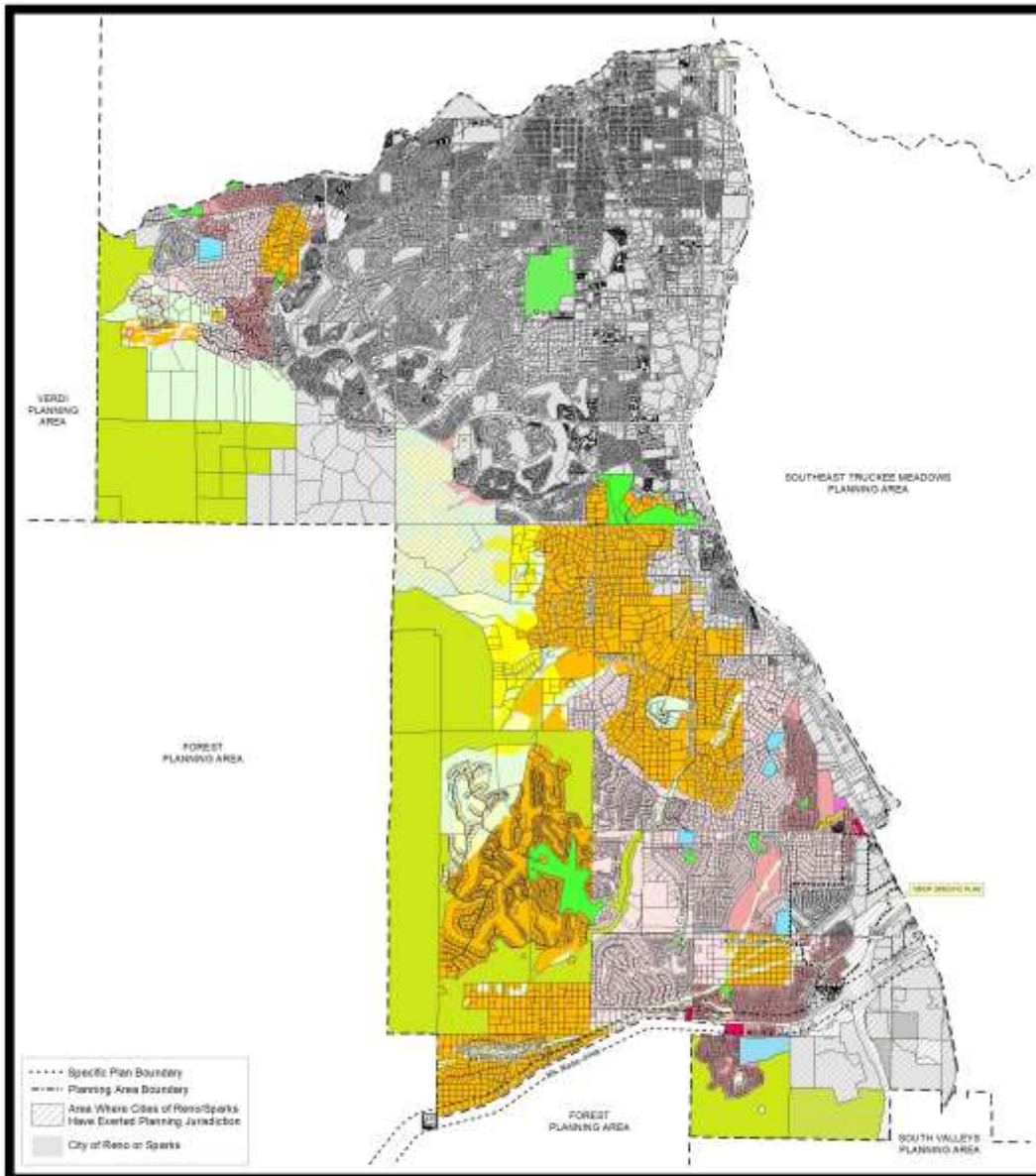

SOUTHWEST REGULATORY ZONE MAP

| | | |
|--|---|---|
| <ul style="list-style-type: none"> LOW DENSITY RURAL MEDIUM DENSITY RURAL HIGH DENSITY RURAL LOW DENSITY SUBURBAN LOW DENSITY SUBURBAN 2 MEDIUM DENSITY SUBURBAN MEDIUM DENSITY SUBURBAN 4 | <ul style="list-style-type: none"> HIGH DENSITY SUBURBAN LOW DENSITY URBAN MEDIUM DENSITY URBAN HIGH DENSITY URBAN GENERAL COMMERCIAL NEIGHBORHOOD COMMERCIAL OFFICE TOURIST COMMERCIAL | <ul style="list-style-type: none"> INDUSTRIAL PUBLIC AND SEMI-PUBLIC FACILITIES PARKS AND RECREATION OPEN SPACE GENERAL RURAL GENERAL RURAL AGRICULTURAL DRY LAKE/ WATER BODY |
|--|---|---|

Planning and Building Division

NOTE: THE SCALE AND COMPLETENESS OF ALL INFORMATION PROVIDED HEREON ARE APPROXIMATE AND NOT GUARANTEED. THERE IS NO LIABILITY FOR ERRORS OR OMISSIONS. THIS MAP IS NOT TO BE USED FOR ANY PURPOSE OTHER THAN THAT FOR WHICH IT WAS DESIGNED AND FOR WHICH IT WAS INTENDED.

CAUTION: THIS DOCUMENT HAS BEEN REVIEWED AND APPROVED AS AN ACCURATE REPRESENTATION OF THE ADOPTED REGULATORY ZONE MAP OF WASHOE COUNTY, NEVADA, BY THE WASHOE COUNTY PLANNING AND BUILDING DIVISION.

DATE: 08/11/2021

Community Services Department

WASHOE COUNTY NEVADA

1001 E. North St.
Reno, Nevada 89512 (775) 328-3600

Public Notice

Washoe County Code requires that public notification for a special use permit must be mailed to a minimum of 30 separate property owners within a minimum 750-foot radius of the subject property a minimum of 10 days prior to the public hearing date. A notice setting forth the time, place, purpose of hearing, a description of the request and the land involved was sent within a 1,100-foot radius of the subject property. A total of 34 separate property owners were noticed a minimum of 10 days prior to the public hearing date.

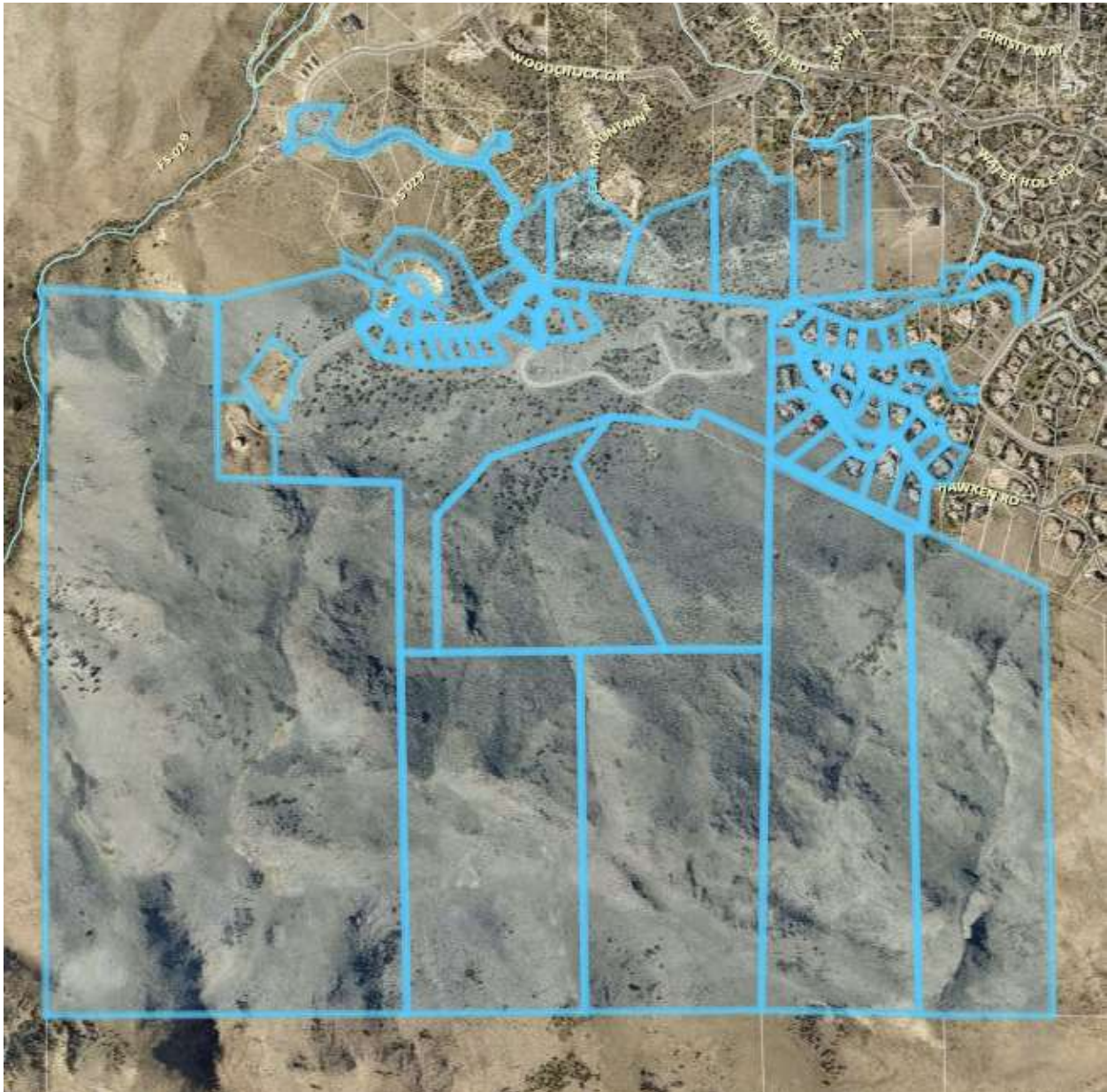

Public Notice Map

Case Number WMPA23-0008/WRZA23-0009

Date: September 28, 2023

To: Kat Oakley, Planner

From: Janelle K. Thomas, P.E., C.F.M., Senior Licensed Engineer
Robert Wimer, P.E., Licensed Engineer

Re: Master Plan Amendment WMPA23-0008; Regulatory Zone Amendment WRZA23-0006
APN 041-650-04 & 041-650-05

GENERAL PROJECT DISCUSSION

Washoe County Engineering and Capital Project staff have reviewed the above referenced application. The application is for the master plan amendment and regulatory zone amendment to:

- (1) Approve an amendment to the Southwest Area Plan, a component of the Washoe County Master Plan, to redesignate 9.48 acres of two parcels totaling 81.83 acres from Rural (R) to Suburban Residential (SR); and,
- (2) Recommend adoption of an amendment to the Southwest Regulatory zone Map, to redesignate 9.48 acres of the same parcels from General Rural (GR) to Low Density Suburban (LDS); and
- (3) If approved, authorize the chair to sign a resolution to this effect.

The Engineering and Capital Projects Division recommends denial with the following comments which supplement the applicable County Code and are based upon our review of the application prepared by the owner.

For questions related to sections below, please see the staff's name provided.

GENERAL COMMENTS

Contact Information: Robert Wimer, P.E. (775) 328-2059

1. The proposed street exceeds the maximum allowable slope for a residential street in Washoe County Development Code section 110.436.30.
2. The proposed lots do not offer the ability to meet the maximum driveway slopes allowed in Washoe County Development Code section 110.436.30.
3. The proposed lots do not offer a buildable area for development of a construction pad for a residence.

Oakley, Katherine

From: Lemon, Brittany
Sent: Tuesday, September 19, 2023 11:10 AM
To: Oakley, Katherine
Cc: Way, Dale
Subject: WMPA23-0008 and Regulatory Zone Amendment WRZA23-0009 (Thomson Family Trust) Conditions of Approval

Hi Kat,

“This project shall meet and comply with all requirements of currently adopted TMFPD fire codes, ordinances, and standards at the time of construction to include infrastructure for fire apparatus access roads and water supply.”
<https://tmfpd.us/fire-code/>.

This parcel is located in a high fire hazard severity area and any development on the parcel is required to comply with the adopted International Wildland Urban Interface Code.

Thank you,

Brittany Lemon

Fire Captain - Fire Prevention | Truckee Meadows Fire & Rescue

blemon@tmfpd.us | Office: 775.326.6079 | Cell: 775.379.0584

3663 Barron Way, Reno, NV 89511



“Committed to excellence, service, and the protection of life and property in our community”

Oakley, Katherine

From: Albarran, Adriana
Sent: Thursday, September 21, 2023 9:40 AM
To: Oakley, Katherine; Stark, Katherine; Bronczyk, Christopher
Subject: FW: September Agency Review Memo II

For your cases.

Regards,



Adriana Albarran

Office Support Specialist, Planning & Building Division | Community Services Department

aalbarran@washoecounty.gov | Direct Line: 775.328.2721

My working hours: Monday-Friday 8:30am to 5:00pm

Visit us first online: www.washoecounty.gov/csd

Planning Division: 775.328.6100 | Planning@washoecounty.gov

CSD Office Hours: Monday-Friday 8:00am to 4:00pm

1001 East Ninth Street, Reno, NV 89512



Have some kudos to share about a Community Services Department employee or experience?

[Submit a Nomination](#)

From: Katie Andrlle <kmandrle@ndow.org>
Sent: Wednesday, September 20, 2023 2:39 PM
To: Albarran, Adriana <AAlbarran@washoecounty.gov>
Subject: RE: September Agency Review Memo II

[NOTICE: This message originated outside of Washoe County -- **DO NOT CLICK** on links or open attachments unless you are sure the content is safe.]

Hi Adriana,

I don't have any comments. Thanks!

From: Albarran, Adriana <AAlbarran@washoecounty.gov>
Sent: Monday, September 18, 2023 9:00 AM
To: Katie Andrlle <kmandrle@ndow.org>
Subject: September Agency Review Memo II

WARNING - This email originated from outside the State of Nevada. Exercise caution when opening attachments or clicking links, especially from unknown senders.

Hello,

Please find the attached **Agency Review Memo II** with cases received in **September** by Washoe County Community Services Department, Planning and Building Division.

You've been asked to review the applications for the items indicated below. The item descriptions and links to the applications are provided in the memo.

#1 – #10 – Agency Comments and Conditions Due – September 25, 2023

#11 – #12 – Agency Comments and Conditions Due – October 2, 2023

Please remember to send any agency review responses/comments directly to the Planner for the case, rather than replying to me.

~~~~~

- Item 4 - WSUP23-0016
- Item 8 – WSUP23-0030
- Item 9 – WSUP23-0031
- Item 11 – WTPM23-0011

Regards,



**Adriana Albarran**

Office Support Specialist, Planning & Building Division | Community Services Department

[aalbarran@washoecounty.gov](mailto:aalbarran@washoecounty.gov) | Direct Line: 775.328.2721

**My working hours: Monday-Friday 8:30am to 5:00pm**

Visit us first online: [www.washoecounty.gov/csd](http://www.washoecounty.gov/csd)

Planning Division: 775.328.6100 | [Planning@washoecounty.gov](mailto:Planning@washoecounty.gov)

CSD Office Hours: Monday-Friday 8:00am to 4:00pm

1001 East Ninth Street, Reno, NV 89512



Have some kudos to share about a Community Services Department employee or experience?

[Submit a Nomination](#)

## Oakley, Katherine

---

**From:** Evans, Timothy  
**Sent:** Thursday, October 5, 2023 8:02 AM  
**To:** Sullivan, Mark (NV Energy)  
**Cc:** Oakley, Katherine  
**Subject:** RE: [INTERNET] September Agency Review Memo I

Hi Mark,

Thanks for the information. Kat Oakley is processing that case. I have cc'd her on this email.

Thanks,



**Tim Evans**  
Planner, Planning & Building Division | Community Services Department  
CSD Main Phone: 775-328-3600 Direct Line: 775-328-2314  
Visit us first online: [www.washoecounty.gov/csd](http://www.washoecounty.gov/csd)

---

**From:** Sullivan, Mark (NV Energy) <Mark.Sullivan@nvenergy.com>  
**Sent:** Thursday, October 5, 2023 7:31 AM  
**To:** Evans, Timothy <TEvans@washoecounty.gov>  
**Subject:** RE: [INTERNET] September Agency Review Memo I

[NOTICE: This message originated outside of Washoe County -- DO NOT CLICK on links or open attachments unless you are sure the content is safe.]

Tim,

Yes Thompson Family Trust master plan is the one I was referring to can you forward the info to them for me or provide their contact info?

Thanks,

Mark Sullivan  
Land Use Advisor  
NV Energy  
(775) 420-7722  
[mark.sullivan@nvenergy.com](mailto:mark.sullivan@nvenergy.com)

---

**From:** Evans, Timothy <TEvans@washoecounty.gov>  
**Sent:** Wednesday, October 4, 2023 5:08 PM  
**To:** Sullivan, Mark (NV Energy) <Mark.Sullivan@nvenergy.com>  
**Subject:** RE: [INTERNET] September Agency Review Memo I

You don't often get email from [tevens@washoecounty.gov](mailto:tevens@washoecounty.gov). [Learn why this is important](#)

**THIS MESSAGE IS FROM AN EXTERNAL SENDER.**

Look closely at the **SENDER** address. Do not open **ATTACHMENTS** unless expected. Check for **INDICATORS** of phishing. Hover over **LINKS** before clicking. [Learn to spot a phishing message](#)

Hi Mark,

Thanks for the comment. Which project is your comment in relation to? The project that involves the Thompson Family Trust is a master plan amendment and it's being processed by another planner. If you could confirm which project you are referring to I'd really appreciate it.

Thanks,



**Tim Evans**

**Planner, Planning & Building Division | Community Services Department**

CSD Main Phone: 775-328-3600 Direct Line: 775-328-2314

Visit us first online: [www.washoecounty.gov/csd](http://www.washoecounty.gov/csd)

---

**From:** Sullivan, Mark (NV Energy) <[Mark.Sullivan@nvenergy.com](mailto:Mark.Sullivan@nvenergy.com)>

**Sent:** Wednesday, October 4, 2023 2:28 PM

**To:** Evans, Timothy <[TEvens@washoecounty.gov](mailto:TEvens@washoecounty.gov)>

**Subject:** FW: [INTERNET] September Agency Review Memo I

[**NOTICE:** This message originated outside of Washoe County -- **DO NOT CLICK** on **links** or open **attachments** unless you are sure the content is safe.]

Hi Tim,

I have been out of the office for two weeks and just got the comment back that the Thompson Family Trust has lot #18 and 19 encroaching into our ROW per their plans. We will need to see the improvement plans to make sure their grading doesn't impact our lines. There are no other comments for the other projects.

---

**From:** Roman, Brandon <[BRoman@washoecounty.gov](mailto:BRoman@washoecounty.gov)>

**Sent:** Friday, September 15, 2023 12:52:38 PM

**To:** Sullivan, Mark (NV Energy) <[marksullivan@nvenergy.com](mailto:marksullivan@nvenergy.com)>

**Subject:** [INTERNET] September Agency Review Memo I

**THIS MESSAGE IS FROM AN EXTERNAL SENDER.**

Look closely at the **SENDER** address. Do not open **ATTACHMENTS** unless expected. Check for **INDICATORS** of phishing. Hover over **LINKS** before clicking. [Learn to spot a phishing message](#)

Good morning,

Please remember to send agency review responses/comments directly to the Planner for the case, rather than replying to me.

Please find the attached **Agency Review Memo I** with cases received in **September** by Washoe County Community Services Department, Planning and Building Division. You've been asked to review the application

for **Item #1**. The item description and link to the application are provided in the memo. **Comments are due by September 28, 2023.**

Sincerely,



**Brandon Roman**  
**Office Support Specialist, Planning & Building Division | Community Services Department**

[broman@washoecounty.gov](mailto:broman@washoecounty.gov) | Direct Line: 775.328.3606

My working hours: Monday-Friday 7:00am to 3:30pm

Visit us first online: [www.washoecounty.gov/csd](http://www.washoecounty.gov/csd)

Planning Division: 775.328.6100 | [Planning@washoecounty.gov](mailto:Planning@washoecounty.gov)

CSD Office Hours: Monday-Friday 8:00am to 4:00pm

1001 East Ninth Street, Reno, NV 89512



Have some kudos to share about a Community Services Department employee or experience?

[Submit a Nomination](#)

---

*This email, including attachments, may contain highly sensitive, confidential, proprietary or valuable information. It is intended only for the designated recipient(s) named above. Any unauthorized use, reproduction, forwarding or distribution of this transmission, including attachments, is prohibited. If you have received this communication in error, please immediately notify the sender and permanently delete any record of this transmission.*

## Oakley, Katherine

---

**From:** Pekar, Faye-Marie L.  
**Sent:** Tuesday, October 10, 2023 10:50 AM  
**To:** Oakley, Katherine  
**Subject:** WMPA23-0008 and WRZA23-0009 (Thompson Family Trust)

Hi Kat,

I have reviewed WMPA23-0008 and WRZA23-0009 (Thompson Family Trust) on behalf of parks and do not have any comments.

Thank you,



**Faye-Marie L. Pekar, MPA**

**Park Planner, Planning & Building Division | Community Services Department**

[fpekar@washoecounty.gov](mailto:fpekar@washoecounty.gov) |

Visit us first online: [www.washoecounty.gov/csd](http://www.washoecounty.gov/csd)

Planning Division: 775.328.6100 | [Planning@washoecounty.gov](mailto:Planning@washoecounty.gov)

CSD Office Hours: Monday-Friday 8:00am to 4:00pm

1001 East Ninth Street, Reno, NV 89512



Have some kudos to share about a Community Services Department employee or experience? Submit a nomination for a Washoe Star by clicking this link: **[WASHOE STAR](#)**

## Oakley, Katherine

---

**From:** Steve Shell <sshell@water.nv.gov>  
**Sent:** Tuesday, September 19, 2023 1:35 PM  
**To:** Oakley, Katherine  
**Subject:** WMPA23-0008 & WRZA23-0009

[NOTICE: This message originated outside of Washoe County -- **DO NOT CLICK** on links or open **attachments** unless you are sure the content is safe.]

The subject property lies within the Truckee Meadows Water Authority service area.

Municipal water service is subject to Truckee Meadows Water Authority rules and regulations and approval by the Office of the State Engineer regarding water quantity and availability.

A Will Serve from Truckee Meadows Water Authority and a mylar map of the proposed project must be presented to the State Engineer for approval and signed through his office prior to development.

As of June 1, 2021, the Office of the State Engineer is open to the public. Please call 684-2800 upon arrival and a representative will come down to escort you to our office.

### Steve Shell

Water Rights Specialist II  
Department of Conservation and Natural Resources  
Nevada Division of Water Resources  
901 S. Stewart St., Suite 2002  
Carson City, NV 89701  
[sshell@water.nv.gov](mailto:sshell@water.nv.gov)  
(O) 775-684-2836 | (F) 775-684-2811



NEVADA DIVISION  
OF WATER RESOURCES



## INITIAL REVIEW MEMORANDUM

TO: Kat Oakley, Washoe County

FROM: Chris Tolley, TMRPA

DATE: December 11, 2023

**SUBJECT: REVISED: TMRPA initial review of Washoe County case WMPA23-0008  
(Thompson Family Trust)**

---

This memorandum provides the revised Truckee Meadows Regional Planning Agency's (TMRPA) initial review comments regarding the subject case (WMPA23-0008), as stated in the 2019 Truckee Meadows Regional Plan (Policy RC 5).

The following constitutes an initial review based on the limited information available at the time of this memorandum. TMRPA recognizes that the proposal may change through the jurisdictional review of the case. Should the case be approved through Washoe County, the proposal will need to be formally submitted to TMRPA for a review of conformance with the 2019 Truckee Meadows Regional Plan in its entirety.

The request has been revised to reduce the area proposed to be redesignated as the Suburban Residential (SR) land use from 9.48 acres to 8.36 acres, so this memorandum reflects the revised acreages.

The request, as identified by Washoe County, is the following:

(1) **Approve an amendment to the Southwest Area Plan, a component of the Washoe County Master Plan, to redesignate 8.36 acres of two parcels totaling 81.83 acres from Rural (R) to Suburban Residential (SR); and,**

(2) Recommend adoption of an amendment to the Southwest Regulatory zone Map, to redesignate 8.36 acres of the same parcels from General Rural (GR) to Low Density Suburban (LDS)

[TMRPA notes: **bolded text** identifies the portion of the request that is subject to review under the Regional Plan]

### **Potential conformance issues**

#### *Regional Land Designation Amendment*

The subject site is located within the Tier 3 Regional Land Designation, and per Policy RF 3 – *Density Requirements and Nonresidential Standards*, the maximum density for lands within this tier is the currently existing maximum. For the subject site, the maximum density is established by the existing Rural land use.



In order to intensify the subject site, a Regional Plan amendment to change the Regional Land Designation to a higher priority Tier (e.g., from Tier 3 to Tier 2) is required. Please review Regional Plan Policy *RF 5* for additional information, including the specific review criteria.

For reference, the Tier 2 Regional Land Designation is located approximately 0.7 miles east of the subject site.

Any request amendment to the Regional Plan amendment should be sponsored by the Washoe County Commission per Nevada Revised States (NRS) section 278.0272(7) and the Regional Planning Governing Board's Regulations on Procedure section II.2. Please contact Regional Planning staff for any assistance with this specific process.

#### *Public Facilities and Services*

One of the primary review criteria for requests to amend the existing Regional Land Designation, and also for a request to amend a master plan, is the availability of public facilities and services. This component of regional analysis is detailed in 2019 Regional Plan Policy *PF 1 – List of Facilities and Service Standards*, which lists the five domains that are addressed by the Regional Plan. These domains include water, wastewater, flood control/stormwater drainage management, transportation and schools, and the applicable standard(s) for each is noted in Table 3.2.

After reviewing the materials submitted to Washoe County, it appears that any future development of the subject site is based on the assumption that public facilities (water, wastewater, stormwater drainage management, and possibly including road facilities) will be extended to within close proximity of the subject site by the Ridges at Hunter Creek development located immediately north. This scenario does not necessarily satisfy the requirements of *PF 1*. Additionally, it is not clear whether the infrastructure planning (for the domains) that has occurred as part of the Ridges at Hunter Creek development could accommodate the proposal.

#### *Development Constraints Analysis*

The subject site contains a large amount of Development Constraints Area (DCA) for natural slopes over 30%. Policy *NR 3 – Development Constraints Area* identifies that the "DCA overlay takes precedence over otherwise applicable policies describing the desired density and intensity of development within the [Truckee Meadows Service Area] and [Rural Area]." This proposal will be reviewed against the entire policy, and as it relates to the proposed Regional Land Designation/Washoe County Master Plan amendment.

#### **Related Regional Plan policies**

Please review the list of policies provided in this section, as the requirements of each should be addressed (or connected to the implementing policy in the Washoe County Master Plan) in the analysis presented for the subject case:

PG 4 – Affordable Housing Strategies

RF 3 – Density Requirements and Nonresidential Standards

RF 5 – Regional Land Designation Amendments

RF 11 – Compatibility Factors

PF 1 – List of Facilities and Service Standards

NR 3 – Development Constraints Area

NR 5 – Natural Slopes greater than 15% and less than or equal to 30%

NR 8 – Wildland/Urban Interface

RC 9 – Conformance Review Findings

RC 10 – Regional Plan Amendment Findings

**Data and information related to Regional Plan implementation**

Regional Land Designation: Tier 3

Development Constraints Area: natural slopes over 30%

Regional Utility Corridors: located on the northern boundary of the subject site

**Request for comment from other local government and/or affected entities**

None at this time

**Other information for review**

None at this time

Please do not hesitate to contact TMRPA staff at 775-321-8385 if you have any questions or comments on this initial review memorandum. For more information, you can access the [2019 Truckee Meadows Regional Plan](#) and the [Regional Data Viewer](#) at [www.tmrpa.org](http://www.tmrpa.org).



Washoe-Storey Conservation District

Bret Tyler Chairmen  
Jim Shaffer Treasurer  
Cathy Canfield Storey app  
Jean Herman Washoe app

1365 Corporate Blvd.  
Reno NV 89502  
775 857-8500 ext. 131  
nevadaconservation.com

November 28, 2023

Washoe County Community Services Department

C/O Kat Oakley, Planner

1001 E Ninth Street, Bldg. A

Reno, NV 89512

R: WMPA23-0008 WRZA23-0009 Thompson Family Trust

Dear Kat,

In reviewing the Thompson Family Trust modification, the District has the following comment.

There are lots that will extend into the 30 percent open space area. While the District agrees that these lots will be deed restricted, we recommend signage for these lots on the open space indicating it is a non-built area. Typically, homeowners and the in-change ownership to homes over time, do not read the lot deed.

Thank you for providing us with the opportunity to review the modification and any questions call us at (775) 750-8272.

Sincerely,

Jim Shaffer

Date: September 15, 2023

To: Kat Oakley, Planner

From: Timber Weiss, P.E., Licensed Engineer

Re: Master Plan Amendment Case Number WMPA23-0008 and Regulatory Zone  
Amendment WRZA23-0009 (Thompson Family Trust)  
APNs 041-650-04 & 041-650-05

### **GENERAL PROJECT DISCUSSION**

For hearing, discussion, and possible action to ...

(1) Approve an amendment to the Southwest Area Plan, a component of the Washoe County Master Plan,

to redesignate 9.48 acres of two parcels totaling 81.83 acres from Rural (R) to Suburban Residential

(SR); and,

(2) Recommend adoption of an amendment to the Southwest Regulatory zone Map, to redesignate 9.48

acres of the same parcels from General Rural (GR) to Low Density Suburban (LDS); and

(3) If approved, authorize the chair to sign a resolution to this effect.

***The Community Services Department (CSD) recommends approval of this project with the following Water Rights conditions:***

Washoe County Department of Water Resources does not exist, and no water rights held under Washoe County are available for acquisition for this project. Water rights in good standing within the same hydrographic basin as this project must be acquired to the satisfaction of Truckee Meadows Water Authority.

A TMWA discovery process must be completed prior to these parcels being annexed into TMWA's service territory. The applicant shall conform with the requirements of TMWA in regard to water rights and water service. TMWA requires that all water service conditions to be met prior to approval of any subdivision of these parcels. Recommend approval of this permit, with written approval or will-serve from TMWA to provide service for the additional use on this property prior to any approval of the division of these parcels.

Project Name: \_\_\_\_\_  
Meeting Location: \_\_\_\_\_  
Meeting Date: \_\_\_\_\_

**Neighborhood Meeting  
SUMMARY**

Virtual Meeting Option Provided:      **YES**      **NO**  
Hosted By (Name): \_\_\_\_\_ (Company): \_\_\_\_\_  
Contact (Email): \_\_\_\_\_ (Phone): \_\_\_\_\_

.....

**Public Concerns:**

1. \_\_\_\_\_
2. \_\_\_\_\_
3. \_\_\_\_\_
4. \_\_\_\_\_
5. \_\_\_\_\_

**Changes Made to Proposal (if applicable):**

1. \_\_\_\_\_
2. \_\_\_\_\_
3. \_\_\_\_\_
4. \_\_\_\_\_
5. \_\_\_\_\_

**Any Additional Comments:**

\_\_\_\_\_  
\_\_\_\_\_  
\_\_\_\_\_  
\_\_\_\_\_  
\_\_\_\_\_

# Thompson Family Trust

Application to Washoe County for a:

## *Master Plan Amendment Regulatory Zone Amendment*

Prepared by:



John F. Krmptic, AICP  
KLS Planning & Design  
201 W Liberty Street, Suite 300  
Reno, NV 89501



Summit Engineering Corporation  
5405 Mae Anne Avenue  
Reno, NV 89523

Prepared for:

David Thompson  
PO Box 382  
Glenbrook, NV 89413

September 8, 2023

---

**Table of Contents**

Project Request ..... 1  
Property Location..... 1  
Land Use and Zoning..... 2  
Key Planning Issues ..... 6  
Hillside Analysis ..... 7  
Southwest Truckee Meadows Area Plan Findings ..... 8  
Master Plan Amendment Findings..... 11  
Regulatory Zone Amendment Findings ..... 12

**List of Figures**

Figure 1 – Vicinity Map ..... 1  
Figure 2 – Existing Zoning ..... 2  
Figure 3 – Existing Master Plan Land Use..... 3  
Figure 4 – Proposed Zoning ..... 4  
Figure 5 – Proposed Master Plan Land Use..... 5  
Figure 6 – Slope Map..... 7

**Appendix**

**Application Materials**

- WC Development Application
- Master Plan Amendment – Supplemental Information
- Regulatory Zone Amendment – Supplemental Information
- Property Owner Affidavit
- WC Fee Sheet
- WC Treasurer – Tax Payment Records
- WC Predevelopment Worksheet
- Planning Commission Staff Report – Ridges at Hunter Creek (dated June 14, 2016 – Tentative Map approval is included for reference as the source and basis of public infrastructure and public facility connections for the subject amendments)
- Utility Service Feasibility Report

## Project Request

This application contains two requests:

1. A **Master Plan Amendment** to change the Master Plan land use designation of a portion of the site from Rural (R) to Suburban Residential (SR); and
2. A **Regulatory Zone Amendment** to change a portion of the site zoning from General Rural (GR) to Low Density Residential (LDS).

The site is part of the South West Truckee Meadows (SWTM) Area Plan and specific to the West Truckee Meadows Wildland Transition Suburban Character Management Area. The requests are being driven to allow for the development of eight single family lots.

## Project Location

The site is located about 1.2 miles south of the intersection of Mayberry Drive and Plateau Road. It will be accessed from Hunters Peak Road, which connects to Plateau Road via Woodchuck Circle. The site includes two parcels, APN 041-650-04 and 041-650-05, and consists of 81.83 acres as shown in Figure 1 (below).

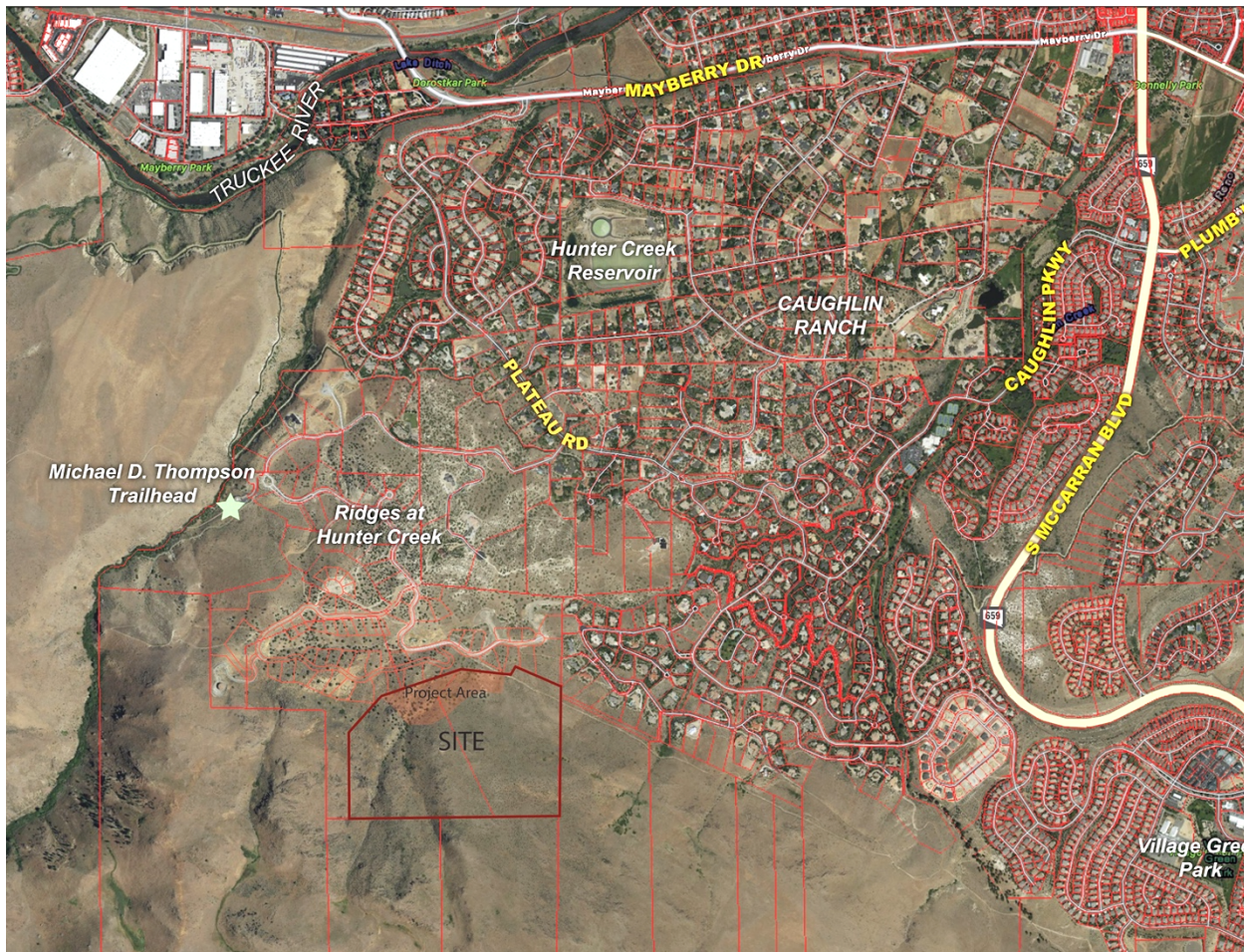

Figure 1 – Vicinity Map



**Land Use and Zoning**

The site is vacant with surrounding conditions that are bordering existing single-family land uses. Residential is adjacent on the north and east sides with a mix of HDR and LDS zoning and SR and RR land use, as seen in Figures 2 and 3 below.

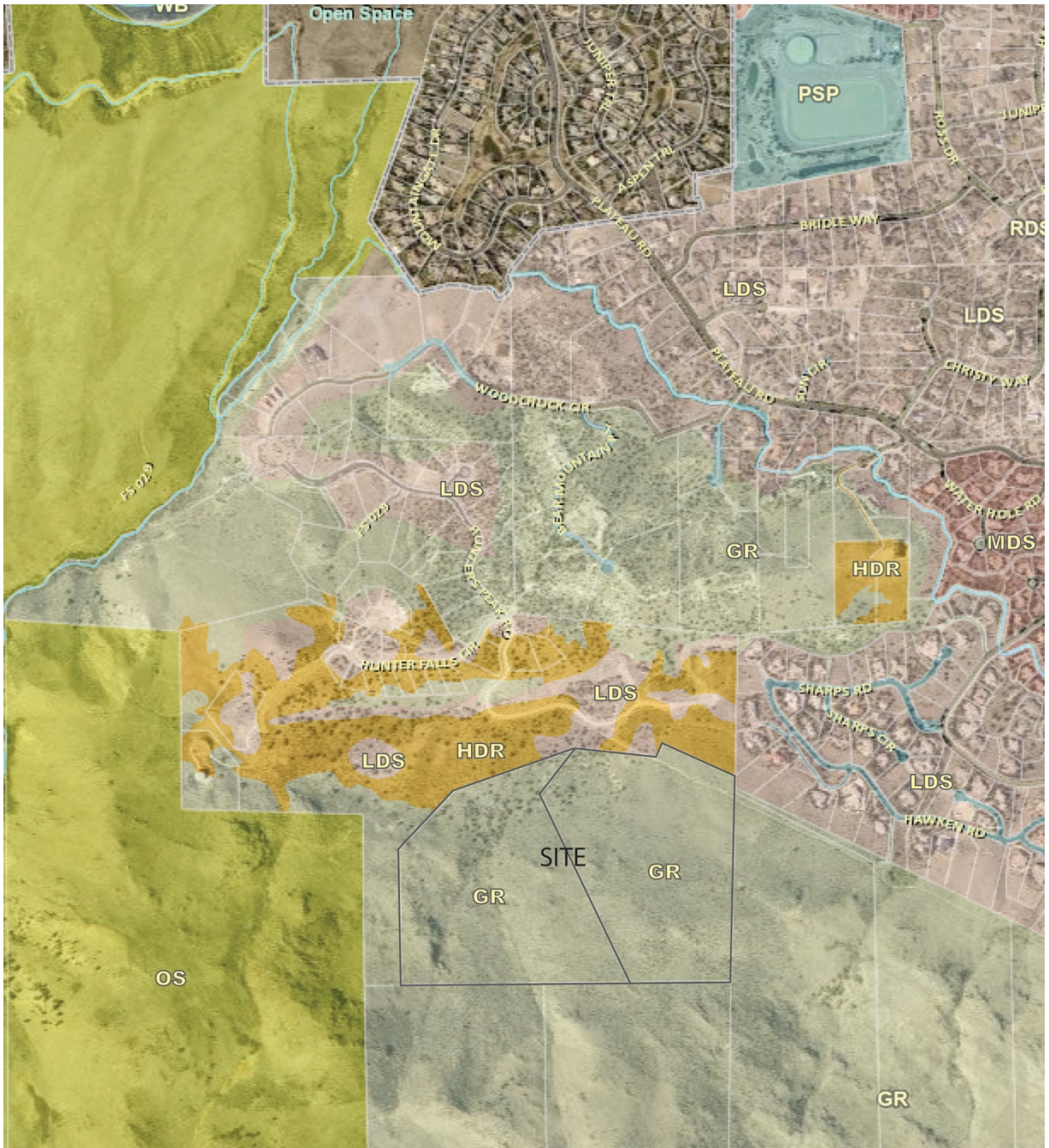

Figure 2 – Existing Zoning

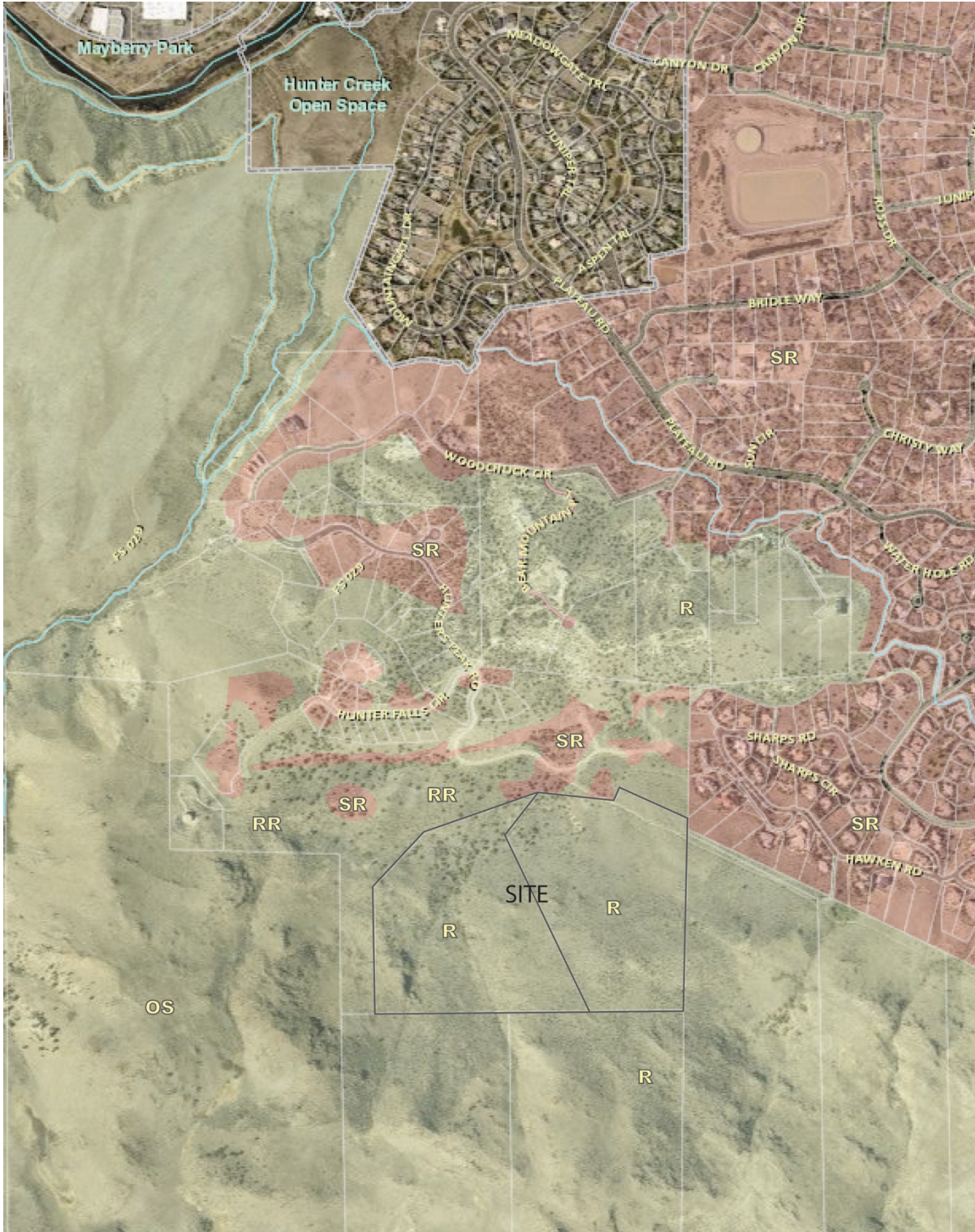

Figure 3 – Existing Land Use Designations

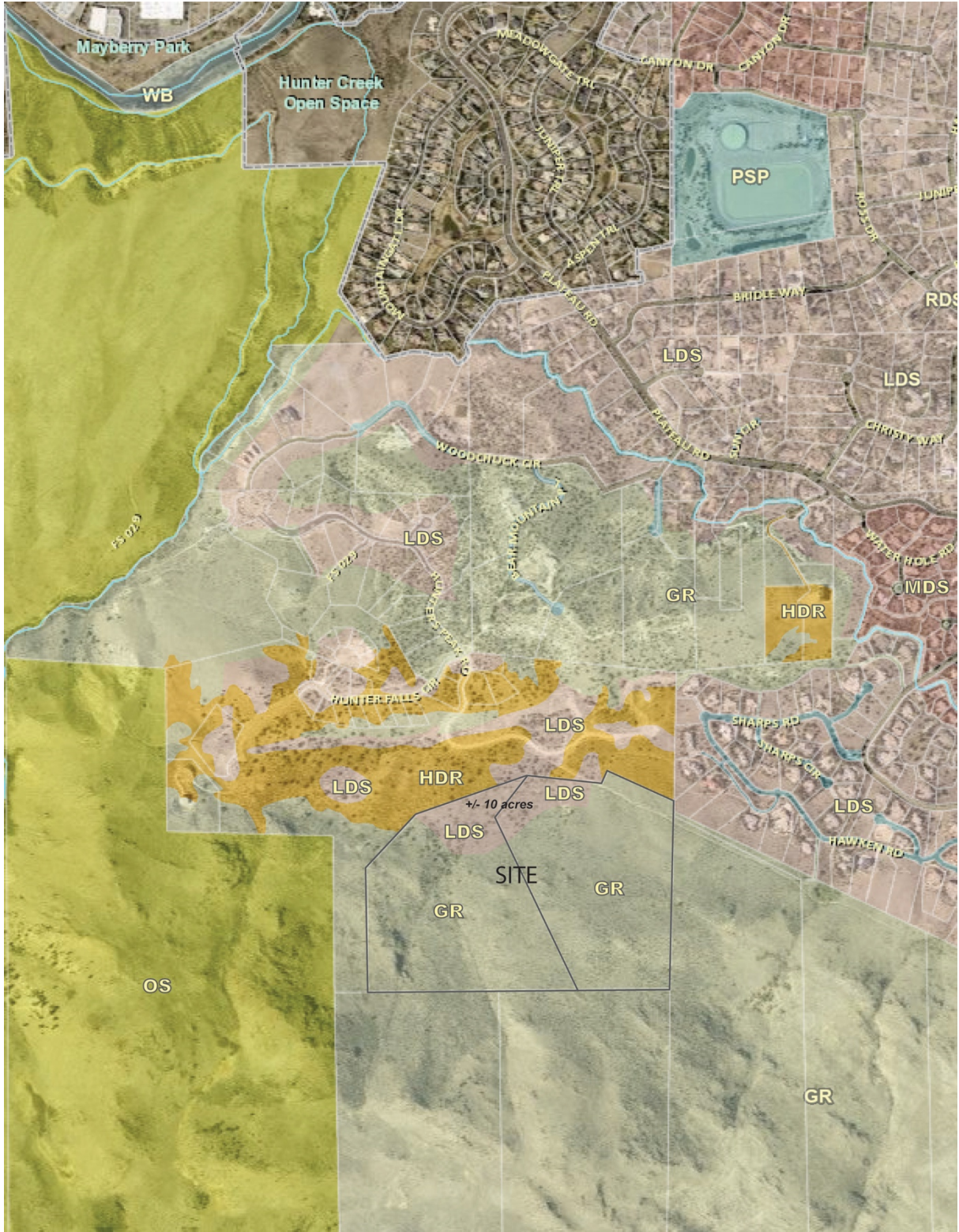

Figure 4 – Proposed Zoning Map



Figure 5 – Proposed Land Use Designations

## Key Planning Issues

The followings points are to identify the key issues to be addressed with staff and public review to approve this request:

- Land Use Compatibility – Surrounding land uses are primarily residential and Open Space. They are highly compatible with the density resulting from the proposed policy change. Abutting the north boundary is LDS and HDR zoning that defines the area as a suburban land use. This policy change will have no impact on compatibility as all resulting density will fall within the LDS limits as established.
- Density – There is a solid argument that the land use change for a focused portion of the site is appropriate and consistent with 1-acre single family lotting as established in this area. This proposal is typical and appropriate in managing the land use and density discussions.
- Policy support for this use is noted in the West Truckee Meadows Wildland Transition Suburban Character Management Area of the Southwest Truckee Meadows Area Plan and will potentially affect other vacant GR parcels in the Character Management Area. This will be vetted in the public process of this amendment request.
- Hillside – Our development plan is a textbook fit to the hillside development code by using only 11.5% of the site and assigning the remaining constrained area to undisturbed Open Space. This will end the intensification of land further up the hill and draws a clear boundary between the land that is suitable for development and the land that has natural resource value in open space.

Hillside Analysis

The conceptual land plan for the parcel shows the abutting existing development. This is the basis for the project as envisioned to respect and assign the topographic constraints in open space. The slope calculations show all of the building footprints, roads, driveways and grading in the 0 to 20% land and everything else in open space. setbacks are shown and respected in the lotting plan.

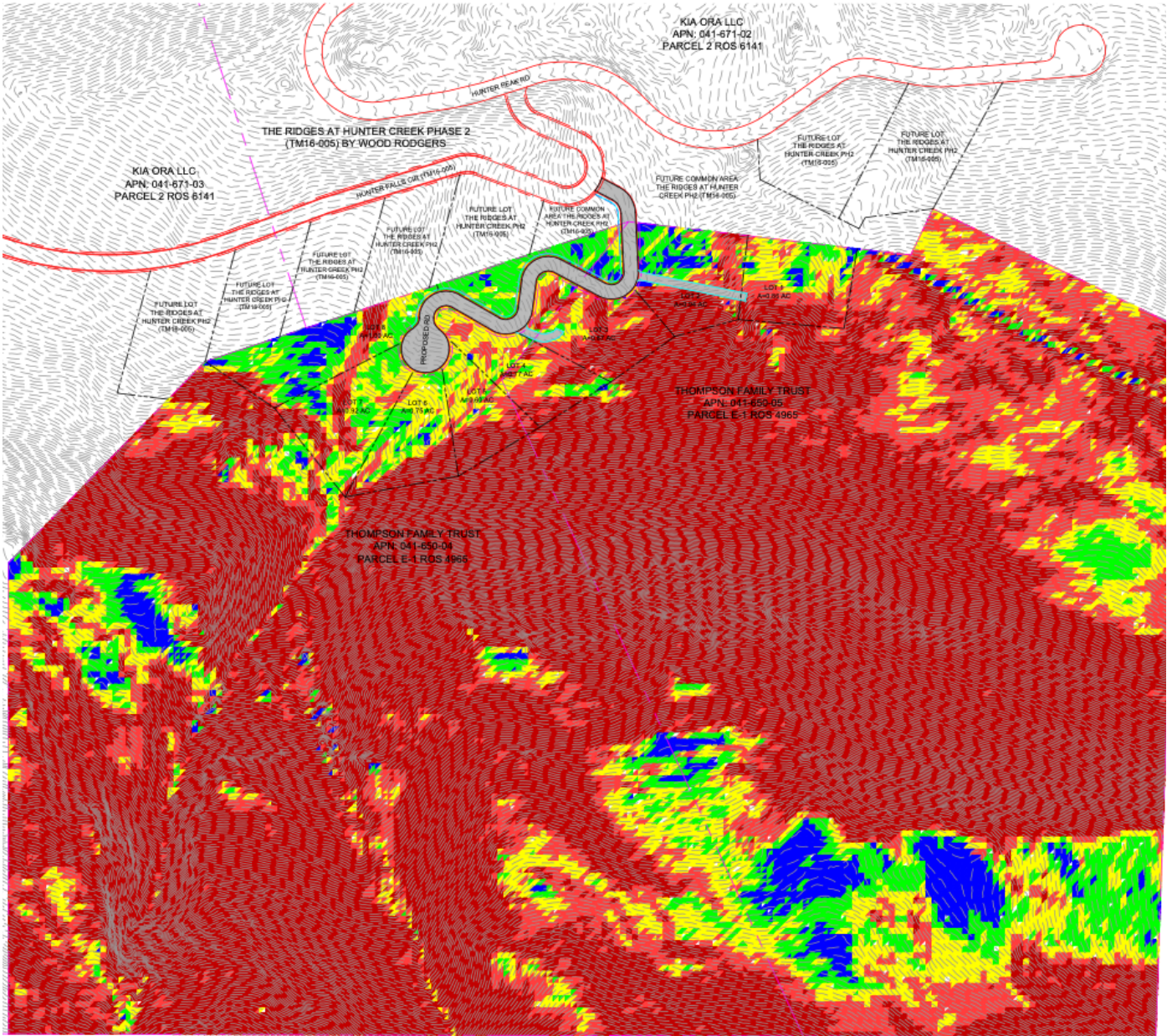

Figure 6 – Slope Map

## SWTM Area Plan Findings

### Plan Maintenance

**Goal Twenty: Amendments to the SWTM Area Plan will be for the purpose of further implementing the Vision and Character Statement, or to respond to new or changing circumstances. Amendments will conform to the SWTM Vision and Character Statement. Amendments will be reviewed against a set of criteria and thresholds that are measures of the impact on, or progress toward, the Vision and Character Statement.**

### Policies

SW.20.1 In order for the Washoe County Planning Commission to recommend the approval of ANY amendment to the SWTM Area Plan, the following findings must be made:

- a. The amendment will further implement and preserve the Vision and Character Statement.

*The amendment implements the SWTM Area Plan Vision and Character Statement as it maintains and preserves the planning area's character while providing housing opportunities that are appropriate in scale to the surrounding community.*

- b. The amendment conforms to all applicable policies of the SWTM Area Plan and the Washoe County Master Plan, and the Regional Water Management Plan.

*We believe this amendment conforms with all applicable policies of the SWTM Area Plan, the WC Master Plan, and the Regional Water Management Plan, as discussed in this application.*

- c. The amendment will not conflict with the public's health, safety or welfare.

*There is no conceivable detriment to the public health, safety, and welfare of any citizens with this proposed amendment.*

SW.20.2 For any amendment that proposes to:

- Revise the Vision and Character statement; **(not applicable)**
- Revise Goal One or its associated policies; **(not applicable)**

The Washoe County Planning Commission must find that the Department of Community Development has conducted a series of community visioning workshops with the appropriate Citizen Advisory Board (CAB) and the results of that process, including any CAB and staff recommendations, have been included and discussed in the staff analysis of the proposed amendment. Proposals to alter the boundaries of an identified character management area must be accompanied by a proposed land use change, and the land use proposal must meet all of the applicable policies of the SWTM Area Plan.

SW.20.3 In order for the Washoe County Planning Commission to recommend approval of any amendment involving a change of land use, the following findings must be made:

- a. The impacts of the amendment are within commonly accepted thresholds of sustainable resource management and the county's ability to manage the conservation of the area's character will not be compromised.

*The proposed zoning is permitted in the site's SCMA and is therefore within the accepted threshold of resource management. The area's character will not be compromised with the proposed amendment.*

- b. A feasibility study has been conducted, commissioned and paid for by the applicant, relative to municipal water, sewer and storm water that clearly identifies the improvements likely to be required to support the intensification, and those improvements have been determined to be in substantial compliance with all applicable existing facilities and resource plans for SWTM by the Department of Water Resources. The Department of Water Resources will establish and maintain the standards and methodologies for these feasibility studies.

*A feasibility study has been conducted by the applicant and all required improvements are understood to be compliant with the Department of Water Resources criteria.*

- c. A traffic analysis has been conducted that clearly identifies the impact to the adopted level of service within the Southwest Truckee Meadows planning area and the improvements likely to be required to maintain/achieve the adopted level of service. This finding may be waived by the Department of Public Works for projects that are determined to have minimal impacts. The Department of Public Works may request any information it deems necessary to make this determination.

*This is a low intensity development with few weekday trips and minimal impact expected. We will provide a traffic analysis if necessary.*

- d. For amendments that propose new or intensified commercial land use, the scale of the intended use shall be shown to be community serving in nature. Casinos are not appropriate in the Southwest Truckee Meadows planning area.

*Not applicable, not a commercial land use.*

- e. For residential land use intensifications, the potential increase in residential units will not exceed Washoe County's applicable policy growth level for the SWTM Area Plan, as established under Goal One.

*The LDS zone is permitted in the SWTM Area Plan for the West Truckee Meadows Wildland Transition SCMA with a density growth level of one unit per 1 acre, which the project does not exceed.*

- f. If the proposed intensification will result in a drop below the established policy level of service for transportation (as established by the Regional Transportation Commission and Washoe County) within the Southwest Truckee Meadows planning area, the necessary improvements required to maintain the established level of service are scheduled in either the Washoe County Capital Improvements Program or Regional Transportation Improvement Program within three years of approval of the



intensification. For impacts to regional roads, the Washoe County Planning Commission, upon written request from the Regional Transportation Commission, may waive this finding.

*Not applicable, does not result in a drop below the established level of service for transportation.*

- g. If roadways impacted by the proposed intensification are currently operating below adopted levels of service, the intensification will not require infrastructure improvements beyond those articulated in Washoe County and regional transportation plans AND the necessary improvements are scheduled in either the Washoe County Capital Improvements Program or Regional Transportation Improvement Program within three years of approval of the intensification.

*The roadways impacted will not require infrastructure improvements beyond those in the WC and regional transportation plans.*

- h. Proposed amendments shall complement the long-range plans of facilities providers for transportation, water resources, schools and parks as reflected in the policy growth level established in Policy 1.2.

*The proposed amendment complements the long-range plans of facilities for this zone as it is within its established policy growth level.*

- i. If the proposed intensification results in existing public school facilities exceeding design capacity and compromises the Washoe County School District's ability to implement the neighborhood school philosophy for elementary facilities, then there must be a current capital improvement plan or rezoning plan in place that would enable the District to absorb the additional enrollment. The Washoe County Planning Commission, upon request of the Washoe County School Board of Trustees, may waive this finding.

*The proposed amendment will not result in existing public school facilities exceeding design capacity.*

- j. Any existing development in the Southwest Truckee Meadows planning area, the South Valleys planning area, the Forest planning area, or the Southeast Truckee Meadows planning area which is subject to the conditions of a special use permit will not experience undue hardship in its ability to continue to comply with the conditions of the special use permit or otherwise to continue operation of its permitted activities.

*There is no existing development in the planning area that will experience undue hardship under permitted activities or those under a special use permit as a result of this amendment.*

SW.20.4 For proposals to establish or intensify commercial land uses, the applicant shall provide a market analysis, articulating the anticipated trade area, providing convincing evidence of a need to increase the inventory of commercial land use opportunities, and otherwise demonstrating the scale of the intended use to be community serving in nature. **(not applicable)**

SW.20.5 The Department of Community Development will provide the Planning Commission with a status report on the implementation of this plan no later than 24 months from the date of adoption.

### Master Plan Amendment Findings

**Findings.** When adopting an amendment, the Commission shall make all required findings contained in the area plan for the planning area in which the property that is the subject of the Master Plan amendment is located and, at a minimum, make at least three of the following findings of fact unless a military installation is required to be noticed, then in addition to the above, a finding of fact pursuant to subsection (6) shall also be made:

- (1) **Consistency with Master Plan.** The proposed amendment is in substantial compliance with the policies and action programs of the Master Plan.

*The proposed amendment is in substantial compliance with all policies and action programs of the Master Plan as discussed in the supplemental information document.*

- (2) **Compatible Land Uses.** The proposed amendment will provide for land uses compatible with (existing or planned) adjacent land uses, and will not adversely impact the public health, safety or welfare.

*The proposed regulatory zones are permitted in the site's Suburban Character Management Area. The proposed land use has been established for adjacent sites, making it highly compatible. There is no conceivable detriment to public health, safety, or welfare.*

- (3) **Response to Change Conditions.** The proposed amendment responds to changed conditions or further studies that have occurred since the plan was adopted by the Board of County Commissioners, and the requested amendment represents a more desirable utilization of land.

*The site's surrounding conditions have changed as new residential development has been approved directly adjacent to the site. This created the opportunity for this land to be utilized in a similar nature with low density residential units restricted to the flattest portion of the site in proximity to the new development.*

- (4) **Availability of Facilities.** There are or are planned to be adequate transportation, recreation, utility, and other facilities to accommodate the uses and densities permitted by the proposed Master Plan designation.

*All facilities are planned to extend from existing lines at Hunter Creek Road and any improvements will be designed to accommodate the SR Master Plan designation.*

- (5) **Desired Pattern of Growth.** The proposed amendment will promote the desired pattern for the orderly physical growth of the County and guides development of the County based

on the projected population growth with the least amount of natural resource impairment and the efficient expenditure of funds for public services.

*The proposed development's design is based on the surrounding's land pattern of growth that has recently been approved by Washoe County.*

- (6) **Effect on a Military Installation.** The proposed amendment will not affect the location, purpose and mission of the military installation.

*The proposed amendment will not affect the location, purpose, and mission of the military installation.*

## Regulatory Zone Amendment Findings

**Findings.** To make a recommendation for approval, all of the following findings must be made by the Commission:

- (1) **Consistency with Master Plan.** The proposed amendment is in substantial compliance with the policies and actions of the Master Plan.

*The proposed amendment is in substantial compliance with all policies and action programs of the Master Plan as discussed in the supplemental information document.*

- (2) **Compatible Land Uses.** The proposed amendment will provide for land uses compatible with (existing or planned) adjacent land uses, and will not adversely impact the public health, safety or welfare.

*The proposed regulatory zones are permitted in the site's Suburban Character Management Area. The proposed zoning has been established for adjacent sites, making it highly compatible. There is no conceivable detriment to public health, safety, or welfare.*

- (3) **Response to Change Conditions; more desirable use.** The proposed amendment responds to changed conditions or further studies that have occurred since the plan was adopted by the Board of County Commissioners, and the requested amendment represents a more desirable utilization of land.

*The site's surrounding conditions have changed as new residential development has been approved directly adjacent to the site. This created the opportunity for this land to be utilized in a similar nature with low density residential units restricted to the flattest portion of the site near and adjacent to the new development.*

- (4) **Availability of Facilities.** There are or are planned to be adequate transportation, recreation, utility, and other facilities to accommodate the uses and densities permitted by the proposed amendment.

*All facilities are planned to extend from existing lines at Hunter Creek Road and any improvements will be designed to accommodate the LDS zoning designation.*

- (5) **No Adverse Effects.** The proposed amendment will not adversely affect the implementation of the policies and action programs of the Washoe County Master Plan.

*There is no foreseeable adverse effect on the policies and actions of the Washoe County Master Plan due to this proposed amendment.*

- (6) **Desired Pattern of Growth.** The proposed amendment will promote the desired pattern for the orderly physical growth of the County and guides development of the County based on the projected population growth with the least amount of natural resource impairment and the efficient expenditure of funds for public services.

*The proposed development's design is based on the surrounding's land pattern of growth that has recently been approved by Washoe County.*

- (7) **Effect on a Military Installation When a Military Installation is Required to be Noticed.** The proposed amendment will not affect the location, purpose and mission of a military installation.

*The proposed amendment will not affect the location, purpose and mission of a military installation.*

## Appendix

### Application Materials

WC Development Application

Master Plan Amendment – Supplemental Information

Regulatory Zone Amendment – Supplemental Information

Property Owner Affidavit

WC Fee Sheet

WC Treasurer – Tax Payment Records

WC Predevelopment Worksheet

Planning Commission Staff Report – Ridges at Hunter Creek (dated June 14, 2016 – Tentative Map approval is included for reference as the source and basis of public infrastructure and public facility connections for the subject amendments)

Utility Service Feasibility Report

## Washoe County Development Application

Your entire application is a public record. If you have a concern about releasing personal information, please contact Planning and Building staff at 775.328.6100.

|                                                                                                 |                 |                                           |                 |
|-------------------------------------------------------------------------------------------------|-----------------|-------------------------------------------|-----------------|
| <b>Project Information</b>                                                                      |                 | Staff Assigned Case No.: _____            |                 |
| Project Name:                                                                                   |                 |                                           |                 |
| Project Description:                                                                            |                 |                                           |                 |
| Project Address:                                                                                |                 |                                           |                 |
| Project Area (acres or square feet):                                                            |                 |                                           |                 |
| Project Location (with point of reference to major cross streets <b>AND</b> area locator):      |                 |                                           |                 |
| Assessor's Parcel No.(s):                                                                       | Parcel Acreage: | Assessor's Parcel No.(s):                 | Parcel Acreage: |
|                                                                                                 |                 |                                           |                 |
| Indicate any previous Washoe County approvals associated with this application:<br>Case No.(s). |                 |                                           |                 |
| <b>Applicant Information</b> (attach additional sheets if necessary)                            |                 |                                           |                 |
| <b>Property Owner:</b>                                                                          |                 | <b>Professional Consultant:</b>           |                 |
| Name:                                                                                           |                 | Name:                                     |                 |
| Address:                                                                                        |                 | Address:                                  |                 |
| Zip:                                                                                            |                 | Zip:                                      |                 |
| Phone:                      Fax:                                                                |                 | Phone:                      Fax:          |                 |
| Email:                                                                                          |                 | Email:                                    |                 |
| Cell:                              Other:                                                       |                 | Cell:                              Other: |                 |
| Contact Person:                                                                                 |                 | Contact Person:                           |                 |
| <b>Applicant/Developer:</b>                                                                     |                 | <b>Other Persons to be Contacted:</b>     |                 |
| Name:                                                                                           |                 | Name:                                     |                 |
| Address:                                                                                        |                 | Address:                                  |                 |
| Zip:                                                                                            |                 | Zip:                                      |                 |
| Phone:                      Fax:                                                                |                 | Phone:                      Fax:          |                 |
| Email:                                                                                          |                 | Email:                                    |                 |
| Cell:                              Other:                                                       |                 | Cell:                              Other: |                 |
| Contact Person:                                                                                 |                 | Contact Person:                           |                 |
| <b>For Office Use Only</b>                                                                      |                 |                                           |                 |
| Date Received:                      Initial:                                                    |                 | Planning Area:                            |                 |
| County Commission District:                                                                     |                 | Master Plan Designation(s):               |                 |
| CAB(s):                                                                                         |                 | Regulatory Zoning(s):                     |                 |

# Master Plan Amendment Supplemental Information

(All required information may be separately attached)

The Washoe County Master Plan describes how the physical character of the County exists today and is planned for the future. The plan is adopted by the community and contains information, policies and a series of land use maps. The Master Plan provides the essential framework for creating a healthy community system and helps guide decisions about growth and development in the County. The following are general types of requests the County receives to amend the Master Plan. Please identify which type of amendment you are requesting:

|                                                                                                                                                                   |
|-------------------------------------------------------------------------------------------------------------------------------------------------------------------|
| <input type="checkbox"/> A request to change a master plan designation(s) from the adopted master plan and/or area plan maps                                      |
| <input type="checkbox"/> A request to add, amend, modify or delete any of the adopted policies found in the elements of the Master Plan                           |
| <input type="checkbox"/> A request to add, amend, modify or delete any of the adopted policies in the area plans and/or specific language found in the area plans |
| <input type="checkbox"/> Other (please identify):                                                                                                                 |

Please complete this questionnaire to ensure consistent review of your request to amend the Washoe County Master Plan. Staff will review the application to determine if the amendment request is in conformance with the policies and language within the elements and area plans of the Master Plan or if the information provided supports a change to the plan. Please provide an explanation to all questions; attach additional sheets if necessary.

1. What is the Master Plan amendment being requested at this time?

|  |
|--|
|  |
|--|

2. What conditions have changed and/or new studies have occurred since the adoption of the Washoe County Master Plan that supports the need for the amendment request?

|  |
|--|
|  |
|--|

3. Please provide the following specific information:

a. What is the location (address or distance and direction from the nearest intersection of the subject property)? Attach, for map amendments, a legal description. For all other amendments, what is the area subject to the request?

|  |
|--|
|  |
|--|

b. Please list the following proposed changes (attach additional sheet if necessary):

| Assessor's Parcel Number | Master Plan Designation | Existing Acres | Proposed Master Plan Designation | Proposed Acres |
|--------------------------|-------------------------|----------------|----------------------------------|----------------|
|                          |                         |                |                                  |                |
|                          |                         |                |                                  |                |
|                          |                         |                |                                  |                |
|                          |                         |                |                                  |                |
|                          |                         |                |                                  |                |
|                          |                         |                |                                  |                |
|                          |                         |                |                                  |                |
|                          |                         |                |                                  |                |

c. What are the adopted land use designations of adjacent parcels?

|       |  |
|-------|--|
| North |  |
| South |  |
| East  |  |
| West  |  |

4. Describe the existing conditions and uses located at the site or in the vicinity (i.e. vacant land, roadways, buildings, etc.).

5. Describe the natural resources associated with the site under consideration. Your description should include resource characteristics such as water bodies, vegetation, topography, minerals, soils and wildlife habitat.

The significant natural resources are topography and vegetation. The site does not contain any water bodies, minerals, or soils of note. Our approach to this amendment is a focused development plan to minimize disruption to natural resources.

6. Describe whether any of the following natural resources or systems are related to the proposed amendment:

a. Is property located in the 100-year floodplain? (If yes, attach documentation of the extent of the floodplain and any proposed floodplain map revisions in compliance with Washoe County Development Code, Article 416, Flood Hazards, and consultation with the Washoe County Engineering & Capital Projects Division.)

|                              |                             |
|------------------------------|-----------------------------|
| <input type="checkbox"/> Yes | <input type="checkbox"/> No |
|------------------------------|-----------------------------|

Explanation:

b. Does property contain wetlands? (If yes, attach a preliminary delineation map and describe the impact the proposal will have on the wetlands. Impacts to the wetlands may require a permit issued from the U.S. Army Corps of Engineers.)

|                              |                             |
|------------------------------|-----------------------------|
| <input type="checkbox"/> Yes | <input type="checkbox"/> No |
|------------------------------|-----------------------------|



Explanation:

- c. Does the property contain slopes or hillsides in excess of 15 percent and/or significant ridgelines? (If yes, submit the slope analysis requirements as contained in Article 424, Hillside Development of the Washoe County Development Code.)

|                              |                             |
|------------------------------|-----------------------------|
| <input type="checkbox"/> Yes | <input type="checkbox"/> No |
|------------------------------|-----------------------------|

Explanation:

- d. Does the property contain geologic hazards such as active faults, hillside, or mountainous areas? Is it subject to avalanches, landslides, or flash floods? Near a stream or riparian area such as the Truckee River, and/or an area of groundwater recharge? If the answer is yes to any of the above, check yes and provide an explanation.

|                              |                             |
|------------------------------|-----------------------------|
| <input type="checkbox"/> Yes | <input type="checkbox"/> No |
|------------------------------|-----------------------------|

Explanation:

- e. Does the property contain prime farmland, within a wildfire hazard area, geothermal or mining area, and/or wildlife mitigation route? If the answer is yes to any of the above, check yes and provide an explanation.

|                              |                             |
|------------------------------|-----------------------------|
| <input type="checkbox"/> Yes | <input type="checkbox"/> No |
|------------------------------|-----------------------------|

Explanation:

- 7. Are any archaeological, historic, cultural, or scenic resources in the vicinity or associated with the proposed amendment? If the answer is yes to any of the above, check yes and provide an explanation.

|                              |                             |
|------------------------------|-----------------------------|
| <input type="checkbox"/> Yes | <input type="checkbox"/> No |
|------------------------------|-----------------------------|

Explanation:

- 8. Do you own sufficient water rights to accommodate the proposed amendment? (Amendment requests in some groundwater hydrographic basins [e.g. Cold Springs, Warm Springs, etc.] require proof of water rights be submitted with applications. Provide copies of all water rights documents, including chain of title to the original water right holder.)

|                              |                             |
|------------------------------|-----------------------------|
| <input type="checkbox"/> Yes | <input type="checkbox"/> No |
|------------------------------|-----------------------------|

If yes, please identify the following quantities and documentation numbers relative to the water rights. Please attach a copy(s) of the water rights title (as filed with the State Engineer in the Division of Water Resources of the Department of Conservation and Natural Resources).

|                    |  |                    |  |
|--------------------|--|--------------------|--|
| a. Permit #        |  | acre-feet per year |  |
| b. Certificate #   |  | acre-feet per year |  |
| c. Surface Claim # |  | acre-feet per year |  |
| d. Other #         |  | acre-feet per year |  |

- a. If the proposed amendment involves an intensification of land use, please identify how sufficient water rights will be available to serve the additional development.

|  |
|--|
|  |
|--|

9. Please describe the source and timing of the water facilities necessary to serve the amendment.

- a. System Type:

|                                           |           |  |
|-------------------------------------------|-----------|--|
| <input type="checkbox"/> Individual wells |           |  |
| <input type="checkbox"/> Private water    | Provider: |  |
| <input type="checkbox"/> Public water     | Provider: |  |

- b. Available:

|                              |                                    |                                    |                                   |
|------------------------------|------------------------------------|------------------------------------|-----------------------------------|
| <input type="checkbox"/> Now | <input type="checkbox"/> 1-3 years | <input type="checkbox"/> 3-5 years | <input type="checkbox"/> 5+ years |
|------------------------------|------------------------------------|------------------------------------|-----------------------------------|

- c. If a public facility is proposed and is currently not available, please describe the funding mechanism for ensuring availability of water service.

|  |
|--|
|  |
|--|

10. What is the nature and timing of sewer services necessary to accommodate the proposed amendment?

- a. System Type:

|                                            |           |  |
|--------------------------------------------|-----------|--|
| <input type="checkbox"/> Individual septic |           |  |
| <input type="checkbox"/> Public system     | Provider: |  |

- b. Available:

|                              |                                    |                                    |                                   |
|------------------------------|------------------------------------|------------------------------------|-----------------------------------|
| <input type="checkbox"/> Now | <input type="checkbox"/> 1-3 years | <input type="checkbox"/> 3-5 years | <input type="checkbox"/> 5+ years |
|------------------------------|------------------------------------|------------------------------------|-----------------------------------|

- c. If a public facility is proposed and is currently not available, please describe the funding mechanism for ensuring availability of sewer service. If a private system is proposed, please describe the system and the recommended location(s) for the proposed facility.

|  |
|--|
|  |
|--|

11. Please identify the street names and highways near the proposed amendment that will carry traffic to the regional freeway system.

|  |
|--|
|  |
|--|

12. Will the proposed amendment impact existing or planned transportation systems? (If yes, a traffic report will be required.)

|                              |                             |
|------------------------------|-----------------------------|
| <input type="checkbox"/> Yes | <input type="checkbox"/> No |
|------------------------------|-----------------------------|

13. Community Services (provided and nearest facility):

|                         |  |
|-------------------------|--|
| a. Fire Station         |  |
| b. Health Care Facility |  |
| c. Elementary School    |  |
| d. Middle School        |  |
| e. High School          |  |
| f. Parks                |  |
| g. Library              |  |
| h. Citifare Bus Stop    |  |

14. Describe how the proposed amendment fosters, promotes, or complies with the policies of the adopted area plans and elements of the Washoe County Master Plan.

a. Population Element:

|  |
|--|
|  |
|--|

b. Conservation Element:

|  |
|--|
|  |
|--|

c. Housing Element:

|  |
|--|
|  |
|--|

d. Land Use and Transportation Element:

|  |
|--|
|  |
|--|

e. Public Services and Facilities Element:

|  |
|--|
|  |
|--|

f. Adopted area plan(s):

|  |
|--|
|  |
|--|

15. If the area plan includes a Plan Maintenance component, address all policies and attach all studies and analysis required by the Plan Maintenance criteria.

|  |
|--|
|  |
|--|

### **Applicant Comments**

This page can be used by the applicant to support the master plan amendment request and should address, at a minimum, how one or more of the findings for an amendment is satisfied. (Please refer to Article 820 of the Washoe County Development Code for the list of Findings.)

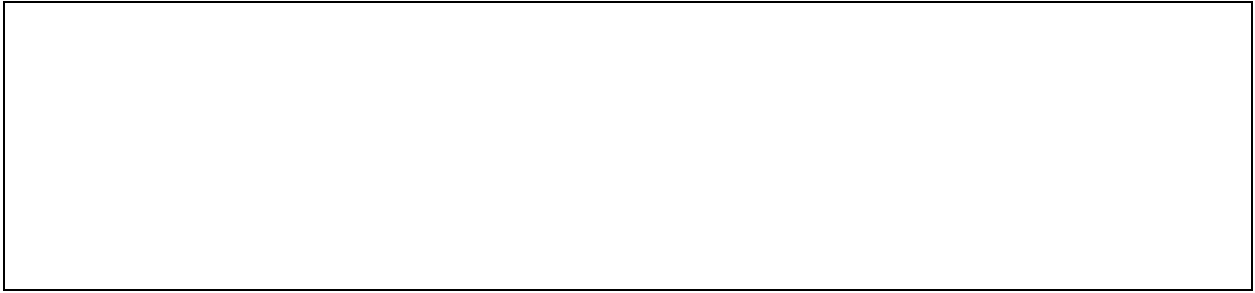

# Regulatory Zone Amendment Supplemental Information

(All required information may be separately attached)

Please complete the following supplemental information to ensure consistent review of your request to amend the Washoe County Zoning Map. Please provide a brief explanation to all questions answered in the affirmative.

1. List the Following information regarding the property subject to the Regulatory Zone Amendment.
  - a. What is the location (address, distance and direction from nearest intersection)?

- b. Please list the following proposed changes (attach additional sheet if necessary).

| APN of Parcel | Master Plan Designation | Current Zoning | Existing Acres | Proposed Zoning | Proposed Acres |
|---------------|-------------------------|----------------|----------------|-----------------|----------------|
|               |                         |                |                |                 |                |
|               |                         |                |                |                 |                |
|               |                         |                |                |                 |                |
|               |                         |                |                |                 |                |
|               |                         |                |                |                 |                |
|               |                         |                |                |                 |                |
|               |                         |                |                |                 |                |
|               |                         |                |                |                 |                |
|               |                         |                |                |                 |                |
|               |                         |                |                |                 |                |

- c. What are the regulatory zone designations of adjacent parcels?

|       | Zoning | Use (residential, vacant, commercial, etc.) |
|-------|--------|---------------------------------------------|
| North |        |                                             |
| South |        |                                             |
| East  |        |                                             |
| West  |        |                                             |

3. Describe the existing conditions and uses located on the site (i.e. vacant land, roadways, easements, buildings, etc.).

4. Describe the natural resources associated with the site under consideration. Your description should include resource characteristics such as water bodies, vegetation, topography, minerals, soils, and wildlife habitat.

The significant natural resources are topography and vegetation. The site does not contain any water bodies, minerals, or soils of note. Our approach to this amendment is a focused development plan to minimize disruption to natural resources.

5. Does the property contain development constraints such as floodplain or floodways, wetlands, slopes, or hillsides in excess of 15%, geologic hazards such as active faults, significant hydrologic resources, or major drainages or prime farmland?

|                                                                 |                             |
|-----------------------------------------------------------------|-----------------------------|
| <input type="checkbox"/> Yes, provide map identifying locations | <input type="checkbox"/> No |
|-----------------------------------------------------------------|-----------------------------|

6. Is the site located in an area where there is potentially an archeological, historic, or scenic resource?

|                              |                             |
|------------------------------|-----------------------------|
| <input type="checkbox"/> Yes | <input type="checkbox"/> No |
|------------------------------|-----------------------------|

Explanation:

|  |
|--|
|  |
|--|

7. Are there sufficient water rights to accommodate the proposed amendment? Please provide copies of all water rights documents, including chain of title to the original water right holder.)

|                              |                             |
|------------------------------|-----------------------------|
| <input type="checkbox"/> Yes | <input type="checkbox"/> No |
|------------------------------|-----------------------------|

If yes, please identify the following quantities and documentation numbers relative to the water rights:

|                    |  |                    |  |
|--------------------|--|--------------------|--|
| a. Permit #        |  | acre-feet per year |  |
| b. Certificate #   |  | acre-feet per year |  |
| c. Surface Claim # |  | acre-feet per year |  |
| d. Other #         |  | acre-feet per year |  |

- a. Title of those rights (as filed with the State Engineer in the Division of Water Resources of the Department of Conservation and Natural Resources):

|  |
|--|
|  |
|--|

- b. If the proposed amendment involves an intensification of land use, please identify how sufficient water rights will be available to serve the additional development.

|  |
|--|
|  |
|--|

8. Please describe the source and timing of the water facilities necessary to serve the amendment.

- a. System Type:

|                                           |           |  |
|-------------------------------------------|-----------|--|
| <input type="checkbox"/> Individual wells |           |  |
| <input type="checkbox"/> Private water    | Provider: |  |
| <input type="checkbox"/> Public water     | Provider: |  |

- b. Available:

|                              |                                    |                                    |                                   |
|------------------------------|------------------------------------|------------------------------------|-----------------------------------|
| <input type="checkbox"/> Now | <input type="checkbox"/> 1-3 years | <input type="checkbox"/> 3-5 years | <input type="checkbox"/> 5+ years |
|------------------------------|------------------------------------|------------------------------------|-----------------------------------|

- c. Is this part of a Washoe County Capital Improvements Program project?

|                              |                             |
|------------------------------|-----------------------------|
| <input type="checkbox"/> Yes | <input type="checkbox"/> No |
|------------------------------|-----------------------------|

- d. If a public facility is proposed and is currently not listed in the Washoe County Capital Improvements Program or not available, please describe the funding mechanism for ensuring availability of water service.

|  |
|--|
|  |
|--|

9. What is the nature and timing of sewer services necessary to accommodate the proposed amendment?

- a. System Type:

|                                            |           |  |
|--------------------------------------------|-----------|--|
| <input type="checkbox"/> Individual septic |           |  |
| <input type="checkbox"/> Public system     | Provider: |  |

- b. Available:

|                              |                                    |                                    |                                   |
|------------------------------|------------------------------------|------------------------------------|-----------------------------------|
| <input type="checkbox"/> Now | <input type="checkbox"/> 1-3 years | <input type="checkbox"/> 3-5 years | <input type="checkbox"/> 5+ years |
|------------------------------|------------------------------------|------------------------------------|-----------------------------------|

- c. Is this part of a Washoe County Capital Improvements Program project?

|                              |                             |
|------------------------------|-----------------------------|
| <input type="checkbox"/> Yes | <input type="checkbox"/> No |
|------------------------------|-----------------------------|

- d. If a public facility is proposed and is currently not listed in the Washoe County Capital Improvements Program or not available, please describe the funding mechanism for ensuring availability of sewer service. If a private system is proposed, please describe the system and the recommended location(s) for the proposed facility.

|  |
|--|
|  |
|--|

10. Please identify the street names and highways near the proposed amendment that will carry traffic to the regional freeway system.

|  |
|--|
|  |
|--|

11. Will the proposed amendment impact existing or planned transportation systems? (If yes, a traffic report is required.)

|                              |                             |
|------------------------------|-----------------------------|
| <input type="checkbox"/> Yes | <input type="checkbox"/> No |
|------------------------------|-----------------------------|

12. Community Services (provided name, address and distance to nearest facility).

|                         |  |
|-------------------------|--|
| a. Fire Station         |  |
| b. Health Care Facility |  |
| c. Elementary School    |  |
| d. Middle School        |  |
| e. High School          |  |
| f. Parks                |  |
| g. Library              |  |
| h. Citifare Bus Stop    |  |

## Projects of Regional Significance Information For Regulatory Zone Amendments

Nevada Revised Statutes 278.026 defines "Projects of Regional Significance". Regulatory Zone amendment requests for properties within the jurisdiction of the Truckee Meadows Regional Planning Commission (TMRPC) must respond to the following questions. A "Yes" answer to any of the following questions may result in the application being referred first to the Truckee Meadows Regional Planning Agency (TMRPA) for submission as a project of regional significance. Applicants should consult with County or Regional Planning staff if uncertain about the meaning or applicability of these questions.

1. Will the full development potential of the Regulatory Zone amendment increase employment by not less than 938 employees?

|                              |                             |
|------------------------------|-----------------------------|
| <input type="checkbox"/> Yes | <input type="checkbox"/> No |
|------------------------------|-----------------------------|

2. Will the full development potential of the Regulatory Zone amendment increase housing by 625 or more units?

|                              |                             |
|------------------------------|-----------------------------|
| <input type="checkbox"/> Yes | <input type="checkbox"/> No |
|------------------------------|-----------------------------|

3. Will the full development potential of the Regulatory Zone amendment increase hotel accommodations by 625 or more rooms?

|                              |                             |
|------------------------------|-----------------------------|
| <input type="checkbox"/> Yes | <input type="checkbox"/> No |
|------------------------------|-----------------------------|

4. Will the full development potential of the Regulatory Zone amendment increase sewage by 187,500 gallons or more per day?

|                              |                             |
|------------------------------|-----------------------------|
| <input type="checkbox"/> Yes | <input type="checkbox"/> No |
|------------------------------|-----------------------------|

5. Will the full development potential of the Regulatory Zone amendment increase water usage by 625 acre-feet or more per year?

|                              |                             |
|------------------------------|-----------------------------|
| <input type="checkbox"/> Yes | <input type="checkbox"/> No |
|------------------------------|-----------------------------|

6. Will the full development potential of the Regulatory Zone amendment increase traffic by 6,250 or more average daily trips?

|                              |                             |
|------------------------------|-----------------------------|
| <input type="checkbox"/> Yes | <input type="checkbox"/> No |
|------------------------------|-----------------------------|

7. Will the full development potential of the Regulatory Zone amendment increase the student population from kindergarten to 12<sup>th</sup> grade by 325 students or more?

|                              |                             |
|------------------------------|-----------------------------|
| <input type="checkbox"/> Yes | <input type="checkbox"/> No |
|------------------------------|-----------------------------|





# WASHOE COUNTY

## PREDEVELOPMENT WORKSHEET

**PROJECT NAME:** Thompson Family Trust

**PROJECT CONTACT:** John Krmpotic, KLS Planning & Design

**MEETING DATE:** April 14, 2021

**ADDRESS OR LOCATION OF PROJECT:**

**PROJECT APN:** 041-650-04 & 05

**REGULATORY ZONE:** General Rural

**MASTER PLAN:** Rural

**AREA PLAN:** Southwest Truckee Meadows

**REQUIREMENTS (landscaping, traffic, sprinklers, will serve letter, etc.):**

**Planning:**

- This is a long steep uphill to get to 8 parcels. You can get 2 parcels of density within the existing Master Planning and Regulatory Zoning. You need water service, sewer service, MPA, RZA, and Regional Tier change in order to get to anything denser than 1 dwelling unit per 40 acres. Not sure it's worth it for 8 parcels. See below policies:
  - Southwest Truckee Meadows Area Plan –
    - **SW 1.2** - Policy Growth Level: In order to manage the conservation of the Southwest Truckee Meadows distinctive character, future amendments to this plan which seek to intensify growth opportunities should be limited. All requests to intensify existing land uses will be carefully reviewed for their potential impact to the sustainable management of the area's natural resources, including but not limited to water and wildlife habitat. The resource management policies and procedures articulated in this plan are intended to ensure that all growth in the Southwest Truckee Meadows planning area occurs within the limits of sustainable resource management.
    - **SW 1.3** - Available regulatory zones
      - ✓ General Rural (GR – One unit per 40 acres).
      - ✓ b. Low Density Rural (LDR – One unit per 10 acres).
      - ✓ c. Medium Density Rural (MDR – One unit per 5 acres).
      - ✓ d. High Density Rural (HDR – One unit per 2.5 acres).

~~✓ e. Medium Density Suburban (MDS - Three units per 1 acre) - Limited to the areas designated MDS as of the effective date of this plan. (effectively not permissible)~~

- ✓ f. Low Density Suburban (LDS - One unit per 1 acre).
- ✓ g. Neighborhood Commercial (NC).
- ✓ h. Open Space (OS).
- ✓ Public/Semi-public Facilities (PSP).
- ✓ j. Parks and Recreation (PR)

- **SW 1.12** - Requests to intensify existing land uses in and around the West Truckee Meadows Wildland Transition Suburban Character Management Area shall be reviewed for potential impacts to the scenic value of the Fourth Street/I-80/Truckee River corridor.
  - ✓ Expect a review on this.
- **SW 2.3** - Applicants directed to obtain a variance, special use permit, tentative map, or master plan amendment shall be required to present their items to the Citizen Advisory Board (CAB) and submit a statement to staff regarding how the final proposal responds to the community input received at the CAB.
- **SW 5.5** - Review of requests to intensify hillside development shall consider the visual impacts of the development on surrounding areas.
  - ✓ Also expect all requirements of Article 424 at tentative map stage.
- **SW 20.3** - In order for the Washoe County Planning Commission to recommend approval of any amendment involving a change of land use, the following findings must be made:
  - ✓ a. The impacts of the amendment are within commonly accepted thresholds of sustainable resource management and the county's ability to manage the conservation of the area's character will not be compromised.
  - ✓ b. A feasibility study has been conducted, commissioned and paid for by the applicant, relative to municipal water, sewer and storm water that clearly identifies the improvements likely to be required to support the intensification, and those improvements have been determined to be in substantial compliance with all applicable existing facilities and resource plans for SWTM by the Department of Water Resources. The Department of Water Resources will establish and maintain the standards and methodologies for these feasibility studies.
  - ✓ c. A traffic analysis has been conducted that clearly identifies the impact to the adopted level of service within the Southwest Truckee Meadows planning area and the improvements likely to be required to maintain/achieve the adopted level of service. This finding may be waived by the Department of Public Works for projects that are determined to have minimal impacts. The Department of Public Works may request any information it deems necessary to make this determination.

- ✓ d. For amendments that propose new or intensified commercial land use, the scale of the intended use shall be shown to be community serving in nature. Casinos are not appropriate in the Southwest Truckee Meadows planning area.
- ✓ e. For residential land use intensifications, the potential increase in residential units will not exceed Washoe County's applicable policy growth level for the SWTM Area Plan, as established under Goal One.
- ✓ f. If the proposed intensification will result in a drop below the established policy level of service for transportation (as established by the Regional Transportation Commission and Washoe County) within the Southwest Truckee Meadows planning area, the necessary improvements required to maintain the established level of service are scheduled in either the Washoe County Capital Improvements Program or Regional Transportation Improvement Program within three years of approval of the intensification. For impacts to regional roads, the Washoe County Planning Commission, upon written request from the Regional Transportation Commission, may waive this finding.
- ✓ g. If roadways impacted by the proposed intensification are currently operating below adopted levels of service, the intensification will not require infrastructure improvements beyond those articulated in Washoe County and regional transportation plans AND the necessary improvements are scheduled in either the Washoe County Capital Improvements Program or Regional Transportation Improvement Program within three years of approval of the intensification.
- ✓ h. Proposed amendments shall complement the long range plans of facilities providers for transportation, water resources, schools and parks as reflected in the policy growth level established in Policy 1.2.
- ✓ i. If the proposed intensification results in existing public school facilities exceeding design capacity and compromises the Washoe County School District's ability to implement the neighborhood school philosophy for elementary facilities, then there must be a current capital improvement plan or rezoning plan in place that would enable the District to absorb the additional enrollment. The Washoe County Planning Commission, upon request of the Washoe County School Board of Trustees, may waive this finding.
- ✓ j. Any existing development in the Southwest Truckee Meadows planning area, the South Valleys planning area, the Forest planning area, or the Southeast Truckee Meadows planning area which is subject to the conditions of a special use permit will not experience undue hardship in its ability to continue to comply with the conditions of the special use permit or otherwise to continue operation of its permitted activities. "

- Land Use and Transportation Element –
  - **LUT 1.1** Washoe County will conform to the Truckee Meadows Regional Plan’s Regional Land Designations in order to direct growth to sustainable development areas based on the Character Management Areas (CMAs) outlined in the area plans
  - **LUT 3.1** - Require timely, orderly, and fiscally responsible growth that is targeted based on the Regional Land Designations outlined in Table 3.1 and Map 2 of the Truckee Meadows Regional Plan:

| <b>Tier</b>    | <b>Minimum Density</b> | <b>Maximum Density (du/ac)</b> |
|----------------|------------------------|--------------------------------|
| Mixed Use Core | 14 du/ac               | None                           |
| Tier 1         | Existing               | No Maximum                     |
| Tier 2         | No minimum             | 30du/ac                        |
| Tier 3         | No minimum             | Existing                       |
| Rural Area     | N/A                    | 1 unit per 5 acres             |

- These parcels are located in a Tier 3 Regional Land Designation. Maximum density is existing
  - You’ll need to move from Tier 3 to Tier 2 at regional to move from Rural to Rural Residential.
    - See RF 5 - in the TMRPA 2019 Regional Plan
      1. a. Proximity to Tier 2 Land –
        - a. Not adjacent to T2 land.
      2. b. Proposed density meets the requirements and does not utilize the alternative density clause found in Policy RF3
      3. c. Enhanced potential for land use diversity and a mix of housing types
        - a. Not sure there is an argument for land use diversity on 8 parcels.
      4. d. Potential for connectivity to existing or planned multimodal transportation opportunities (e.g., sidewalks, transit, complete streets, bike lanes, multi-use paths)
        - a. Not sure there will be potential connectivity to existing or planned multimodal transportation
      5. e. Proximity and availability of adequate infrastructure and facilities, or feasibility to construct and operate capacity improvements

- a. This will need to be constructed.
- 6. f. An assessment of impacts to planned land uses in higher priority Regional Land Designations
- **LUT 15.9** No development potential may be transferred from the Rural Development Area (RDA) and Development Constrained Area (DCA) as shown on maps adopted as part of the Truckee Meadows Regional Plan, nor from existing golf courses, existing parks, existing streets and railroad rights-of-way to property located within the Truckee Meadows Service Area (TMSA) as shown on maps adopted as part of the Truckee Meadows Regional Plan.
  - Effectively prohibits transferring density from development constraints areas to the developable areas. See below.
- **LUT 31.1** The Regional Plan defines the Development Constraints Area (DCA) as an overlay upon the Truckee Meadows Service Areas and the Rural Development Area.
- **LUT 31.2** The DCA consists of playas, significant water bodies, natural slopes over 30%, publicly owned open space, and properties that are deed restricted to prevent development. Constrained lands less than 1/3 acre in size will not be included in the DCA. The DCA overlay takes precedence over otherwise applicable policies describing the desired density and intensity of development within the Truckee Meadows Service Areas and the Rural Development Area
  - Note – these parcels are located in areas that have slopes greater than 15% and 30%. A large area of these parcels are within the Development Constraints Area layers adopted by regional.
  - Most of the Land Use and Transportation Policies were required for regional conformance purposes. You’d need a regional plan amendment to allow a master plan amendment.

**Building:**

- Dan Holly has reviewed this application on behalf of Building and has no comments at this time.

**Fire:**

- Meet all requirements of 2018 International Fire Code (IFC) as amended by TMFPD.
- Meet all requirements of 2018 International Wildland Urban Interface Code (IWUIC) as amended by TMFPD.
- Provide site access and turning radius as required by 2018 IFC Chapter 5 and Appendix D.
- Provide water supply and fire hydrants for Fire Flow as required by 2018 IFC.
- Automatic Sprinkler Systems will be required for all building(s) and/or facilities 5,000 square feet or greater in area.

**Water:**

- The application indicates water service is to be provided by TMWA. TMWA water infrastructure is nearby, but not immediately available. Pad elevations relative to water tanks may cause issues with providing adequate water pressure to the proposed lots. A discovery process is highly recommended to determine infrastructure needs and costs.

**Health:**

- Properties will have to meet all subdivision requirements for future development. All grading, utility, and final maps must be reviewed and approved by WCHD – EHS.

**Air Quality:**

- If grading disturbance will be greater than 1 acre then a Dust Control Permit will be required prior to breaking ground, failure to do so may result in enforcement action resulting in a Notice of Violation with associated fines.

**Engineering:**

- Developer will need to construct sewer infrastructure to these properties. A Utility Tap permit will be required for sewer service for these properties.
- Water service from TMWA will need to be acquired to serve any properties under this project.
- This project will require a grading permit and/or special use permit, depending on the amount of grading required.
- Regional Road Impact Fees (RRIF) will apply. These fees will be assessed at permit submittal and can be paid any time between Permit Issuance and Certificate of Occupancy. These fees are paid by check, or echeck. The current fee will apply at the time of payment. [Regional Road Impact Fee Program - RTC Washoe](#)
- Please provide a few days to process fees (RRIF, Utility Tap, Sewer Connection Fees, etc) prior to Certificate of Occupancy.

**NEEDS (additional meetings, hearings, SUP, permits, etc.):****Planning:**

- Regulatory Zone Amendment
- Master Plan Amendment
- Regional Land Designation change from Tier 3 to Tier 2

**Water:**

- If a subdivision map is proposed, a water will serve from TMWA will be required prior to approval and recordation of the subdivision map. If filing of Parcel Maps is possible,

then TMWA water rights dedication process will be deferred to time of the Building Permits for each lot. It is not prudent to assume TMWA service will be available or possible. If TMWA service is not feasible, then the project may have to proceed based on individual wells, and will require relinquishment of ground water rights. Based on the comments above, Washoe County will require results of a discovery by TMWA in support of the Parcel Map approval.

**Engineering:**

- A traffic study and drainage study may be required for this project.
- Stormwater Retention Basin may be required for added flows due to new impervious surfacing.

**RELEVANT CODES:**

**Planning:**

- [https://www.washoecounty.us/csd/planning\\_and\\_development/master-plan-zoning/files/planning-maps/sw\\_area\\_plan.pdf](https://www.washoecounty.us/csd/planning_and_development/master-plan-zoning/files/planning-maps/sw_area_plan.pdf)

**Fire:**

- 2018 International Fire Code as adopted and amended  
<https://codes.iccsafe.org/content/IFC2018P4>
- 2018 International Wildland-Urban Interface Code as adopted and amended.  
<https://codes.iccsafe.org/content/IWUIC2018>
- TMFPD Fire Code Amendments.  
<https://tmfpd.us/wp-content/uploads/2020/05/Ordinance-1650-WCC-Ch-60-Fire-Code-Amendments-FINAL-15APR20-Adopted-12MAY20-Effective-01JUN20.pdf>

**Water:**

- Washoe County Development Code, Article 422
- TMWA Rule 7
- NRS 533-534

**KEY CONTACTS/CONTACT INFORMATION:**

**Fire:**

- Brett Lee / Dale Way  
775.326.6000  
[blee@tmfpd.us](mailto:blee@tmfpd.us) / [dway@tmfpd.us](mailto:dway@tmfpd.us)

**Water:**

- TMWA new business and engineering staff

**Air Quality:**

- For Dust Control Permit questions call AQMD at 775-784-7200 or visit [www.OurCleanAir.com](http://www.OurCleanAir.com).

**Engineering:**

- Engineering Technical Expert of the Day (TED) – [engineering@washoecounty.us](mailto:engineering@washoecounty.us)
- Traffic questions – Mitch Fink, PE – [mfink@washoecounty.us](mailto:mfink@washoecounty.us)
- Sewer questions – Tim Simpson, PE – [tsimpson@washoecounty.us](mailto:tsimpson@washoecounty.us)
- Stormwater – Walt West, PE – [wwest@washoecounty.us](mailto:wwest@washoecounty.us)

**RESOURCES (websites, links, etc.):**

**Water:**

- TMWA.com
- water.nv.gov

**Engineering:**

- Minimum requirements for permits  
[Engineering Division Minimum Permit Submittal Requirements with Sample Site Plan.pdf \(washoecounty.us\)](#)
- Engineering's checklist for Building permits  
[Building Permit Checklist 4-6-20.pdf \(washoecounty.us\)](#)





Subject: Tentative Subdivision Map Case Number: TM16-005  
Applicant(s): Ridges at Hunter Creek LLC. and Ridges Development Inc.  
**Agenda Item Number: 9C**  
Project Summary: A 53 lot common open space subdivision on four parcels totaling 155.01 acres  
**Recommendation: Approval with Conditions**  
Prepared by: Trevor Lloyd, Senior Planner  
Planning and Development Division  
Washoe County Community Services Department  
Phone: 775.328.3620  
E-Mail: tlloyd@washoecounty.us

---

**Description**

**Tentative Map Case Number TM16-005 (The Ridges at Hunter Creek)** – Hearing, discussion, and possible action to approve the merger and re-subdivision of four parcels totaling 155.01 acres into a 53 lot common open space subdivision.

- Applicant/Owner Ridges at Hunter Creek LLC. and Ridges Development Inc.
- Location: South of Woodchuck Circle and Hunters Peak Road and West of Hawken Drive
- Assessor's Parcel Numbers: 041-671-01, 041-650-02, 041-662-12 & 41-650-03
- Parcel Size: 155.01 acres
- Master Plan Category: Suburban Residential (SR), Rural Residential (RR) and Rural(R)
- Regulatory Zone: General Rural (GR), Low Density Suburban (LDS) and High Density Rural (HDR)
- Area Plan: Southwest Truckee Meadows Area Plan
- Citizen Advisory Board: West Truckee Meadows
- Development Code: Article 408, Common Open Space Developments; Article 424, Hillside Development; and, Article 608, Tentative Subdivision Maps
- Commission District: 1 – Commissioner Berkbigler
- Section/Township/Range: Section 19 & 30, T19N, R19E, MDM, Washoe County, NV

**Staff Report Contents**

Project Description..... 1  
Tentative Subdivision Map ..... 3  
Vicinity Map ..... 4  
Site Plan ..... 5  
Project Evaluation ..... 6  
West Truckee Meadows Citizen Advisory Board (WTMCAB) ..... 8  
Southwest Truckee Meadows Area Plan Applicable Policies ..... 9  
Reviewing Agencies.....12  
Recommendation.....16  
Motion.....16  
Appeal Process.....17

---

**Exhibits Contents**

Conditions of Approval.....Exhibit A  
Citizen Advisory Board Minutes .....Exhibit B  
Engineering and Capital Projects Letter ..... Exhibit C  
Health District Letter..... Exhibit D  
Washoe County Community Services - Utilities Division Letter .....Exhibit E  
Washoe County Planning and Development – Parks Services Letter.....Exhibit F  
Nevada Division of Environment Services Letter..... Exhibit G  
Nevada Division of Water Services Letter ..... Exhibit H  
Truckee Meadows Fire Protection District Letter ..... Exhibit I  
Washoe County School District Letter..... Exhibit J  
Washoe Storey Conservation District Letter .....Exhibit K  
State Historic Preservation Office Email..... Exhibit L  
Truckee Meadows Water Authority Correspondence ..... Exhibit M  
Public Notice ..... Exhibit N

## **Tentative Subdivision Map**

The purpose of a Tentative Subdivision Map is:

1. to allow the creation of saleable lots;
2. to implement the Washoe County Master Plan, including the Area Plans, and any specific plans adopted by the County;
3. to establish reasonable standards of design and reasonable procedures for subdivision and re-subdivision in order to further the orderly layout and use of land and insure proper legal descriptions and monumenting of subdivided land; and,
4. to safeguard the public health, safety and general welfare by establishing minimum standards of design and development for any subdivision platted in the unincorporated area of Washoe County.

The purpose of the Common Open Space Development is to set forth regulations to permit variation of lot size, including density transfer subdivisions, in order to preserve or provide open space, protect natural and scenic resources, achieve a more efficient use of land, minimize road building, and encourage a sense of community.

If the Planning Commission grants an approval of the Tentative Subdivision Map, that approval is subject to Conditions of Approval. Conditions of Approval are requirements that need to be completed during different stages of the proposed project. Those stages are typically:

- Prior to recordation of a final map.
- Prior to obtaining a final inspection and/or a certificate of occupancy on a structure.
- Prior to the issuance of a business license or other permits/licenses.
- Some Conditions of Approval are referred to as “Operational Conditions.” These conditions must be continually complied with for the life of the project.

The Conditions of Approval for Tentative Subdivision Map Case Number TM16-005 are attached to this staff report and will be included with the Action Order should the Planning Commission approve the application.

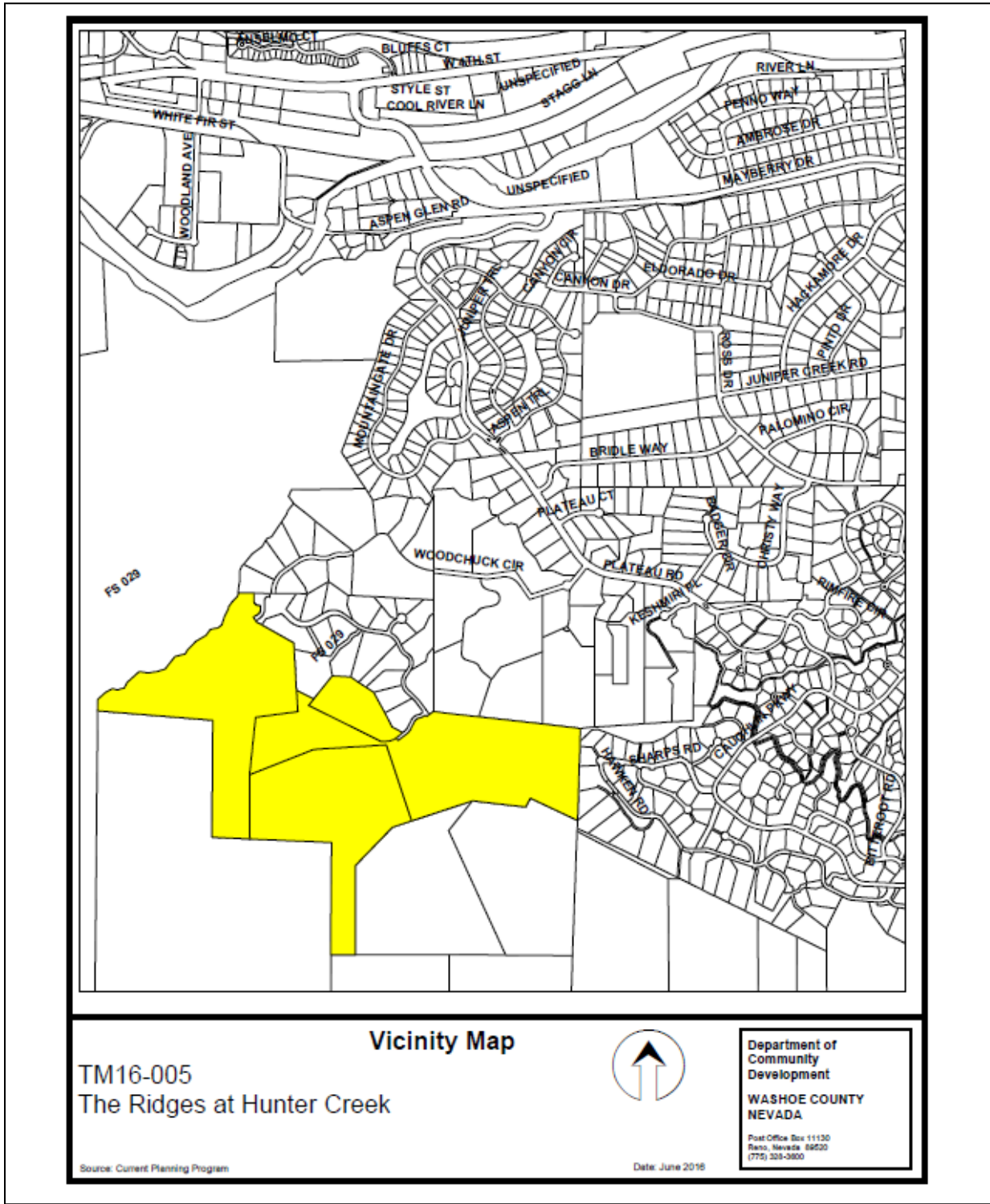

**Vicinity Map**

TM16-005  
The Ridges at Hunter Creek



Department of  
Community  
Development  
**WASHOE COUNTY  
NEVADA**

Post Office Box 11130  
Reno, Nevada 89520  
(775) 333-3800

Source: Current Planning Program Date: June 2016

Vicinity Map

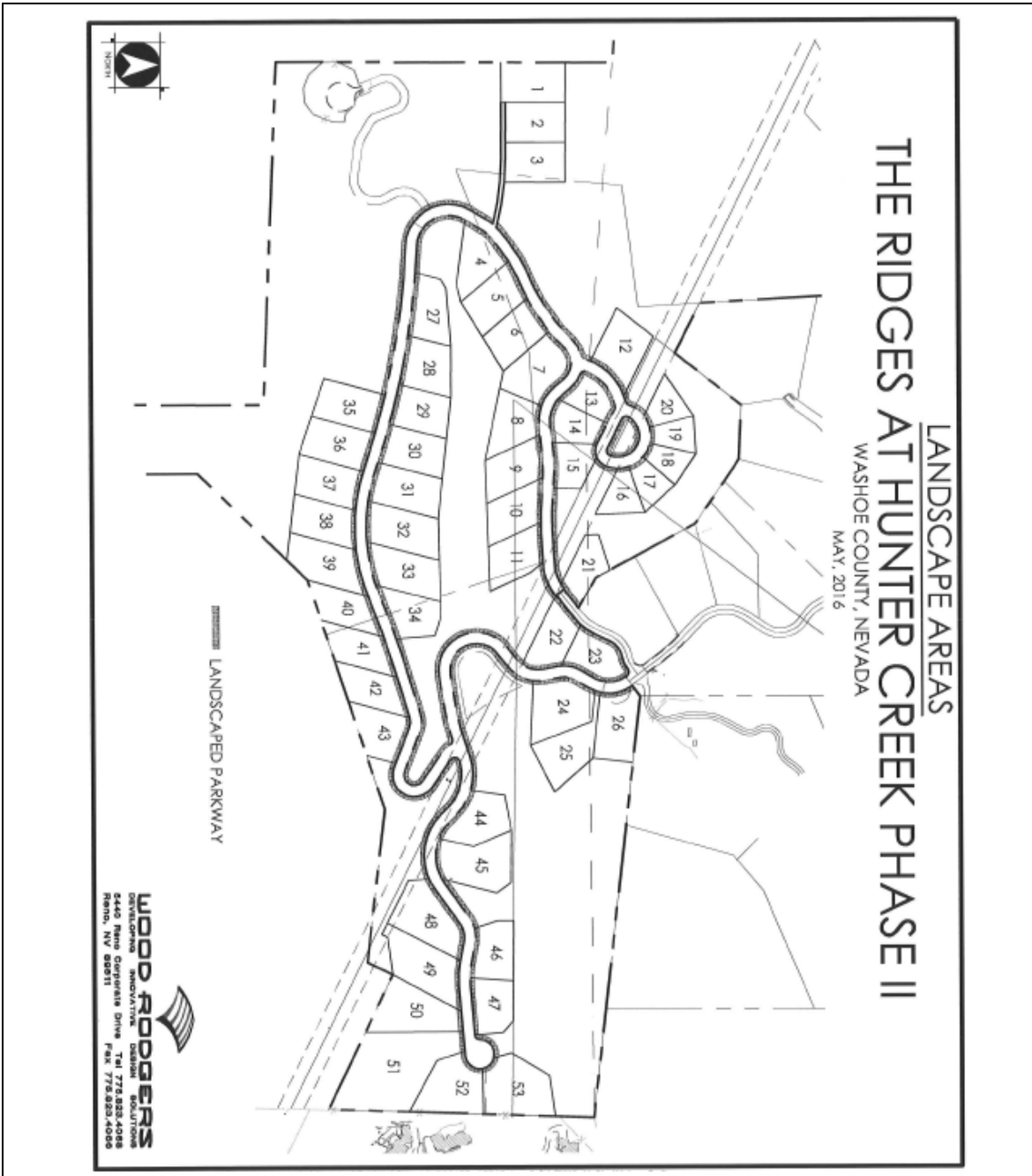

Site Plan

## **Project Evaluation**

The applicants are asking to merge four adjoining parcels totaling 155.01 acres and develop a 53 lot common open space subdivision with lots ranging in size from .37 acres to 2.3 acres. The process will involve merging all four properties into one parcel so that they may be subdivided into 53 different parcels. This process typically involves a reversion to acreage application but can be accommodated through a merger and re-subdivision tentative map application as submitted. The development is a continuation of the Ridges at Hunter Creek Phase 1 that was also a 53 lot common open space subdivision known as the Hunter Creek Development. Thirty lots in that development were recorded while the remaining 23 lots expired. The property is comprised of three different regulatory zones including Low Density Suburban (LDS), High Density Rural (HDR) and General Rural (GR).

In January 2016, a master plan amendment and regulatory zone amendment were approved which resulted in the current master plan categories and regulatory zoning on the property allowing for the 53 unit density. The project will be a common open space development, allowing for the clustering of lots and retaining most of the property as open space in its natural state. Although there are several regulatory zones throughout the property, the lots sizes will be consistent with the Low Density Suburban (LDS) regulatory zone. Therefore, the applicants are requesting standard LDS setbacks of 30 feet from the front and rear property lines and 12 feet from the side property lines.

The property will be gated and all roadways will be private; however, pedestrian access through the property including to and from the Michael D. Thompson trailhead will be available via the existing and planned roads and trails within the development. Formal landscaping, similar to the existing landscaping within phase 1 of the Ridges at Hunter Creek, will be provided along the roadways. Disturbed open space will be revegetated with native vegetation, and undisturbed open space will remain in its native state. Staff will require the applicant to submit a weed control plan prior to the recordation of the first final map. All landscaping maintenance and weed control will be the responsibility of the homeowners association.

Energy conservation will result from the infill condition of the project site. Also, most of the lots are oriented in a north/south direction which will result in solar benefits. There is no perimeter fencing proposed; however, residential fencing will consist of open view designs and will be consistent in all side and rear yard locations abutting common open space in accordance with the CC&Rs.

## **Traffic**

Access to the Ridges at Hunter Creek is south from Mayberry Drive on Plateau Road to Woodchuck Circle. The primary access point to the project begins at the current terminus of Woodchuck Circle which is gated.

The potential traffic impacts resulting from the proposed development were analyzed by staff, and it was determined that the immediate roadways that serve the site will maintain acceptable levels of service (LOS). The three roads that will be directly impacted by the proposed density increase are Woodchuck Road, Plateau Road and Mayberry Drive. Each of these roadways are currently operating well below the level of service, and the potential increase of traffic generated from 53 residential lots will not substantially impact these roadways.

An emergency access gate that connects to an emergency access road providing access to Caughlin Parkway is also located at the easterly end of the site. The current project site includes 154.99 acres of property, part of which was included in the previous tentative subdivision map (63.46 acres) and part of which was not (91.53 acres). A water tank was constructed near the southwesterly corner of APN 041-650-02 to serve the development.

### **Washoe County School District**

The proposed development is zoned for Caughlin Ranch Elementary School, Swope Middle School and Reno High School. All three of these schools are currently under capacity. According to the Washoe County School District, the 53 proposed units would generate approximately 14 students which represent a minimal impact. Caughlin Ranch Elementary School has a base capacity of 606 students with an enrollment for the 2015-2016 school year of 560 students; Swope Middle School has a base capacity of 853 students with an enrollment for the 2015-2016 school year of 733 students; and Reno High School has a base capacity of 1965 students with an enrollment for the 2015-2016 school year of 1703 students (Refer to Exhibit J – Washoe County School District Letter).

Although these schools are currently under capacity, many of the schools in Washoe County are over capacity. On September 22, 2015, the Washoe County School District Board of Trustees set 120% of capacity as the conversion threshold for elementary schools to be converted to a multi-track year round calendar, which increases effective capacity of a school by approximately 25%. This policy will go into effect as of the 2017-2018 school year. The Washoe County School District has asked for a condition requiring the development to provide a disclosure to each homebuyer on their closing documents that K-12 students in this subdivision may be assigned to the nearest WCSD school(s) with available capacity in the event that the zoned schools cannot accommodate additional students.

### **Site Characteristics**

The subject property borders the northwesterly portion of the site where no development is proposed. A drainageway runs through the central portion of the site, and culverts and basin area improvements have already been installed. The topography of the site is varied and includes steep, moderate and flat terrain. The site is characterized by native vegetation (primarily native shrubs, sagebrush and grasses punctuated by juniper and pinion pine trees) and includes evidence of grading, trails and dirt road use. The Washoe County Michael D. Thompson trailhead is located on the property near the northwesterly portion of the site and includes parking and restroom facilities. Washoe County maps from the Conservation Element show this property to be within Black Bear and Mule Deer habitat. There are no significant ridgelines on the property. The property is in an overall general area that is subject to wildfire hazards. A 120kv Electrical Transmission line bisects the property from east to west; no buildings shall be allowed within the powerline easement or within 10 feet of either side of the easement. There is an existing water tank located at the western edge of the property that will serve the development.

### **Significant Hydrologic Resources**

Hunter Creek, which is a Significant Hydrologic Resource as defined by Article 418 of the Development Code, runs along the northern boundary of the subject property. Article 418 substantially limits the type and intensity of development within the Critical and Sensitive Stream Zone Buffers from Hunter Creek. All developments associated with the proposed tentative map

are located a significant distance away from the critical and sensitive stream zones for Hunter Creek.

### **Hillside Development Standards**

Article 424 of the Development Code regulates all new development with slopes 15% or greater over 20% of the subject site. The proposed development exceeds these criteria and is therefore subject to the Hillside Development standards. The applicant has complied with the standards of Article 424, Hillside Development, including the submittal of the slope analysis and the identification of the building pads on each parcel as shown on the grading plans. The applicant is proposing custom homes on each lot that will make use of hillside adaptive design. Any grading that exceeds the thresholds identified in the development code may require the separate approval of a special use permit.

Most of the grading for roadways, drainage and infrastructure has already taken place with phase 1 of the Ridges at Hunter Creek subdivision; however, some additional grading will be needed to complete the remainder of the project. It is anticipated that approximately 30 thousand cubic yards of new grading will take place. The development has been designed to balance all grading on site with no import or export necessary. Where needed, grading will be minimal and will work with the natural contours of the land. Slopes will be limited to 3:1 (3 foot horizontal to 1 foot vertical) cut and fill slopes except where exempted in Article 438, Grading Standards. Any other cuts or fill slopes that are required to be steeper than 3:1 slope will require the use of retaining walls which will be consistent with the retaining walls constructed with the first phase of the development.

### **Water and Sewer**

Sewer service will be provided by Washoe County and water service will be provided by the Truckee Meadows Water Authority (TMWA). TMWA has conducted an initial discovery of the project (see Exhibit M) and expressed that they are agreeable to serve the project if the required construction and dedication of necessary infrastructure and easements are provided. Utilities (water and sewer) are stubbed to the property and a TMWA water tank has been constructed on site to serve the development.

### **West Truckee Meadows Citizen Advisory Board (WTMCAB)**

The proposed project was presented by the applicant's representative at the West Truckee Meadows Citizen Advisory Board meeting on June 13, 2016. The CAB unanimously recommended their support for the proposed project. The attached CAB minutes reflect discussion on the project item (see Exhibit B).

In addition to the West Truckee Meadows CAB meeting, the applicants scheduled a meeting and noticed the immediate neighbors. The meeting took place on April 25<sup>th</sup> and the noticing matched the noticing for the Planning Commission meeting. The meeting was lightly attended and no significant issues or concerns were raised although some mentioned they would prefer to see the property remain as open space.



## **Southwest Truckee Meadows Area Plan - Policies**

**Goal Two: Common Development Standards in the Southwest Truckee Meadows Planning Area. Establish development guidelines that will implement and preserve the community character commonly found within the Southwest Truckee Meadows planning area.**

SW.2.1 When feasible, given utility access constraints, grading for residential purposes after the date of final adoption of this plan will:

- a. Minimize disruption to natural topography.
- b. Utilize natural contours and slopes.
- c. Complement the natural characteristics of the landscape.
- d. Preserve existing vegetation and ground coverage to minimize erosion.
- e. Minimize cuts and fills.

*Staff Response: The development as proposed will utilize natural contours and slopes to the best extent possible. No mass grading is proposed and most of the roadway grading has already taken place.*

SW.2.2 Site development plans in the Southwest Truckee Meadows planning area must include a plan for the control of noxious weeds. The plan should be developed through consultation with the Washoe County District Health Department, the University of Nevada Cooperative Extension, and/or the Washoe-Storey Conservation District on a voluntary compliance basis.

*Staff Response: Staff has included a condition requiring the submittal of a plan for the control of noxious weeds.*

SW.2.3 Applicants directed to obtain a variance, special use permit, tentative map, or master plan amendment shall be required to present their items to the Citizen Advisory Board (CAB) and submit a statement to staff regarding how the final proposal responds to the community input received at the CAB.

*Staff Response: The applicants attended the June 13, 2016 West Truckee Meadows Citizen Advisory Board. A copy of their statement responding to the CAB comments shall be provided to the Planning Commission prior to the July 5, 2016 meeting.*

SW.2.4 During review of tentative maps and other development proposals, the Planning Commission will review the adequacy of the minimum standards established under Goal 2; and upon a finding that a standard is inadequate to implement these goals, may impose other similar standards as necessary to implement the relevant goal. Said similar standards may include but are not limited to, perimeter parcel matching and alternative construction materials.

*Staff Response: No such finding is necessary to address standards established under Goal 2.*

SW.2.7 Whenever feasible, new homes should be located in a manner that facilitates the immediate use of, or future conversion to, renewable energy technologies. This includes home orientation to solar and wind exposure and geothermal resources.

*Staff Response: All new homes shall be custom built homes. Additionally, the homes will be oriented in such a way to take advantage of passive/natural heating and cooling opportunities*

SW.2.9 Prior to their incorporation into the Development Code, the standards established in policies SW.2.1-SW.2.14 will be implemented through tentative map conditions, improvements plans, CC&Rs, deed restrictions, or other methods deemed as appropriate by the Director of Community Development. When appropriate, Washoe County staff shall establish the implementation measures as conditions of tentative map approval.

*Staff Response: These standards have been conditioned with the adoption of the CC&R's.*

SW.2.10 The impact of development on adjacent land uses will be mitigated. The appropriate form of mitigation should be determined through a process of community consultation and cooperation. Applicants should be prepared to demonstrate how the project conforms to this policy.

*Staff Response: Impacts to the adjacent land uses have been taken into consideration with the design of the proposed subdivision. Additionally, the three lots (lots 51, 52 & 53) located along the eastern edge of the property are in substantial conformance with the size and depth of the adjoining properties within the Eagles Nest subdivision.*

SW.2.11 Development activities should be designed to support the efficient use of infrastructure, and the conservation of recharge areas, habitat, and open vistas.

*Staff Response: The design of the development leaves a good deal of open space for habitat and recharge areas, also there are no significant ridgelines that we be disturbed with the development of the site. This development is essentially an infill project with much of the infrastructure already in place.*

SW.2.15 Clustering of density to facilitate the efficient use of infrastructure and maintenance of habitat and open space is appropriate. Land owners who seek to create new parcels but choose not to cluster should be able to demonstrate how habitat, recharge areas, and open space will be preserved.

*Staff Response: The development will involve the clustering of the lots, with lots ranging in size from .37 acres to 2.3 acres and retain a large amount of acreage in open space.*

**Goal Four: Resources key to the preservation and implementation of the character described in the Character Statement will be protected and, where possible, enhanced.**

SW.4.1 Washoe County will continue to pursue opportunities for the public acquisition of lands in the planning area that contain key resources necessary for the long term preservation and enhancement of the area's character.

*Staff Response: Parks staff has requested a relocatable easement for the possible establishment and development of a future trail through the open space of the development.*

**Goal Five: Maintain open vistas and minimize the visual impact of hillside development in a manner that implements the community character described above.**

SW.5.1 With the exception of temporary infrastructure for construction projects, Washoe County will require the underground placement of new utility distribution infrastructure within the SWTM Management Area. Utility transmission facilities shall require a special use permit. In considering whether to grant a special use permit, or in consideration of any conditions, including underground placement, which may be placed upon an approval, the Planning Commission will utilize the best available information, including but not limited to the most recent Regional Utility Corridor Report, and any Environmental Impact Statement or other study undertaken regarding the proposal.

*Staff Response: All new distribution lines will be placed underground; additionally, existing distributions lines will be placed underground as well.*

SW.5.2 The Washoe County Departments of Community Development and Public Works will establish and oversee compliance with design standards for grading that minimize the visual impact of all residential and non-residential hillside development, including road cuts and driveways.

*Staff Response: The design of the subdivision will minimize the amount of grading throughout the development. Washoe County Planning and Development and Engineering and Capital Projects will ensure compliance with all grading standards established in Article 438, Grading Standards.*

SW.5.3 The grading design standards referred to in Policy SW.5.2 will, at a minimum, ensure that disturbed areas shall be finished and fill slopes will not exceed a 3:1 slope, and that hillside grading will establish an undulating naturalistic appearance by creating varying curvilinear contours.

*Staff Response: Very little grading is anticipated with this design, most of the roadways and drainage areas have already been completed; additionally, the lots will be custom lots, so no mass grading is anticipated. Where new grading is needed, the cut and fill slopes will not exceed a 3:1 slope except in limited locations where exempted by code.*

SW.5.4 When necessary to mitigate the impact of road cuts, driveways and similar features on prominent hillsides, staff may require the installation of landscaping that will significantly soften the visual impact within three years of installation. Maintenance plans for these landscaped areas may be required.

*Staff Response: The applicants intend to design the new phase similar to the phase one of this development with formal landscaping along the roadways. Staff shall condition a 3 year maintenance plan for these landscaped areas.*

SW.5.5 Review of requests to intensify hillside development shall consider the visual impacts of the development on surrounding areas.

*Staff Response: The development has been designed to work with the natural contours of the property and limits develop to the flat areas of the property in keeping with the surrounding developments.*

**Goal Seven: Public and private development will respect the value of cultural and historic resources in the community.**

- SW.7.1 Prior to the approval of master plan amendments, tentative maps, or public-initiated capital improvements in the Southwest Truckee Meadows planning area, the Nevada Department of Conservation and Natural Resources will be contacted and, if the department requests, an appropriate archaeological investigation will be conducted.

*Staff Response: The application was submitted to the Nevada Division of Environmental Protection, the Division of Water Resources and the State Historic Preservation Office (SHPO) all of which are divisions within the Nevada Dept. of Conservation and Natural Resources. Furthermore, the SHPO received a complete archaeological inventory titled the "Archaeological Inventory of Approximately 140 Acres for the Hunter Creek trails Project, Reno, Washoe County (WCRM Report No. 05-R-67)(Lennon, 2005)". According to SHPO, the two regionally significant resources, the Hunter Creek Ditch and the Steamboat Ditch, do not appear to be in the project area and will not likely be adversely affected by the project.*

- SW.12.1 Prior to the approval of master plan amendments, tentative maps, public initiated capital improvements or any project impacting 10 or more acres in the Southwest Truckee Meadows Planning area, the Nevada Department of Wildlife will be contacted and given an opportunity to provide conservation, or other wildlife and habitat management input to the project.

*Staff Response: The application was submitted to the Nevada Department of Wildlife (NDOW). A representative from NDOW attended the agency review meeting on June 10, 2016 and they provided a letter addressing concerns relating to wildlife, migration routes and habitat management, etc. Staff requested from NDOW an amended letter providing clear conditions to address their concerns. It is anticipated that Washoe County will obtain a revised letter with conditions prior to the July 5, 2016 Planning Commission hearing.*

- SW.19.1 Tentative subdivision maps will not be approved for any development until the infrastructure and resource needs of that development have been evaluated by the Department of Water Resources and found consistent with all applicable water and wastewater resources and facilities plans.

*Staff Response: The application was evaluated by Washoe County Utilities and the Truckee Meadows Water Authority and found to be consistent with all applicable water and wastewater resources and facilities plan.*

**Reviewing Agencies**

The following agencies received a copy of the project application for review and evaluation.

- Washoe County Community Services Department
  - Engineering and Capital Projects
  - Planning and Development
  - Regional Parks and Open Space
  - Traffic
  - Utilities (Sewer)

- Nevada Division of Environmental Protection
- Nevada Department of Water Resources
- Nevada Department of Wildlife
- Truckee Meadows Fire Protection District
- Truckee Meadows Regional Planning Agency
- Reno Community Development Department
- Regional Transportation Commission
- Washoe County Health District
- Washoe County School District
- Washoe-Storey Conservation District
- NV Energy
- Truckee Meadows Water Authority
- Nevada State Historic Preservation Office

Twelve of the seventeen above-listed agencies/departments submitted a response to the proposed tentative subdivision map. A summary of each agency's comments and/or recommended conditions of approval and their contact information are provided. The Conditions of Approval document is attached to this staff report and will be included with the Action Order should the Planning Commission approve the tentative subdivision map application.

- Washoe County Planning and Development addressed the project density, setbacks, landscaping, etc.  
Contact: Trevor Lloyd, 328-3620, [tlloyd@washoecounty.us](mailto:tlloyd@washoecounty.us)
- Washoe County Engineering and Capital Projects addressed grading, drainage, stormwater management, maintenance of common area, easements, *traffic*, etc.  
Contact: Walt West, 328-2310, [wwest@washoecounty.us](mailto:wwest@washoecounty.us)
- Washoe County Health District addressed water system requirements, catch basin and detention basin design, rockery wall design, roadside ditch design, etc.  
Contact: James English, 328-2434, [jenglish@washoecounty.us](mailto:jenglish@washoecounty.us)  
JL Shaffer, 785-4599, [jshaffer@washoecounty.us](mailto:jshaffer@washoecounty.us)
- Nevada Division of Environmental Protection requires the submittal of a construction stormwater permit.  
Contact: Alexis Perkins, 687-4670
- Washoe County Planning and Development – Parks and Open Space addressed the expansion of the existing easement near/along the Hunter Creek trail and the establishment of a relocatable trail easement for possible future trail on the property.  
Contact: Dennis Troy, 328-2059, [dtroy@washoecounty.us](mailto:dtroy@washoecounty.us)
- Truckee Meadows Fire Protection District stated that the development shall meet all requirements of Washoe County Code 60, including International Wildland Urban Interface and the International Fire Code, vegetation management, CC&R requirements, etc.

Contact: Amy Ray, 326-6000, [aray@fmfpd.us](mailto:aray@fmfpd.us)

- State Historic Preservation Office reviewed the archaeological inventory and stated that the two regionally significant resources on site will not likely be adversely affected by the project.

Contact: Rebecca Palmer, 775.684.3443, [rlpalmer@shpo.nv.gov](mailto:rlpalmer@shpo.nv.gov)

- Washoe County Utility Services Division requires improvement plans for construction of sanitary sewer collection system(s), sanitary sewer report, fees, easements, etc.

Contact: Tim Simpson, 775.954.4648, [tsimpson@washoecounty.us](mailto:tsimpson@washoecounty.us)

- Nevada Division of Water Resources stated that water rights are required. A will serve letter from TMWA will be required, etc.

Contact: Steve Shell, 775.684.2836, [sshell@water.nv.gov](mailto:sshell@water.nv.gov)

- Washoe Storey Conservation District recommended that a jurisdictional determination of wetlands along Hunter Creek.

Contact: Kevin J. Roukey 775.232.1571, [kevinjr\\_51@att.net](mailto:kevinjr_51@att.net)

- Washoe County School District asks for a condition for a disclosure to all future homebuyer that students may be assigned to nearest school(s).

Contact: Kevin J. Roukey 775.232.1571, [kevinjr\\_51@att.net](mailto:kevinjr_51@att.net)

### **Staff Comment on Required Findings**

WCC Section 110.608.25 requires that all of the following findings be made to the satisfaction of the Washoe County Planning Commission before granting approval of the tentative subdivision map request. Staff has completed an analysis of the application and has determined that the proposal is in compliance with the required findings as follows.

- 1) Plan Consistency. That the proposed map is consistent with the Master Plan and any specific plan.

*Staff Comment: The proposed tentative map is consistent with the goals and policies of the Master Plan and the Southwest Truckee Meadows Area Plan.*

- 2) Design or Improvement. That the design or improvement of the proposed subdivision is consistent with the Master Plan and any specific plan.

*Staff Comment: The proposed tentative map meets all of the density, lot size and common open space criteria of the Master Plan and the Southwest Truckee Meadows Area Plan. The proposed development meets the allowable density of 53 units allowed in Low Density Suburban (LDS), High Density Rural (HDR) and General Rural (GR) regulatory zones.*

- 3) Type of Development. That the site is physically suited for the type of development proposed.

*Staff Comment: The site is physically suited for the type of development proposed. The natural characteristics of the site can accommodate the type of development proposed.*

- 4) Availability of Services. That the subdivision will meet the requirements of Article 702, Adequate Public Facilities Management System.

*Staff Comment: The Truckee Meadows Water Authority will provide water and Washoe County will provide sewer service. The Truckee Meadows Fire Protection District has indicated that they can adequately provide emergency services. There are adequate services available to serve the proposed development.*

- 5) Fish or Wildlife. That neither the design of the subdivision nor any proposed improvements is likely to cause substantial environmental damage, or substantial and avoidable injury to any endangered plant, wildlife or their habitat.

*Staff Comment: The proposed improvements will not cause substantial environmental damage or harm to endangered plants, wildlife or their habitat.*

- 6) Public Health. That the design of the subdivision or type of improvement is not likely to cause significant public health problems.

*Staff Comment: Due to the location and design of the subdivision and type of improvements, this development is not likely to cause significant public health problems.*

- 7) Easements. That the design of the subdivision or the type of improvements will not conflict with easements acquired by the public at large for access through, or use of property within, the proposed subdivision.

*Staff Comment: The proposed development has taken all easements into consideration and will not conflict with the easements in regards to utility purposes or public access, etc.*

- 8) Access. That the design of the subdivision provides any necessary access to surrounding, adjacent lands and provides appropriate secondary access for emergency vehicles.

*Staff Comment: The design of the subdivision provides access to surrounding adjacent lands and provides appropriate secondary access for emergency vehicles.*

- 9) Dedications. That any land or improvements to be dedicated to the County is consistent with the Master Plan.

*Staff Comment: In the event that the roads or other lands are dedicated to the County, the lands will be improved such that they are consistent with the Master Plan and/or built to County standards.*

- 10) Energy. That the design of the subdivision provides, to the extent feasible, for future passive or natural heating or cooling opportunities in the subdivision.

*Staff Comment: To the extent feasible, the development will include building materials to allow for passive or natural heating and cooling opportunities. Additionally, the homes*

*will be oriented in such a way to take advantage of passive/natural heating and cooling opportunities.*

### **Recommendation**

Those agencies which reviewed the application recommended conditions in support of approval of the project. Therefore, after a thorough analysis and review, Tentative Subdivision Map Case Number TM16-005 is being recommended for approval with conditions. Staff offers the following motion for the Planning Commission's consideration.

### **Motion**

I move that after giving reasoned consideration to the information contained in the staff report and information received during the public hearing, the Washoe County Planning Commission approve Tentative Subdivision Map Case Number TM16-005 for The Ridges at Hunter Creek Phase II with the conditions of approval included as Exhibit A in the staff report for this item, having made all ten findings in accordance with Washoe County Development Code Section 110.608.25:

- 1) Plan Consistency. That the proposed map is consistent with the Master Plan and any specific plan;
- 2) Design or Improvement. That the design or improvement of the proposed subdivision is consistent with the Master Plan and any specific plan;
- 3) Type of Development. That the site is physically suited for the type of development proposed;
- 4) Availability of Services. That the subdivision will meet the requirements of Article 702, Adequate Public Facilities Management System;
- 5) Fish or Wildlife. That neither the design of the subdivision nor any proposed improvements is likely to cause substantial environmental damage, or substantial and avoidable injury to any endangered plant, wildlife or their habitat;
- 6) Public Health. That the design of the subdivision or type of improvement is not likely to cause significant public health problems;
- 7) Easements. That the design of the subdivision or the type of improvements will not conflict with easements acquired by the public at large for access through, or use of property within, the proposed subdivision;
- 8) Access. That the design of the subdivision provides any necessary access to surrounding, adjacent lands and provides appropriate secondary access for emergency vehicles;
- 9) Dedications. That any land or improvements to be dedicated to the County is consistent with the Master Plan; and
- 10) Energy. That the design of the subdivision provides, to the extent feasible, for future passive or natural heating or cooling opportunities in the subdivision.



## **Appeal Process**

Planning Commission action will be effective 10 calendar days after the written decision is filed with the Secretary to the Planning Commission and mailed to the original applicant, unless the action is appealed to the Washoe County Board of County Commissioners, in which case the outcome of the appeal shall be determined by the Washoe County Board of County Commissioners. Any appeal must be filed in writing with the Planning and Development Division within 10 calendar days after the written decision is filed with the Secretary to the Planning Commission and mailed to the original applicant.

xc: Applicant/Owner: Ridges at Hunter Creek LLC and Ridges Development Inc. Attn: Ranson Webster, 4345 Eagle Valley Circle, Reno, NV 89519

Representatives: Wood Rodgers, Inc. Attn: Melissa Lindell, 5440 Reno Corporate Drive, Reno, NV 89511

Other Contact: Wood Rodgers, Inc. Attn: Steve Strickland, 5440 Reno Corporate Drive, Reno, NV 89511

# EXHIBIT A

## Conditions of Approval

Tentative Subdivision Map Case Number TM16-005

The project approved under Tentative Subdivision Map Case Number TM16-005 shall be carried out in accordance with the Conditions of Approval granted by the Planning Commission on July 5, 2016. Conditions of Approval are requirements placed on a permit or development by each reviewing agency. These Conditions of Approval may require submittal of documents, applications, fees, inspections, amendments to plans, and more. These conditions do not relieve the applicant of the obligation to obtain any other approvals and licenses from relevant authorities required under any other act or to abide by all other generally applicable Codes, and neither these conditions nor the approval by the County of this project/use override or negate any other applicable restrictions on uses or development on the property.

**Unless otherwise specified**, all conditions related to the approval of this Tentative Subdivision Map shall be met or financial assurance must be provided to satisfy the conditions of approval prior to issuance of a grading or building permit. The agency responsible for determining compliance with a specific condition shall determine whether the condition must be fully completed or whether the applicant shall be offered the option of providing financial assurance. All agreements, easements, or other documentation required by these conditions shall have a copy filed with the County Engineer and the Planning and Development Division.

Compliance with the conditions of approval related to this Tentative Subdivision Map is the responsibility of the applicant, his/her successor in interest, and all owners, assignees, and occupants of the property and their successors in interest. Failure to comply with any of the conditions imposed in the approval of the Tentative Subdivision Map may result in the initiation of revocation procedures.

Washoe County reserves the right to review and revise the conditions of approval related to this Tentative Subdivision Map should it be determined that a subsequent license or permit issued by Washoe County violates the intent of this approval.

For the purpose of conditions imposed by Washoe County, “may” is permissive and “shall” or “must” is mandatory.

Conditions of Approval are usually complied with at different stages of the proposed project. Those stages are typically:

- Prior to recordation of a final map.
- Prior to obtaining a final inspection and/or a certificate of occupancy.
- Prior to the issuance of a business license or other permits/licenses.
- Some “Conditions of Approval” are referred to as “Operational Conditions.” These conditions must be continually complied with for the life of the project.

**The Washoe County Commission oversees many of the reviewing agencies/departments with the exception of the following agencies.**

- **The DISTRICT BOARD OF HEALTH, through the Washoe County Health District, has jurisdiction over all public health matters in the Health District.**

**Any conditions set by the Health District must be appealed to the District Board of Health.**

- **The WASHOE COUNTY SCHOOL DISTRICT is directed and governed by its own Board. Therefore, any conditions set by the Washoe County School District must be appealed to their School Board.**

|                                                                                                                               |
|-------------------------------------------------------------------------------------------------------------------------------|
| <p style="text-align: center;"><b>STANDARD CONSIDERATIONS FOR SUBDIVISIONS</b><br/><b>Nevada Revised Statutes 278.349</b></p> |
|-------------------------------------------------------------------------------------------------------------------------------|

Pursuant to NRS 278.349, when contemplating action on a Tentative Subdivision Map, the governing body or the Planning Commission, if it is authorized to take final action on a tentative map, shall consider:

- (a) Environmental and health laws and regulations concerning water and air pollution, the disposal of solid waste, facilities to supply water, community or public sewage disposal and, where applicable, individual systems for sewage disposal;
- (b) The availability of water which meets applicable health standards and is sufficient for the reasonably foreseeable needs of the subdivision;
- (c) The availability and accessibility of utilities;
- (d) The availability and accessibility of public services such as schools, police and fire protection, transportation, recreation and parks;
- (e) Conformity with the zoning ordinances and master plan, except that if any existing zoning ordinance is inconsistent with the master plan, the zoning ordinance takes precedence;
- (f) General conformity with the governing body's master plan of streets and highways;
- (g) The effect of the proposed subdivision on existing public streets and the need for new streets and highways to serve the subdivision;
- (h) Physical characteristics of the land such as floodplain, slope and soil;
- (i) The recommendations and comments of those entities reviewing the tentative map pursuant to NRS 278.330 and 278.335; and
- (j) The availability and accessibility of fire protection, including, but not limited to, the availability and accessibility of water and services for the prevention and containment of fires, including fires in wild lands.

FOLLOWING ARE CONDITIONS OF APPROVAL REQUIRED BY THE REVIEWING AGENCIES. EACH CONDITION MUST BE MET TO THE SATISFACTION OF THE ISSUING AGENCY.

**Washoe County Planning and Development Division**

1. The following conditions are requirements of the Planning and Development Division, which shall be responsible for determining compliance with these conditions.

**Contact Name** – Trevor Lloyd, 775.328.3620

- a. The applicant shall demonstrate substantial conformance to the plans approved as part of this special use permit.
- b. The tentative map shall be in substantial compliance with the Approved Tentative Map and provisions of Washoe County Development Code Article 608, Common Open Space Development, and Article 608, Tentative Subdivision Maps.

| <b>Regulatory Zone<br/>for Review Purposes</b> | <b>General Rural (GR)<br/>Low Density Suburban (LDS)<br/>High Density Rural (HDR)</b> |
|------------------------------------------------|---------------------------------------------------------------------------------------|
| Minimum Lot Area Proposed                      | Common Open Space Development                                                         |
| Minimum Lot Width                              | Common Open Space Development                                                         |
| Minimum Front Yard                             | 30 feet                                                                               |
| Minimum Side Yard                              | 12 feet                                                                               |
| Minimum Rear Yard                              | 30 feet                                                                               |
| Maximum Building Height                        | 35 feet                                                                               |

Notes: Variances to these standards may be processed per Washoe County Code.

- c. The subdivision shall be in substantial conformance with the provisions of Washoe County Development Code Article 604, Design Requirements, and Article 608, Tentative Subdivision Maps.
- d. Final maps and final construction drawings shall comply with all applicable statutes, ordinances, rules, regulations and policies in effect at the time of submittal of the tentative map or, if requested by the developer and approved by the applicable agency, those in effect at the time of approval of the final map.
- e. The subdivider shall present to Washoe County a final map, prepared in accordance with the tentative map, for the entire area for which a tentative map has been approved, or one of a series of final maps, each covering a portion of the approved tentative map, within four years after the date of approval of the tentative map or within two years of the date of approval for subsequent final maps. On subsequent final maps, that date may be extended by two years if the extension request is received prior to the expiration date.
- f. Final maps shall be in substantial compliance with all plans and documents submitted with and made part of this tentative map request, as may be amended by action of the final approving authority.
- g. All final maps shall contain the applicable portions of the following Jurat:

The Tentative Map for TM16-005 (The Ridges at Hunter Creek)  
was APPROVED BY THE WASHOE COUNTY PLANNING  
COMMISSION ON JULY 5, 2016.

THIS FINAL MAP, MAP NAME AND UNIT/PHASE #, MEETS ALL APPLICABLE STATUTES, ORDINANCES AND CODE PROVISIONS, IS IN SUBSTANTIAL CONFORMANCE WITH THE TENTATIVE MAP AND ITS CONDITIONS, WHICH ARE INCORPORATED HEREIN BY THIS REFERENCE, AND THOSE CONDITIONS HAVE BEEN SATISFIED FOR RECORDATION OF THIS MAP, EXCEPT THAT THE "OPERATIONAL CONDITIONS" CONTAINED IN THE RECORDED ACTION ORDER SHALL REMAIN IN FULL FORCE AND EFFECT IN PERPETUITY.

IF ALL LOTS ON THIS MAP ARE REVERTED TO ACREAGE AND A NEW SUBDIVISION APPROVAL IS OBTAINED AT A FUTURE DATE, THE PROVISIONS OF THIS APPROVAL SHALL BE NULL AND VOID, UPON APPROVAL BY WASHOE COUNTY OF THOSE ACTIONS.

[Omit the following paragraph if this is the first and last (only) final map.]

THE FIRST FINAL MAP FOR THIS TENTATIVE MAP WAS APPROVED AND ACCEPTED FOR RECORDATION ON date of Planning and Development Director's signature on first final map. THE MOST RECENTLY RECORDED FINAL MAP WAS APPROVED AND ACCEPTED FOR RECORDATION ON date of Planning and Development Director's signature on most recent final map. (If an extension has been granted after that date – add the following): A TWO YEAR EXTENSION OF TIME FOR THE TENTATIVE MAP WAS APPROVED BY THE WASHOE CO9UNTY PLANNING COMMISSION ON \_\_\_\_\_.

THE NEXT FINAL MAP FOR <TM CASE NUMBER> MUST BE APPROVED AND ACCEPTED FOR RECORDATION BY THE PLANNING AND DEVELOPMENT DIRECTOR ON OR BEFORE THE EXPIRATION DATE, THE \_\_\_\_ DAY OF \_\_\_\_\_, 20\_\_\_\_, OR AN EXTENSION OF TIME FOR THE TENTATIVE MAP MUST BE APPROVED BY THE WASHOE COUNTY PLANNING COMMISSION ON OR BEFORE SAID DATE.

THIS FINAL MAP IS APPROVED AND ACCEPTED FOR RECORDATION THIS \_\_\_\_ DAY OF \_\_\_\_\_, 20\_\_\_\_ BY THE PLANNING AND DEVELOPMENT DIRECTOR. THE OFFER OF DEDICATION FOR STREETS, SEWERS, ETC. IS REJECTED AT THIS TIME, BUT WILL REMAIN OPEN IN ACCORDANCE WITH NRS CHAPTER 278.

---

WILLIAM H. WHITNEY, DIRECTOR,  
PLANNING AND DEVELOPMENT DIVISION

- h. Prior to acceptance of public improvements and release of any financial assurances, the developer shall furnish to the Engineering and Capital Projects Division a complete set of reproducible as-built construction drawings prepared by a civil engineer registered in the State of Nevada.
- i. The developer shall be required to participate in any applicable General Improvement District or Special Assessment District formed by Washoe County.
- j. A note shall be placed on all grading plans and construction drawings stating:

NOTE

Should any prehistoric or historic remains/artifacts be discovered during site development, work shall temporarily be halted at the specific site and the State Historic Preservation Office of the Department of Museums, Library and Arts shall be notified to record and photograph the site. The period of temporary delay shall be limited to a maximum of two (2) working days from the date of notification.

- k. The final map shall designate faults that have been active during the Holocene epoch of geological time, and the final map shall contain the following note:

NOTE

No habitable structures shall be located on a fault that has been active during the Holocene epoch of geological time.

- l. The developer shall provide written approval from the U.S. Postal Service concerning the installation and type of mail delivery facilities. The system, other than individual mailboxes, must be shown on the project construction plans and installed as part of the on-site improvements.
- m. The developer and all successors shall direct any potential purchaser of the site to meet with the Planning and Development Division to review conditions of approval prior to the final sale of the site. Any subsequent purchasers of the site shall notify the Planning and Development Division of the name, address, telephone number and contact person of the new purchaser within thirty (30) days of the final sale.
- n. Failure to comply with the conditions of approval shall render this approval null and void.
- o. Conditions, covenants, and restrictions (CC&Rs), including any supplemental CC&Rs, shall be submitted to the Planning and Development staff for review and subsequent forwarding to the District Attorney for review and approval. The final CC&Rs shall be signed and notarized by the owner(s) and submitted to the Planning and Development Division with the recordation fee prior to the recordation of the final map. The CC&Rs shall require all phases and units of the subdivision approved under this tentative map to be subject to the same CC&Rs. Washoe County shall be made a party to the applicable provisions of the CC&Rs to the satisfaction of the District Attorney's Office. Said CC&Rs shall specifically

address the potential for liens against the properties and the individual property owners' responsibilities for the funding of maintenance, replacement, and perpetuation of the following items, at a minimum:

1. Maintenance of public access easements, common areas, and common open spaces. Provisions shall be made to monitor and maintain, for a period of three (3) years regardless of ownership, a maintenance plan for the common open space area. The maintenance plan for the common open space area shall, as a minimum, address the following:
  - a. Vegetation management;
  - b. Watershed management;
  - c. Debris and litter removal;
  - d. Fire access and suppression; and
  - e. Maintenance of public access and/or maintenance of limitations to public access.
2. All drainage facilities and roadways not maintained by Washoe County shall be privately maintained and perpetually funded by the homeowners association.
3. All open space identified as common area on the final map shall be privately maintained and perpetually funded by the homeowners association. The deed to the open space and common area shall reflect perpetual dedication for that purpose. The maintenance of the common areas and related improvements shall be addressed in the CC&Rs to the satisfaction of the District Attorney's Office.
4. The project adjacent to undeveloped land shall maintain a fire fuel break of a minimum 30 feet in width until such time as the adjacent land is developed.
5. Locating habitable structures on potentially active (Holocene) fault lines, whether noted on the recorded map or disclosed during site preparation, is prohibited.
6. All outdoor lighting on buildings and streets within the subdivision shall be down-shielded.
7. No motorized vehicles shall be allowed on the platted common area.
8. Washoe County will not assume responsibility for maintenance of the private street system of the development nor will Washoe County accept the streets for dedication to Washoe County unless the streets meet those Washoe County standards in effect at the time of offer for dedication.

9. Mandatory solid waste collection.
  10. Fence material (if any), height, and location limitations, and re-fencing standards. Replacement fence must be compatible in materials, finish and location of existing fence.
  11. Slopes shall be three (3) horizontal to one (1) vertical (3:1) or flatter.
  12. Washoe County will not assume responsibility for maintenance of the private street system of the development nor will Washoe County accept the streets for dedication to Washoe County unless the streets meet those Washoe County standards in effect at the time of offer for dedication.
  13. Development of slopes in excess of thirty (30) percent is prohibited.
- p. The common open space owned by the homeowners association shall be noted on the final map as "common open space" and the related deed of conveyance shall specifically provide for the preservation of the common open space in perpetuity. The deed to the open space and common area shall reflect perpetual dedication for that purpose. The deed shall be presented with the CC&Rs for review by the Planning and Development staff and the District Attorney.
  - q. In coordination with the Washoe County Health Department, the University of Nevada Cooperative Extension, and/or the Washoe-Storey Conservation District, the applicant shall prepare and submit a noxious weeds control plan.
  - r. The final map shall identify all areas of general rural (GR) regulatory zone within all residential lots and a note shall be placed on the map shall state that no structures shall be placed within any area identified as GR.
  - s. The final map shall contain the following note: No structures shall be placed within 10 feet from the edge of the transmission line easement.

**Washoe County Engineering and Capital Projects Division**

2. The following conditions are requirements of the Engineering Division, which shall be responsible for determining compliance with these conditions.

**Contact Name** – Walt West, 775.328.2310

- a. Final maps and final construction drawings shall comply with all applicable statutes, ordinances, rules, regulations, and policies in effect at the time of submittal of the tentative map or, if requested by the developer and approved by the applicable agency, those in effect at the time of approval of the final map.
- b. Prior to acceptance of public improvements and release of any financial assurances, the developer shall furnish to the water and sewer provider(s) and Engineering and Capital Projects Division a complete set of reproducible as-built construction drawings prepared by a civil engineer registered in the State of Nevada.



- c. The developer shall be required to participate in any applicable General Improvement District or Special Assessment District formed by Washoe County. The applicable County Department shall be responsible for determining compliance with this condition.
- d. The developer shall provide written approval from the U.S. Postal Service concerning the installation and type of mail delivery facilities. The system, other than individual mailboxes, must be shown on the project construction plans and installed as part of the onsite improvements. The County Engineer shall determine compliance with this condition.
- e. All open space shall be identified as common area on the final map. A note on the final map shall indicate that all common areas shall be privately maintained and perpetually funded by the Homeowners Association. The County Engineer shall determine compliance with this condition. The maintenance of the common areas shall also be addressed in the CC&Rs to the satisfaction of the District Attorney's Office.
- f. Any existing easements or utilities that conflict with the development shall be relocated, quitclaimed, and/or abandoned, as appropriate. The County Engineer shall determine compliance with this condition.
- g. Any easement documents recorded for the project shall include an exhibit map that shows the location and limits of the easement in relationship to the project. The County Engineer shall determine compliance with this condition.
- h. All existing overhead utility lines shall be placed underground, except electric transmission lines greater than 100 kilovolts, which can remain above ground. The County Engineer shall determine compliance with this condition.
- i. A complete set of construction improvement drawings, including an onsite grading plan, shall be submitted to the County Engineer for approval prior to finalization of any portion of the tentative map. Grading shall comply with best management practices (BMP's) and shall include detailed plans for grading and drainage for project roadways, erosion control (including BMP locations and installation details), slope stabilization and mosquito abatement. A conceptual grading and drainage scheme shall be indicated for each lot on the grading plan. If drainage from one lot to another is proposed, then appropriate drainage easements shall be provided. Disposal of any excavated material onsite shall be indicated on the grading plans. The County Engineer shall determine compliance with this condition.
- j. Any roadway crossings of overhead power facilities shall be designed in accordance with Sierra Pacific Power Company (SPPCo) standards. Prior the recordation of any affected map, a letter from SPPCo shall be provided to the County Engineer approving the design and location of roadways with respect the overhead utility lines. The County Engineer shall determine compliance with this condition.
- k. Existing overhead power lines, such as those that traverse lots 8 through 11 and lot 53 shall be relocated underground and easements abandoned with the

recordation of the final map. The County Engineer shall determine compliance with this condition.

***Drainage***

- l. The conditional approval of this tentative map shall not be construed as final approval of the drainage facilities shown on the tentative map. Final approval of the drainage facilities will occur during the final map review and will be based upon the final hydrology report.
- m. Prior to finalization of the first final map, a master hydrology/hydraulic report and a master storm drainage plan shall be submitted to the County Engineer for approval.
- n. Prior to finalization of any portion of the tentative map, a final, detailed hydrology/hydraulic report for that unit shall be submitted to the County Engineer. All storm drainage improvements necessary to serve the project shall be designed and constructed to County standards and specifications and/or financial assurances in an appropriate form and amount shall be provided. The County Engineer shall determine compliance with this condition.
- o. Standard reinforced concrete headwalls or other approved alternatives shall be placed on the inlet and outlet of all drainage structures, and grouted rock riprap shall be used to prevent erosion at the inlets and outlets of all culverts to the satisfaction of the Engineering and Capital Projects Division.
- p. The developer shall provide pretreatment for petrochemicals and silt for all storm drainage leaving the site to the satisfaction of the Engineering Division.
- q. Prior to approval of any final map, building permit, or grading permit, the developer will furnish to the Engineering and Capital Projects Division and Planning and Development staff, written confirmation from the Truckee Meadows Water Authority and the Steamboat Ditch Company, that they have reviewed and approved any ditch crossings, protective fencing or stormwater discharge facilities that may impact the irrigation or water supply ditches, if any.
- r. The Truckee Meadows Regional Stormwater Quality Management Program Construction Permit Submittal Checklist and Inspection Fee shall be submitted with each final map. The County Engineer shall determine compliance with this condition.
- s. Drainage swales that drain more than two lots are not allowed to flow over the curb into the street; these flows shall be intercepted by an acceptable storm drain inlet and routed into the storm drain system. The County Engineer shall determine compliance with this condition.
- t. A note on the final map shall indicate that all drainage facilities not maintained by Washoe County shall be privately maintained and perpetually funded by a homeowners association. As an alternative to a homeowners association, the developer may request the establishment of a County Utility Service Area under which fees would be paid for maintenance of the proposed storm drainage detention facility. The fee amount will be based on the additional service above

that normally provided by the County to maintain new stormwater facilities dedicated by the developer (i.e., curb and gutter, drop inlets and piping). The County Engineer shall determine compliance with this condition. The maintenance and funding of these drainage facilities shall also be addressed in the CC&Rs to the satisfaction of the District Attorney's Office.

- u. The maximum permissible flow velocity (that which does not cause scour) shall be determined for all proposed channels and open ditches. The determination shall be based on a geotechnical analysis of the channel soil, proposed channel lining and channel cross section, and it shall be in accordance with acceptable engineering publications/calculations. Appropriate linings shall be provided for all proposed channels and open ditches such that the 100-year flows do not exceed the maximum permissible flow velocity. The County Engineer shall determine compliance with this condition.
- v. A note on all affected final maps shall state that the owner, buyers, assigns or interest holders of any lots hereon, hereby agree that all existing irrigation flows crossing these parcels shall be perpetuated. Any legal rights to water from the ditches crossing this property shall be honored and the right of access for maintenance and operation will not be denied to valid holders of those rights. The County Engineer shall determine compliance with this condition.
- w. Maintenance access and drainage easements shall be provided for all existing and proposed drainage facilities. The County Engineer shall determine compliance with this condition.
- x. Drainage easements shall be provided across individual lots on the official map for all storm runoff that crosses more than one lot. The County Engineer shall determine compliance with this condition.
- y. Any increase in stormwater runoff resulting from the development and based on the 5 year and 100 year storm(s) shall be detained onsite. The detention facility shall be owned and maintained by a homeowners association. The County Engineer shall determine compliance with this condition.
- z. Any rights-of-way/easements for irrigation ditches or water supply ditches, associate structures and their maintenance shall be reserved with the finalization of the affected final map or prior to issuance of a grading permit. Any relocation of irrigation or water supply facilities shall maintain the quantity, quality, elevation and point of delivery of the ditch unless an alternate alignment and discharge point is approved by the owners of the irrigation and water supply facilities. The County Engineer shall determine compliance with this condition.
- aa. Common Area or offsite drainage draining onto residential lots shall be perpetuated through or around residential lots and drainage facilities capable of passing a 100-year storm shall be constructed with the subdivision improvements to perpetuate the storm water runoff to improved or natural drainage facilities. The County Engineer shall determine compliance with this condition.

## **Traffic and Roadways**

### Discussion

The application indicates that the project roadways may be public roads. The existing Phase 1 was recorded and improved with private streets having 36' wide easements. Should the applicant want Phase 2 roadways to be offered for dedication to Washoe County and maintained as public roadways, all existing streets within Phase 1 shall meet current Washoe County standards including an offer of dedication of right-of-way, pavement width, repair and sealing of existing pavement as directed by the County Engineer, structural section thickness, construction of structural retaining walls adjacent to right-of-ways, and construction of concrete sidewalks

- bb. All roadway improvements necessary to serve the project shall be designed and constructed to County standards and specifications and/or financial assurances in an appropriate form and amount shall be provided. The County Engineer shall determine compliance with this condition.
- cc. Street names shall be reviewed and approved by the Regional Street Naming Coordinator.
- dd. For any utilities placed in existing County streets, the streets shall be repaired to the satisfaction of the County Engineer. At a minimum, this will require full depth removal and replacement of asphalt for half the street width, or replacement of non-woven pavement reinforcing fabric with a 2" asphalt overlay for half the street width. Type II slurry seal is required for the entire street width with either option. Full width street improvements may be required if the proposed utility location is too close to the centerline of the existing street.
- ee. Streetlights shall be constructed to Washoe County standards at locations to be determined at the final design stage. The County Engineer shall determine compliance with this condition.
- ff. AASHTO clear zones shall be determined for all streets adjacent to retaining walls or slopes steeper than 3:1. If a recoverable or traversable clear zone cannot be provided, an analysis to determine if barriers are warranted shall be submitted for approval. The County Engineer shall determine compliance with this condition.
- gg. All retaining walls that are adjacent to, provide support for or retain soil from the County right-of-way shall be constructed of reinforced masonry block or reinforced concrete and designed by an engineer licensed in the State of Nevada. The County Engineer shall determine compliance with this condition.
- hh. No retaining walls that retain soil from the County right-of-way or private right-of-way shall be located within a plowed snow storage easement. The County Engineer shall determine compliance with this condition.
- ii. The conditions, covenants and restrictions (CC&Rs) shall prominently note to the satisfaction of the District Attorney's Office and the County Engineer that Washoe County will not assume responsibility for maintenance of the development's private street system or accept the streets for dedication to Washoe County

unless the streets meet those Washoe County standards in effect at the time of the offer of dedication.

- jj. Adequate snow storage easements shall be identified on the final plat. The County Engineer shall determine compliance with this condition.
- kk. Proposed landscaping and/or fencing along street rights-of-way and within median islands shall be designed to meet AASHTO sight distances and safety guidelines. A minimum vertical clearance of 13.5 feet shall be maintained over all private streets, and no tree shall overhang the curb of any public street. The County Engineer shall determine compliance with this condition.
- ll. The diameter of the cul-de-sac bulb island and anything located within the island, such as landscaping, parking, etc., shall be designed to provide safe sight distances and an adequate turning radius for garbage trucks, snow plows and moving vans. The County Engineer shall determine compliance with this condition.
- mm. If the Engineering Division does not inspect the subdivision improvements, prior to release of any financial assurances for the private improvements, the development shall provide the Engineering Division with a letter prepared by a civil engineer licensed in the State of Nevada, certifying that the private improvements have been constructed in accordance with the approved plans. The County Engineer shall determine compliance with this condition.
- nn. If the project roadways for this tentative map are to be publically owned and maintained by Washoe County, all existing roadways within The Ridges at Hunter Creek Phase 1 development shall meet Washoe County Standards including but not limited to the following:
  - i) Existing roadway right-of-ways shall be offered for dedication to Washoe County being a minimum of 42 feet in width.
  - ii) All streets shall meet standard width requirements with Type 1 curb and gutter and sidewalk in accordance with Washoe County Code requirements.
  - iii) Any roadway improvements comprised of concrete block pavers shall be removed and replaced with standard asphaltic or concrete paving. Alternatively, in lieu of concrete paver removal and roadway reconstruction, the County may allow for maintenance of pavers by a Home Owners Association.
  - iv) All existing roadway islands shall be located in right-of-way granted to Washoe County and a revocable encroachment permit shall be obtained from Washoe County.
  - v) All existing rockery walls that are adjacent to, provide support for or retain soil from the County right-of-way shall are not allowed and shall be re-constructed of reinforced masonry block or reinforced concrete and designed by an engineer licensed in the State of Nevada.

### **Washoe County Utilities**

3. The following conditions are requirements of Washoe County Utilities, which shall be responsible for determining compliance with these conditions.

**Contact Name** – Tim Simpson, 775.954.4648

- a. All fees shall be paid in accordance with Washoe County Ordinance prior to the approval of each final map.
- b. Applicant shall conform to all conditions imposed by intergovernmental agreements required to provide sewer service to the subject project, and, if required, be a party to any such agreements.
- c. Improvement plans shall be submitted and approved by CSD prior to approval of the final map. They shall be in compliance with Washoe County Design Standards and be designed by a Professional Engineer licensed to practice in the State of Nevada.
- d. The Applicant shall submit an electronic copy of the street and lot layout for each final map at initial submittal time. The files must be in a format acceptable to Washoe County.
- e. Approved improvement plans shall be used for the construction of on-site and off-site sanitary sewer collection systems. The CSD will be responsible to inspect the construction of the sanitary sewer collection systems.
- f. Any on-site or off-site previously constructed sanitary sewer collection system not previously accepted by Washoe County shall be adequately flushed, vacuum tested, and video inspected to the satisfaction of the CSD.
- g. The sanitary sewer collection systems must be offered for dedication to Washoe County along with the recordation of each final map.
- h. Easements and real property for all sanitary sewer collection systems and appurtenances shall be offered for dedication to Washoe County along with the recordation of each final map.
- i. A master sanitary sewer report for the entire tentative map shall be prepared and submitted by the applicant's engineer at the time of the initial submittal for the first final map which addresses:
  - i. the estimated sewage flows generated by this project,
  - ii. projected sewage flows from potential or existing development within tributary areas,
  - iii. the impact on capacity of existing infrastructure,
  - iv. slope of pipe, invert elevation and rim elevation for all manholes proposed collection line sizes, on-site and off-site alignment, and half-full velocities.
- j. No Certificate of Occupancy will be issued until all the potable water and sewer collection facilities necessary to serve each final map have been completed and accepted.

- k. No permanent structures (including rockery or retaining walls, building's, etc.) shall be allowed within or upon any County maintained utility easement.
- l. A minimum 30-foot sanitary sewer and access easement shall be dedicated to Washoe County over any facilities not located in a dedicated right of way.
- m. A minimum 12-foot wide all weather sanitary sewer access road shall be constructed to facilitate access to off-site sanitary sewer manholes

**Washoe County Health District**

- 4. The following conditions are requirements of the Health District, which shall be responsible for determining compliance with these conditions. The District Board of Health has jurisdiction over all public health matters in the Health District. Any conditions set by the Health District must be appealed to the District Board of Health.

**Contact Name** – James English and J.L. Shaffer, 775.328.2434

- a. A Water Project per NAC 445A.66695 must be submitted and approved by this Division. Prior to any water system construction, a complete water system plan and Water Project submittal for the referenced proposal must be submitted to this Division. The plan must show that the water system will conform to the State of Nevada Public Water Supply Regulations, NAC Chapter NAC 445A.65505 to 445A.6731, inclusive.
  - i. The application for a Water Project shall conform to the requirements of NAC 445A.66695.
  - ii. Two copies of complete construction plans are required for review. All plans must include an overall site plan, additional phases that will eventually be built to indicate that the water system will be looped, all proposed final grading, utilities, and improvements for the proposed application.
- b. Mass grading may proceed after approval of a favorable review by this Division of a separate mass grading permit application. The application shall include a Truckee Meadows Water Authority annexation and onsite water discovery if applicable.
- c. Prior to approval of any building or site permit for this project, any septic systems on the subject properties shall be abandoned in compliance with the Washoe County Health District Regulations Governing Sewage, Wastewater and Sanitation.
- d. If private streets are proposed for this subdivision the private catch basins will require a water quality insert placed within all basins to improve water quality downstream and prevent mosquitoes from colonizing this infrastructure (Health Regulations Governing the Prevention of Vector-Borne Diseases 040.013).
- e. With rockery walls proposed, the voids in the rockery wall shall be filled by placing smaller rock within the face of the wall for the entire height of the wall (Health Regulations Governing the Prevention of Vector-Borne Diseases 040.081).

- f. If roadside ditches are proposed for the project, the flow line of this infrastructure shall be lined with 4-6 inch rock (Health Regulations Governing the Prevention of Vector-Borne Diseases 040.021).
- g. Prior to the sign off of the building plans the above detail designs are required on the plans and a scheduled compliance inspection with the Vector-Borne Diseases Program is required for the above condition(s).

**Truckee Meadows Fire Protection District (TMFPD)**

- 5. The following conditions are requirements of the Truckee Meadows Fire Protection District, which shall be responsible for determining compliance with these conditions.

**Contact Name** – Amy Ray, 775.326.6000

- a. Any developments on the property shall meet the requirements of WCC 60.
- b. Plans shall be submitted for review and approval to TMFPD.
- c. A Vegetation Management Plan is required for the project in accordance with the requirements of the *International Wildland Urban Interface Code, 2012 Ed.* shall be submitted for approval by TMFPD.
- d. HOA and CC& R requirements and conditions shall be submitted for review, comment and approval by TMFPD prior to recording, adoption and use.
- e. Open spaces and drainages shall be maintained in accordance with WC Code 60, the Vegetation Management Plan and conditions placed in the HOA and CC&R documents, ensuring vegetation management and maintenance in those areas.

**Washoe County Parks and Open Space**

- 6. The following conditions are requirements of the Washoe County Parks and Open Space, which shall be responsible for determining compliance with these conditions.

**Contact Name** – Dennis Troy, 775.328.2059

- a. Washoe County Parks has been working closely with the United States Forest Service (USFS) to improve the trail crossing at Hunter Creek. The existing USFS fire access road is not conducive to trail users and is inaccessible during periods of high flows (Spring runoff, storm periods, etc.). The County would like to expand the existing easement boundaries (Easement Document #3592575) to include an area for a future alignment of a non-motorized pedestrian bridge over Hunter Creek. Please see attachment “A” for this proposed alignment. The County has committed staff resources to prepare these legal descriptions.
- b. It is the County’s desire that the applicant provide a relocatable trail easement to Washoe County such that a future trail alignment can correspond with the USFS trails plan. Preliminary discussions with the USFS have identified a trail alignment on the adjacent property to the south of APN 041-650-02. The trail would ultimately tie into the Hunter Creek trail system and need to cross a portion of APN 041-650-02.



**Washoe County School District**

7. The following condition(s) are requirements of the Washoe County School District, which shall be responsible for determining compliance with these conditions.

**Contact Name** – Mike Boster, 775.789.3810

- a. A disclosure shall be made by the developer to each homebuyer on their closing documents that K-12 students in this subdivision may be assigned to the nearest WCSD school(s) with available capacity in the event that the zoned schools cannot accommodate additional students.

\*\*\* End of Conditions \*\*\*



# West Truckee Meadows Citizen Advisory Board MEMORANDUM

To: Trevor Lloyd, Staff Representative  
From: Misty Moga, Administrative Recorder  
Re: The Ridges at Hunter Creek (Tentative Map Case Number TM16-005)  
Date: June 14, 2016

The following is a portion of the draft minutes of the West Truckee Meadow Citizen Advisory Board held on June 13, 2016.

7. DEVELOPMENT PROJECTS – The project description is provided below with links to the application or you may visit the Planning and Development Division website and select the Application Submittals page:  
[www.washoecounty.us/comdev/da/da\\_index.htm](http://www.washoecounty.us/comdev/da/da_index.htm).

A. The Ridges at Hunter Creek (Tentative Map Case Number TM16-005) – Request for community feedback, discussion and possible approval of a tentative map for 53 lot common open space subdivision. The project is located on 4 parcels which total 155.01 acres. A related master plan amendment and regulatory zone amendment (MPA 15-005 and RZA 15-008) was previously heard by the West Truckee Meadows CAB on November 9, 2015.

- Applicant/Property Owner: Ridges at Hunter Creek LLC and Ridges Development
- Location: South of Woodchuck Circle and Hunters Peak Road and West of Hawken Drive
- APN: 041-671-01, 041-650-02, 041-662-12 and 41-650-03
- Staff: Trevor Lloyd, Senior Planner Washoe County Community Services Department, 775-328-3620 or [tlloyd@washoecounty.us](mailto:tlloyd@washoecounty.us)
- Reviewing Body: This item is tentatively scheduled for review by the Washoe County Planning Commission on July 5, 2016

Trevor Lloyd said this project came to this board last fall. The applicants are asking subdivision of 53 lots, an extension of previous tentative map. He said this project will be heard by the Planning Commission on July 5.

Melissa Lindell, Planner with Wood Rogers, presented the project:

- She said they hosted a neighborhood meeting
- The project is on 155 acres site with common open space
- Phase two of the project had expired.
- TMWA Discovery process stated 50 lots are within service area.
- Preliminary report.
- She said they will pay for water for 53 lots. There is more than enough water.
- People are concerned with capacity at local schools when new development happens, but that isn't a problem in this area. They can handle the development.
- There is a lot of public land surrounding it with a trail head in the north off of Huntercreek.
- Linda Heist asked about the density. Melissa said 53 lots approved under zoning. She said they can make the lots any size. Melissa said its threshold is 80 daily trips to conduct a traffic study. There was existing density. It's under capacity as far as traffic and schools.
- Melissa said they had a meeting at the Dixon Realty. The neighbors within 750 feet of this project were notified.
- Zelalem Bogale asked about public land. He asked if there is a potential to build out later, a possible phase three. Melissa showed a slope map of the area. The red indicates land with slope more than 30%. They can do 1 per 4 acre if they want to develop. It's very steep. There is a little access easement. Trevor said the other land is out of TMWA services area, especially where it's steep.
- Sean McCoy said he can understand why the units are clustered based on the slope map. Melissa said it was always planned to be clustered. Melissa said when they received the approval; they found additional land that TMWA can serve. If those additional lots don't work, they may end up with 52 or 51 lots instead of 53.
- Trevor Lloyd said there won't be mass grading. Most of the grading has taken place. These will be custom home with natural terrain. Not a lot of grading.
- George asked about private or public roads. Melissa said they are studying the options. It will likely be sold to a developer who will decide if they want public or private roads. It was planned as gated community, but has the option

**WMPA23-0008 AND  
WRZA23-0009  
EXHIBIT F**

to have a public neighborhood. Washoe County will require road standards. It would be costly for the developers to upgrade the roads.

- Secondary access will be on Caughlin Ranch. It's graded out from the cul-de-sac. It is an established emergency access with turnouts required. Part of the map was approved before it was expired. That's why the utilities are stubbed, roads and access.
- Zelalem Bogale asked about the timeline for when the homes will be built. Trevor said the subdivision and recording has a timeline, but there is no limit on the time they need to build. Custom lot development; people buy lots but don't necessarily start building. Trevor said all necessary infrastructures are in place.
- George asked about the phases. Melissa said there will be phases with attention to utilities and access. It's possible to come in with phases. Roads would have to be paved and utilities installed before lots sold.
- The client has no plan to sell any of the lots yet; they are just getting organized and sorted. No plan to sell lots in the next years.
- The first 16 lots have their utilities in and they are ready to go.
- The applicant said they are just trying to get the package complete. It will be determined by the whole package.
- One developer will put in the infrastructure. It's a small, custom development.
- The cost; these lots will be very expensive. CCRs have been recorded.
- This development is very similar to the Eagle's Nest development in Caughlin Ranch. There will be restrictions per lot.
- The CCRs have been approved on the first 16 lots; the same CCRs will be applied to the remaining 53 lots, for a total of 69 lots. Sean McCoy said that will be the ceiling; but once it's all finish up and hand it off to the development, they can determine it will only be 20 houses, but 53 is the max. The lots can be merged.
- Historical data and recent sales – rough estimate of each lot will be between \$300-\$800K.
- George asked the removal of trees south of Hunter Falls Circle. Melissa clarified it was for the road.

Motion: Linda recommends approval with concerns regarding the Plateau and Juniper Ridge traffic. Zelalem Bogale moved to approve with comments regarding traffic. Charles Guffey seconded the motion. Motion carried unanimously.

cc: George Georgeson, Chair  
Marsha Berkbigler, Commissioner  
Al Rogers, Constituent Services  
Sarah Tone, Constituent Services



Date: June 8, 2016

To: Trevor Lloyd, Senior Planner

From: Walter H. West, P.E., Licensed Engineer

Re: ***THE RIDGES AT HUNTER CREEK-PHASE II, TM16-005*** (53 Lots)

### **GENERAL PROJECT DISCUSSION**

The proposed project consists of 53 residential lots generally south of the existing Ridges at Hunter Creek Phase I development. The primary access for the project is from Woodchuck Circle with existing emergency access roadways. The Engineering and Capital Projects Division offers the following comments and recommendations, which supplement applicable County Code and are based upon our review of the site and the tentative map application prepared by Wood Rodgers.

#### Recommended Conditions of Approval

The following conditions of approval should be applied to this proposed project. Conditions in *italics* are standard Engineering Conditions.

### **GENERAL CONDITIONS**

- 1. Final maps and final construction drawings shall comply with all applicable statutes, ordinances, rules, regulations, and policies in effect at the time of submittal of the tentative map or, if requested by the developer and approved by the applicable agency, those in effect at the time of approval of the final map.*
- 2. Prior to acceptance of public improvements and release of any financial assurances, the developer shall furnish to the water and sewer provider(s) and Engineering and Capital Projects Division a complete set of reproducible as-built construction drawings prepared by a civil engineer registered in the State of Nevada.*
- 3. The developer shall be required to participate in any applicable General Improvement District or Special Assessment District formed by Washoe County. The applicable County Department shall be responsible for determining compliance with this condition.*
- 4. The developer shall provide written approval from the U.S. Postal Service concerning the installation and type of mail delivery facilities. The system, other than individual mailboxes, must be shown on the project construction plans and installed as part of the onsite improvements. The County Engineer shall determine compliance with this condition.*
- 5. All open space shall be identified as common area on the final map. A note on the final map shall indicate that all common areas shall be privately maintained and perpetually funded by the Homeowners Association. The County Engineer shall determine compliance with this condition.*

*The maintenance of the common areas shall also be addressed in the CC&Rs to the satisfaction of the District Attorney's Office.*

6. *Any existing easements or utilities that conflict with the development shall be relocated, quitclaimed, and/or abandoned, as appropriate. The County Engineer shall determine compliance with this condition.*
7. *Any easement documents recorded for the project shall include an exhibit map that shows the location and limits of the easement in relationship to the project. The County Engineer shall determine compliance with this condition.*
8. *All existing overhead utility lines shall be placed underground, except electric transmission lines greater than 100 kilovolts, which can remain above ground. The County Engineer shall determine compliance with this condition.*
9. *A complete set of construction improvement drawings, including an onsite grading plan, shall be submitted to the County Engineer for approval prior to finalization of any portion of the tentative map. Grading shall comply with best management practices (BMP's) and shall include detailed plans for grading and drainage for project roadways, erosion control (including BMP locations and installation details), slope stabilization and mosquito abatement. A conceptual grading and drainage scheme shall be indicated for each lot on the grading plan. If drainage from one lot to another is proposed, then appropriate drainage easements shall be provided. Disposal of any excavated material onsite shall be indicated on the grading plans. The County Engineer shall determine compliance with this condition.*
10. *Any roadway crossings of overhead power facilities shall be designed in accordance with Sierra Pacific Power Company (SPPCo) standards. Prior the recordation of any affected map, a letter from SPPCo shall be provided to the County Engineer approving the design and location of roadways with respect the overhead utility lines. The County Engineer shall determine compliance with this condition.*
11. *Existing overhead power lines, such as those that traverse lots 8 through 11 and lot 53 shall be relocated underground and easements abandoned with the recordation of the final map. The County Engineer shall determine compliance with this condition.*

#### **DRAINAGE (COUNTY CODE 110.420)**

1. *The conditional approval of this tentative map shall not be construed as final approval of the drainage facilities shown on the tentative map. Final approval of the drainage facilities will occur during the final map review and will be based upon the final hydrology report.*
2. *Prior to finalization of the first final map, a master hydrology/hydraulic report and a master storm drainage plan shall be submitted to the County Engineer for approval.*
3. *Prior to finalization of any portion of the tentative map, a final, detailed hydrology/hydraulic report for that unit shall be submitted to the County Engineer. All storm drainage improvements necessary to serve the project shall be designed and constructed to County standards and specifications and/or financial assurances in an appropriate form and amount shall be provided. The County Engineer shall determine compliance with this condition.*
4. *Standard reinforced concrete headwalls or other approved alternatives shall be placed on the inlet and outlet of all drainage structures, and grouted rock riprap shall be used to prevent*

*erosion at the inlets and outlets of all culverts to the satisfaction of the Engineering and Capital Projects Division.*

- 5. The developer shall provide pretreatment for petrochemicals and silt for all storm drainage leaving the site to the satisfaction of the Engineering Division.*
- 6. Prior to approval of any final map, building permit, or grading permit, the developer will furnish to the Engineering and Capital Projects Division and Planning and Development staff, written confirmation from the Truckee Meadows Water Authority and the Steamboat Ditch Company, that they have reviewed and approved any ditch crossings, protective fencing or stormwater discharge facilities that may impact the irrigation or water supply ditches, if any.*
- 7. The Truckee Meadows Regional Stormwater Quality Management Program Construction Permit Submittal Checklist and Inspection Fee shall be submitted with each final map. The County Engineer shall determine compliance with this condition.*
- 8. Drainage swales that drain more than two lots are not allowed to flow over the curb into the street; these flows shall be intercepted by an acceptable storm drain inlet and routed into the storm drain system. The County Engineer shall determine compliance with this condition.*
- 9. A note on the final map shall indicate that all drainage facilities not maintained by Washoe County shall be privately maintained and perpetually funded by a homeowners association. As an alternative to a homeowners association, the developer may request the establishment of a County Utility Service Area under which fees would be paid for maintenance of the proposed storm drainage detention facility. The fee amount will be based on the additional service above that normally provided by the County to maintain new stormwater facilities dedicated by the developer (i.e., curb and gutter, drop inlets and piping). The County Engineer shall determine compliance with this condition. The maintenance and funding of these drainage facilities shall also be addressed in the CC&Rs to the satisfaction of the District Attorney's Office.*
- 10. The maximum permissible flow velocity (that which does not cause scour) shall be determined for all proposed channels and open ditches. The determination shall be based on a geotechnical analysis of the channel soil, proposed channel lining and channel cross section, and it shall be in accordance with acceptable engineering publications/calculations. Appropriate linings shall be provided for all proposed channels and open ditches such that the 100-year flows do not exceed the maximum permissible flow velocity. The County Engineer shall determine compliance with this condition.*
- 11. A note on all affected final maps shall state that the owner, buyers, assigns or interest holders of any lots hereon, hereby agree that all existing irrigation flows crossing these parcels shall be perpetuated. Any legal rights to water from the ditches crossing this property shall be honored and the right of access for maintenance and operation will not be denied to valid holders of those rights. The County Engineer shall determine compliance with this condition.*
- 12. Maintenance access and drainage easements shall be provided for all existing and proposed drainage facilities. The County Engineer shall determine compliance with this condition.*
- 13. Drainage easements shall be provided across individual lots on the official map for all storm runoff that crosses more than one lot. The County Engineer shall determine compliance with this condition.*
- 14. Any increase in stormwater runoff resulting from the development and based on the 5 year and 100 year storm(s) shall be detained onsite. The detention facility shall be owned and maintained*

by a homeowners association. The County Engineer shall determine compliance with this condition.

15. Any rights-of-way/easements for irrigation ditches or water supply ditches, associate structures and their maintenance shall be reserved with the finalization of the affected final map or prior to issuance of a grading permit. Any relocation of irrigation or water supply facilities shall maintain the quantity, quality, elevation and point of delivery of the ditch unless an alternate alignment and discharge point is approved by the owners of the irrigation and water supply facilities. The County Engineer shall determine compliance with this condition.
16. Common Area or offsite drainage draining onto residential lots shall be perpetuated through or around residential lots and drainage facilities capable of passing a 100-year storm shall be constructed with the subdivision improvements to perpetuate the storm water runoff to improved or natural drainage facilities. The County Engineer shall determine compliance with this condition.

## **TRAFFIC AND ROADWAY (COUNTY CODE 110.436)**

### Discussion

The application indicates that the project roadways may be public roads. The existing Phase 1 was recorded and improved with private streets having 36' wide easements. Should the applicant want Phase 2 roadways to be offered for dedication to Washoe County and maintained as public roadways, all existing streets within Phase 1 shall meet current Washoe County standards including an offer of dedication of right-of-way, pavement width, repair and sealing of existing pavement as directed by the County Engineer, structural section thickness, construction of structural retaining walls adjacent to right-of-ways, and construction of concrete sidewalks.

1. *All roadway improvements necessary to serve the project shall be designed and constructed to County standards and specifications and/or financial assurances in an appropriate form and amount shall be provided. The County Engineer shall determine compliance with this condition.*
2. *Street names shall be reviewed and approved by the Regional Street Naming Coordinator.*
3. *For any utilities placed in existing County streets, the streets shall be repaired to the satisfaction of the County Engineer. At a minimum, this will require full depth removal and replacement of asphalt for half the street width, or replacement of non-woven pavement reinforcing fabric with a 2" asphalt overlay for half the street width. Type II slurry seal is required for the entire street width with either option. Full width street improvements may be required if the proposed utility location is too close to the centerline of the existing street.*
4. *Streetlights shall be constructed to Washoe County standards at locations to be determined at the final design stage. The County Engineer shall determine compliance with this condition.*
5. *AASHTO clear zones shall be determined for all streets adjacent to retaining walls or slopes steeper than 3:1. If a recoverable or traversable clear zone cannot be provided, an analysis to determine if barriers are warranted shall be submitted for approval. The County Engineer shall determine compliance with this condition.*
6. *All retaining walls that are adjacent to, provide support for or retain soil from the County right-of-way shall be constructed of reinforced masonry block or reinforced concrete and designed by an*

*engineer licensed in the State of Nevada. The County Engineer shall determine compliance with this condition.*

7. *No retaining walls that retain soil from the County right-of-way or private right-of-way shall be located within a plowed snow storage easement. The County Engineer shall determine compliance with this condition.*
8. *The conditions, covenants and restrictions (CC&Rs) shall prominently note to the satisfaction of the District Attorney's Office and the County Engineer that Washoe County will not assume responsibility for maintenance of the development's private street system or accept the streets for dedication to Washoe County unless the streets meet those Washoe County standards in effect at the time of the offer of dedication.*
9. *Adequate snow storage easements shall be identified on the final plat. The County Engineer shall determine compliance with this condition.*
10. *Proposed landscaping and/or fencing along street rights-of-way and within median islands shall be designed to meet AASHTO sight distances and safety guidelines. A minimum vertical clearance of 13.5 feet shall be maintained over all private streets, and no tree shall overhang the curb of any public street. The County Engineer shall determine compliance with this condition.*
11. *The diameter of the cul-de-sac bulb island and anything located within the island, such as landscaping, parking, etc., shall be designed to provide safe sight distances and an adequate turning radius for garbage trucks, snow plows and moving vans. The County Engineer shall determine compliance with this condition.*
12. *If the Engineering Division does not inspect the subdivision improvements, prior to release of any financial assurances for the private improvements, the development shall provide the Engineering Division with a letter prepared by a civil engineer licensed in the State of Nevada, certifying that the private improvements have been constructed in accordance with the approved plans. The County Engineer shall determine compliance with this condition.*
13. *If the project roadways for this tentative map are to be publically owned and maintained by Washoe County, all existing roadways within The Ridges at Hunter Creek Phase 1 development shall meet Washoe County Standards including but not limited to the following:*
  - a) *Existing roadway right-of-ways shall be offered for dedication to Washoe County being a minimum of 42 feet in width.*
  - b) *all streets shall meet standard width requirements with Type 1 curb and gutter and sidewalk in accordance with Washoe County Code requirements.*
  - c) *Any roadway improvements comprised of concrete block pavers shall be removed and replaced with standard asphaltic or concrete paving. Alternatively, in lieu of concrete paver removal and roadway reconstruction, the County may allow for maintenance of pavers by a Home Owners Association*
  - d) *all existing roadway islands shall be located in right-of-way granted to Washoe County and a revocable encroachment permit shall be obtained from Washoe County.*
  - e) *All existing rockery walls that are adjacent to, provide support for or retain soil from the County right-of-way shall are not allowed and shall be re-constructed of reinforced masonry block or reinforced concrete and designed by an engineer licensed in the State of Nevada.*

*The County Engineer shall determine compliance with this condition.*



# WASHOE COUNTY HEALTH DISTRICT

ENHANCING QUALITY OF LIFE

June 28, 2016

Trevor Lloyd, Senior Planner  
Washoe County Community Services  
Planning and Development Division  
PO Box 11130  
Reno, NV 89520-0027

RE: The Ridges at Hunter Creek; APN: 041-671-01,041-650-02, 041-662-12, 41-650-03  
Tentative Map; TM16-005

Dear Mr. Lloyd:

The Washoe County Health District, Environmental Health Services Division (Division) Engineering and Vector borne Diseases Program have reviewed the above referenced project. Approval by this Division is subject to the following conditions:

1. A Water Project per NAC 445A.66695 must be submitted and approved by this Division. Prior to any water system construction, a complete water system plan and Water Project submittal for the referenced proposal must be submitted to this Division. The plan must show that the water system will conform to the State of Nevada Public Water Supply Regulations, NAC Chapter NAC 445A.65505 to 445A.6731, inclusive.
  - a. The application for a Water Project shall conform to the requirements of NAC 445A.66695.
  - b. Two copies of complete construction plans are required for review. All plans must include an overall site plan, additional phases that will eventually be built to indicate that the water system will be looped, all proposed final grading, utilities, and improvements for the proposed application.
2. Mass grading may proceed after approval of a favorable review by this Division of a separate mass grading permit application.
  - a. The application shall include a Truckee Meadows Water Authority annexation and onsite water discovery if applicable.
3. Prior to approval of any building or site permit for this project, any septic systems on the subject properties shall be abandoned in compliance with the Washoe County Health District Regulations Governing Sewage, Wastewater and Sanitation.
4. If private streets are proposed for this subdivision the private catch basins will require a water quality insert placed within all basins to improve water quality downstream and prevent mosquitoes from colonizing this infrastructure (Health Regulations Governing the Prevention of Vector-Borne Diseases 040.013).
5. With rockery walls proposed, the voids in the rockery wall shall be filled by placing smaller rock within the face of the wall for the entire height of the wall (Health Regulations Governing the Prevention of Vector-Borne Diseases 040.081).
6. If roadside ditches are proposed for the project, the flow line of this infrastructure shall be lined with 4-6 inch rock (Health Regulations Governing the Prevention of Vector-Borne Diseases 040.021).

**WMPA23-0008 AND  
WRZA23-0009  
EXHIBIT F**

7. Prior to the sign off of the building plans the above detail designs are required on the plans and a scheduled compliance inspection with the Vector-Borne Diseases Program is required for the above condition(s).

If you have any questions regarding the foregoing, please call Jim English at 328-2610 or Jim Shaffer 785-4599 regarding engineering or vector comments, respectively.

Sincerely,

James English  
Environmental Health Specialists Supervisor  
Environmental Health Services

J.L. Shaffer  
Program Coordinator/Planner  
Vector-Borne Diseases Program  
Environmental Health Services

CA/JS:wr

Cc: File - Washoe County Health District  
Wood Rodgers – sstrickland@woodrogers.com



---

June 10, 2016

To: Trevor Lloyd, Community Development  
From: Timothy Simpson P.E., Environmental Engineer II  
Subject: TM16-005, Ridges at Hunter Creek Phase II (53 lots)

***The Washoe County Community Services Department (CSD) Utility Services Division has reviewed the subject application and has the following comments:***

1. The applicant is proposing to develop four parcels totaling approximately 155 acres in the Southwest Truckee Meadows Planning Area totaling 53 units.
2. Sanitary sewer service will be provided by Washoe County with treatment at the Truckee Meadows Water Reclamation Facility.

***The Washoe County Community Services Department (CSD) Utility Services Division recommends approval provided the following conditions are met:***

1. All fees shall be paid in accordance with Washoe County Ordinance prior to the approval of each final map.
2. Applicant shall conform to all conditions imposed by intergovernmental agreements required to provide sewer service to the subject project, and, if required, be a party to any such agreements.
3. Improvement plans shall be submitted and approved by CSD prior to approval of the final map. They shall be in compliance with Washoe County Design Standards and be designed by a Professional Engineer licensed to practice in the State of Nevada.
4. The Applicant shall submit an electronic copy of the street and lot layout for each final map at initial submittal time. The files must be in a format acceptable to Washoe County.
5. Approved improvement plans shall be used for the construction of on-site and off-site sanitary sewer collection systems. The CSD will be responsible to inspect the construction of the sanitary sewer collection systems.
6. Any on-site or off-site previously constructed sanitary sewer collection system not previously accepted by Washoe County shall be adequately flushed, vacuum tested, and video inspected to the satisfaction of the CSD.
7. The sanitary sewer collection systems must be offered for dedication to Washoe County along with the recordation of each final map.

8. Easements and real property for all sanitary sewer collection systems and appurtenances shall be offered for dedication to Washoe County along with the recordation of each final map.
9. A master sanitary sewer report for the entire tentative map shall be prepared and submitted by the applicant's engineer at the time of the initial submittal for the first final map which addresses:
  - a. the estimated sewage flows generated by this project,
  - b. projected sewage flows from potential or existing development within tributary areas,
  - c. the impact on capacity of existing infrastructure,
  - d. slope of pipe, invert elevation and rim elevation for all manholes
  - e. proposed collection line sizes, on-site and off-site alignment, and half-full velocities
10. No Certificate of Occupancy will be issued until all the potable water and sewer collection facilities necessary to serve each final map have been completed and accepted.
11. No permanent structures (including rockery or retaining walls, building's, etc.) shall be allowed within or upon any County maintained utility easement.
12. A minimum 30-foot sanitary sewer and access easement shall be dedicated to Washoe County over any facilities not located in a dedicated right of way.
13. A minimum 12-foot wide all weather sanitary sewer access road shall be constructed to facilitate access to off-site sanitary sewer manholes.



## MEMORANDUM

DEPARTMENT OF REGIONAL PARKS AND OPEN SPACE

PLANNING DIVISION



---

**TO:** Trevor Lloyd, Senior Planner

**FROM:** Dennis Troy, Park Planner

**DATE:** June 7, 2016

**SUBJECT:** TM16-005 – Tentative Map (The Ridges at Hunter Creek)

---

Tentative Subdivision Case No. TM13-002 – Eagle Canyon Ranch Unit 1

The proposed development lies within Park District 1B and the Michael D. Thompson trail head is located on APN 041-650-02 (per Easement Document #3592575). Washoe County's also owns a 6.5 acre parcel that provides overflow parking and an access road to the trail head.

1. Washoe County Parks has been working closely with the United States Forest Service (USFS) to improve the trail crossing at Hunter Creek. The existing USFS fire access road is not conducive to trail users and is inaccessible during periods of high flows (Spring runoff, storm periods etc.). The County would like to expand the existing easement boundaries (Easement Document #3592575) to include an area for a future alignment of a non-motorized pedestrian bridge over Hunter Creek. Please see attachment "A" for this proposed alignment. The County has committed staff resources to prepare these legal descriptions.
2. It is the County's desire that the applicant provide a relocatable trail easement to Washoe County such that a future trail alignment can correspond with the USFS trails plan. Preliminary discussions with the USFS have identified a trail alignment on the adjacent property to the south of APN 041-650-02. The trail would ultimately tie into the Hunter Creek trail system and need to cross a portion of APN 041-650-02.

# Attachment "A"

Portion of easement #3592575 to be expanded to allow for alignment of bridge crossing Hunter Creek

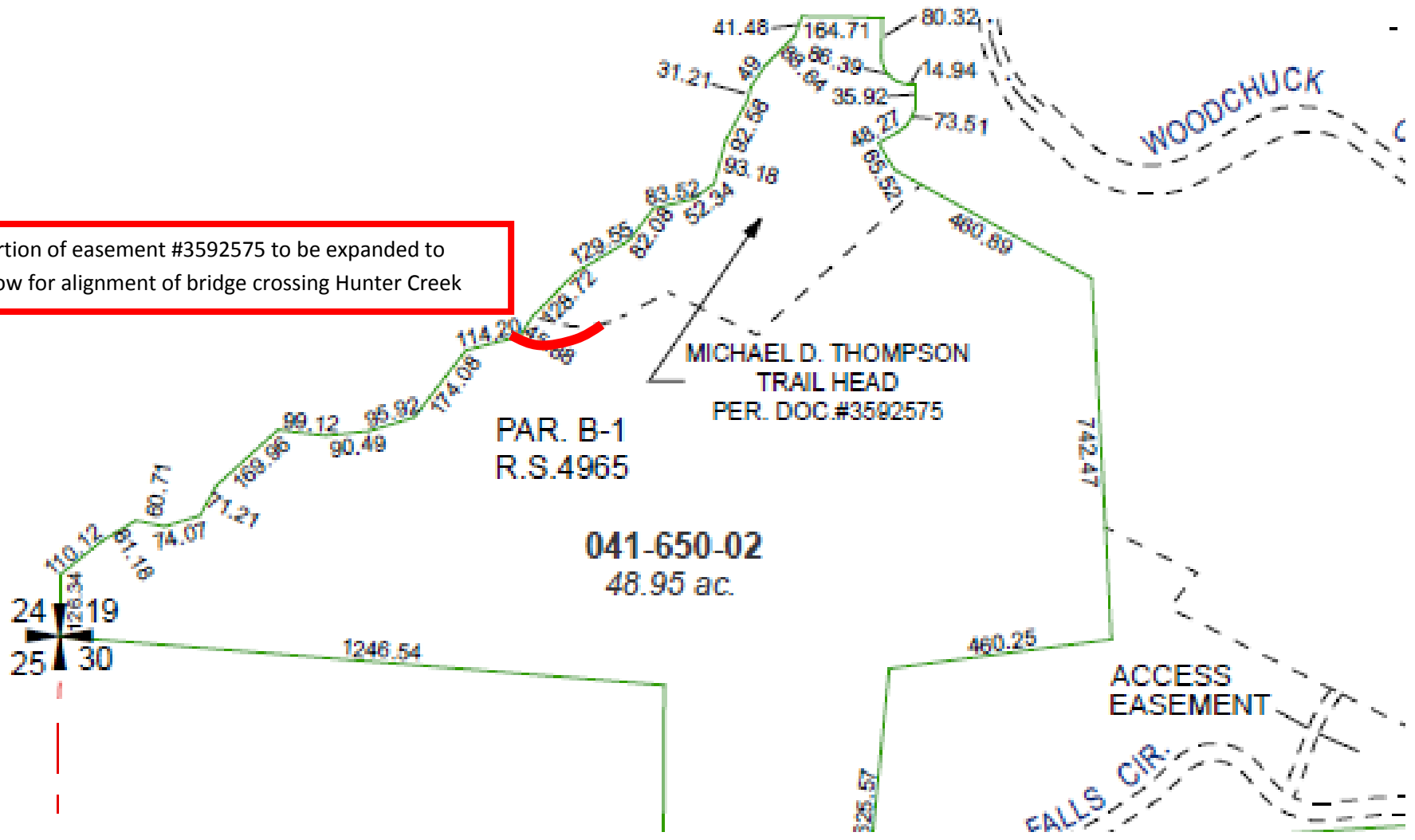



NEVADA DIVISION OF  
**ENVIRONMENTAL  
PROTECTION**

**STATE OF NEVADA**  
Department of Conservation & Natural Resources  
Brian Sandoval, Governor  
Leo M. Drozdoff, P.E., Director  
David Emme, Administrator

**RECEIVED**  
**JUN - 3 2016**  
**WASHOE COUNTY  
COMMUNITY DEVELOPMENT**

June 1, 2016  
BOB SACK  
DISTRICT HEALTH  
P.O. BOX 11130  
RENO, NV 89520

**Re: Tentative Map-The Ridges at Hunter Creek Phase II, APN: 041-650-02, 041-650-03, 041-662-12, 041-671-01; 53 Lots in Washoe County**

Dear Mr. SACK:

The Nevada Division of Environmental Protection has reviewed the above referenced subdivision and recommends approval of said subdivision with respect to water pollution and sewage disposal, provided that the Washoe County commits to provide sewage service to said subdivision.

Please note that if the developer of this subdivision will disturb more than one acre, he/she is required to obtain coverage under NDEP's Construction Stormwater General Permit NVR100000. A Notice of Intent must be filed electronically and submitted with a \$200 fee prior to commencing any earth-disturbing activities at the site. Visit NDEP's Bureau of Water Pollution Control's website at: [http://ndep.nv.gov/bwpc/storm\\_cont03.htm](http://ndep.nv.gov/bwpc/storm_cont03.htm) for more information about this permit.

Sincerely,

Alexis Perkins  
Technical Services Branch  
Bureau of Water Pollution Control

cc:

-- -- Washoe County Department of Water Resources, Utility Division, P.O. 11130 Reno 89520  
-- -- , Comprehensive Planning, P.O. 11130 Reno 89520  
Engineer: WOOD RODGERS 5440 Reno Corporate Dr Reno, NV 89511  
Developer Name: RIDGES AT HUNTER CREEK LLC 4345 Eagle Valley Circle Reno, NV 89519

Control No. 10801

**WMPA23-0008 AND  
WRZA23-0009  
EXHIBIT F**



**DEPARTMENT OF CONSERVATION AND NATURAL RESOURCES  
DIVISION OF WATER RESOURCES**

901 South Stewart Street, Suite 2002  
Carson City, Nevada 89701-5250  
(775) 684-2800 • Fax (775) 684-2811  
(800) 992-0900  
(In Nevada Only)  
[www.water.nv.gov](http://www.water.nv.gov)

May 24, 2016

**RE:** Comments on TM16-005

**To:** Katy Stark  
Washoe County Community Services Department  
1001 East Ninth Street, Building A  
Reno, NV 89512

**Name:** *The Ridges at Hunter Creek Phase II*

**County:** Washoe County – Plateau Road and Hunters Peak Road

**Location:** A portion of Section 30, Township 19 North, Range 19, East, MDB&M.

**Plat:** Tentative: Fifty-three (53) lot totaling approximately 155.01 acres and being Washoe County Assessor's Parcel Numbers 041-671-01, 041-650-02, 041-662-12, and 041-650-13.

**Water Service  
Commitment**

**Allocation:** No water is committed at this time.

**Owner-  
Developer:** Ransom W. Webster  
4345 Eagle Valley Circle  
Reno, NV 89519

**Engineer:** Wood Rodgers, Inc.  
5440 Reno Corporate Drive  
Reno, NV 89511

**Water  
Supply:** Truckee Meadows Water Authority

**WMPA23-0008 AND  
WRZA23-0009  
EXHIBIT F**



**General:** There are no active water rights appurtenant to the described lands in this proposed project. The lands of the proposed project lie within the Truckee Meadows Water Authority service area. Any water used on the described lands should be provided by an established utility or under permit issued by the State Engineer's Office.

All waters of the State belong to the public and may be appropriated for beneficial use pursuant to the provisions of Chapters 533 and 534 of the Nevada Revised Statutes (NRS), and not otherwise.

Any water or monitor wells, or boreholes that may be located on either acquired or transferred lands are the ultimate responsibility of the owner of the property at the time of the transfer and must be plugged and abandoned as required in Chapter 534 of the Nevada Administrative Code. If artesian water is encountered in any well or borehole it shall be controlled as required in NRS § 534.060(3).

Municipal water service is subject to Truckee Meadows Water Authority rules and regulations and approval by the Office of the State Engineer regarding water quantity and availability.

A Will Serve from Truckee Meadows Water Authority and mylar map of the proposed project must be presented to the State Engineer for approval and signed through his office prior to development.

**Action:** Tentative approval of **The Ridges at Hunter Creek Phase II** subdivision based on acceptance of Water Will Serve by Truckee Meadows Water Authority.

Best regards,

Steve Shell  
Water Resource Specialist II

Amy Ray  
*Fire Marshal*



Tim Leighton  
*Division Chief*

Charles A. Moore  
*Fire Chief*

June 9, 2016

Washoe County Community Services Department  
1001 East Ninth Street  
Reno, NV 89512

Re: Master Plan Amendment Case No. TM 16-005 (The Ridges at Hunter Creek Phase II)

The Truckee Meadows Fire Protection District (TMFPD) will approve the above MPA with the following conditions:

- Any developments on the property shall meet the requirements of WCC 60.
- Plans shall be submitted for review and approval to TMFPD.
- A Vegetation Management Plan is required for the project in accordance with the requirements of the *International Wildland Urban Interface Code, 2012 Ed.* shall be submitted for approval by TMFPD.
- HOA and CC& R requirements and conditions shall be submitted for review, comment and approval by TMFPD prior to recording, adoption and use.
- Open spaces and drainages shall be maintained in accordance with WC Code 60, the Vegetation Management Plan and conditions placed in the HOA and CC&R documents, ensuring vegetation management and maintenance in those areas.

Please contact me with any questions at (775) 326-6005.

Thank you,

Amy Ray  
Fire Marshal

**TRUCKEE MEADOWS FIRE PROTECTION DISTRICT**

1001 E. Ninth St. Bldg D 2nd Floor • Reno, Nevada 89512 • PO Box 11130 • Reno, Nevada 89520  
Office 775.326.6000 Fax 775.326.6003



**Washoe County School District**

425 East Ninth Street \* P.O. Box 30425 \* Reno, NV 89520-3425  
Phone (775) 348-0200 \* (775) 348-0304 \* [www.washoeschools.net](http://www.washoeschools.net)

Board of Trustees: Angela Taylor, President \* John Mayer, Vice President \* Veronica Frenkel, Clerk \*  
Barbara McLaury \* Howard Rosenberg \* Lisa Ruggerio \* Traci Davis, Superintendent

24 May 2016

Trevor U. Lloyd, Senior Planner  
Washoe County Community Services Department  
1001 East Ninth Street  
Reno NV USA 89512

RE: **TM16-005 (The Ridges at Hunter Creek)**

Dear Mr Lloyd,

53 new single-family residential units will impact Washoe County School District facilities. This project is currently zoned for the following schools:

**Caughlin Ranch Elementary School**

- **Estimated project impact = 7 new ES students (53 single-family units x 0.137 ES students per unit)**
- **Base Capacity = 606**
- **2015-2016 Enrollment = 560**
- **% of Base Capacity = 92%**
- **Portable units onsite = 0**
- **Overcrowding Strategy** – The Caughlin Ranch ES property may be able to accommodate portable classroom units if necessary. However, portables do not provide additional lunchroom, computer lab or playground/sports field space and are intended to be temporary measures to be used prior to new school construction. WCSD does not currently have a sufficient funding source for new school construction. On September 22, 2015, the WCSD Board of Trustees set 120% of capacity as the conversion threshold for eligible elementary schools to be converted to a multi-track year-round (MTYR) calendar. **Caughlin Ranch is not anticipated to go to the MTYR schedule for the 2016-2017 School Year.**



### Swope Middle School

- **Estimated project impact = 3** new MS students (**53** single-family units x **0.063** MS students per unit)
- **Base Capacity = 853**
- **2015-2016 Enrollment = 733**
- **% of Base Capacity = 86%**
- **Portable units onsite = 0**
- **Overcrowding Strategy** – The **Swope MS** property may be able to accommodate portable classrooms if necessary. However, portables do not provide additional lunchroom, computer lab or playground/sports field space and are intended to be temporary measures to be used prior to new school construction. WCSD does not currently have a sufficient funding source for new school construction. **Assignment to the closest middle school with available capacity may be used for students in this development if Swope MS exceeds capacity prior to buildout.**

### Reno Ranch High School

- **Estimated project impact = 4** new HS students (**53** single-family units x **0.074** HS students per unit)
- **Base Capacity = 1965**
- **2015-2016 Enrollment = 1703**
- **% of Base Capacity = 87%**
- **Portable units onsite = 2**
- **Overcrowding Strategy** – The **Reno** High School property currently has 2 portable buildings (**3** classrooms) in use. Portables do not provide additional lunchroom, computer lab or sports field space and are intended to be temporary measures to be used prior to new school construction. WCSD does not currently have a sufficient funding source for new school construction. **Assignment to the closest high school with available capacity may be used for students in this development if Reno HS exceeds capacity prior to buildout.**

Recommended WCSD Condition for **TM16-005 (The Ridges at Hunter Creek)**:  
*A disclosure shall be made by the developer to each homebuyer on their closing documents that K-12 students in this subdivision may be assigned to the nearest WCSD school(s) with available capacity in the event that the zoned schools cannot accommodate additional students.*

Thank you for the opportunity to comment.



**Mike Boster**  
School Planner  
14101 Old Virginia Road  
Reno NV USA 89521  
Washoe County School District Capital Projects  
775.789.3810  
[mboster@washoeschools.net](mailto:mboster@washoeschools.net)



Washoe-Storey  
Conservation  
District

Natural Resource  
Conservation Service  
1365 Corporate Blvd.  
Reno, NV 89502

Tel: (775) 857-8500  
ext. 131  
Fax: (775) 857-8525

Board of Supervisors:

Bret Tyler  
Chairman

James Shaffer  
Secretary  
County Appointee

Kevin Roukey  
Director

Tory Friedmen  
Supervisor

Spencer Scott  
Supervisor

John Muntin  
Supervisor

OPEN  
City Appointee

Lora Robb, Planner  
Trevor Lloyd, Senior Planner  
Eric Young, Senior Planner  
Washoe County Community Services Department  
Planning and Development Division  
1001 E. Ninth St., Bldg. A  
Reno, NV 89512

May 31, 2016

**Subject: May Agency Review III – Case Nos. – AB16-0002 (Hall); RZA16-001 (Pyramid Ranch Annex); TM16-005 (The Ridge at Hunter Creek); MPA16-002 and RZA16-003 (Gerlach GID)**

Lora, et al,

Thank you for providing us the May Agency Reviews III and the opportunity to review and provide comments. We have reviewed the subject proposed projects as requested and we have the following comments:

**Abandonment Case Number AB16-002 (Hall)**

The proposed project is to approve the abandonment of a 30-foot access easement of the north end of the subject property, to the benefit of the applicant. The project is located in Section 8, T22N, R19E, MDBM, APN 079-382-70, in Washoe County. The project is further located at 1282 Deerlodge Road. We have the following comments on this proposed project:

1. **General Comments** - The application does not provide enough detailed information on proposed landscaping or proposed conservation efforts with regards to installation of Best Management Practices (BMPs) during construction and after construction is complete. We recommend the County condition the approval requiring the applicant to comply with appropriate County ordinances regarding Floodplain Management that would be necessary for the project. Also that the applicant be required to coordinate with the Washoe-Storey Conservation District (WSCD) to develop an appropriate landscaping and revegetation plan.

**Regulatory Zone Amendment Case Number RZA16-001 (Pyramid Ranch Annex)**

The proposed project is to approve an amendment to the Spanish Springs Regulatory Zone Map to allow changing the Regulatory Zone from Parks and Recreation (PR) to Medium Density Suburban (MDS) on a +/- 15.5-acre portion of a +/- 20.5-acre parcel located west of Gator Swamp Park in Spanish Springs (Pyramid Ranch Estates Subdivision) The project is located in Section 26, T21N, R20E, MDBM in Washoe County (APN 532-091-09). We have the following comments on this proposed project:

1. **General Comments** – We are available to provide any coordination efforts we can with regards to conservation efforts, to the applicant once the development moves toward the housing development layout. We would urge the County to condition the approval with a requirement to utilize Low Impact Development (LID) designs for the development.
2. **Storm Water** – With regards to storm water runoff, we encourage the county to condition the approval to require the use of LID storm water collection systems that minimize sediment from entering the outlet channel. Also condition the approval requiring the applicant to coordinate with the WSCD with regards to the design and placement of the outfall structures to ensure they do not impact the channel by erosion or accretion.

**WMPA23-0008 AND  
WRZA23-0009  
EXHIBIT F**

3. Please provide us with updates to the proposed project property development as it moves forward for specific development.

**Tentative Map Case Number TM16-005 (The Ridges at Hunter Creek)**

The proposed project is to approve a 53 lot common open space subdivision on four parcels totaling 155.01 acres. The proposed project is located in portions of Sections 19 and 30, T19N, R19E, MDM at APNs 041-671-01; 041-650-02; 041-662-12; and 041-650-03 in Washoe County, Nevada. Further located south of Wood Circle and Hunters Peak Road and West Hawken Drive. We have the following comments on this proposed project.

**Supplemental Information - Item 20** – The applicant states that there are no Significant Hydrological Resources subject to Article 418. Although Hunter Creek is not identified on the US Fish and Wildlife National Wetlands inventory as containing wetlands. It is a tributary of the Truckee River and would be a Waters of the United States and it does contain a significant riparian and stream environment zone. And per Washoe County Development Code Article 418 states: No variance to the significant hydrologic resource standards, pursuant to Article 804, Variances, shall be processed or approved. Refer to Section 110.418.40 Modification of Standards. In determining the location of the above-designated streams, staff shall use:

(1) Published United States Geological Service (USGS) topographic maps, either in 7.5 minute or 15 minute series, to assist in the interpretation of location of significant hydrologic resources.

(2) A determination of the location of a perennial stream resulting from a delineation of wetlands and/or waters of the United States made by the United States Army Corps of Engineers (USACE) under the provisions of Section 404 of the Federal Clean Water Act, shall be considered the perennial stream crossing any parcel of land.

(3) Field survey by land surveyor or professional engineer licensed and qualified to perform a survey.

Therefore, we recommend the County condition the approval to require the applicant to prepare a Jurisdictional Determination to be submitted to the USACE for approval of the delineated waters of the U.S. and the surveyed Stream Environment Zone.

**Supplemental Information – Item 28** – The applicant states that the most appropriate revegetation seed mix and pounds per acre for this specific location will be determined and noted on the final improvement plan set for each phase of development. We recommend that the County condition the approval to require the applicant to coordinate with the Washoe-Storey Conservation District (WSCD) and the NRCS to develop and approve the final revegetation seed mix and pounds per acre.

**Supplemental Information – Item 30** – The applicant states that they have not yet had the revegetation plan reviewed by the WSCD, but goes on to state that they will be consulted prior to completion of the final improvement plans for each phase of development. We recommend that the County condition the permit to require the applicant to coordinate with the WSCD and NRCS in the development and approval of the revegetation plan. And require the applicant to provide the Letter of Approval from WSCD.

**General Comments** - We would urge the County to condition the approval with a requirement to utilize Low Impact Development (LID designs for the development.

**Master Plan Amendment Case Number MPA16-002 and Regulatory Zone Amendment Case Number RZA16-003 (Gerlach General Improvement District)**

The proposed project is to adopt by resolution an amendment to the High Desert Master Plan Map, changing the Master Plan Category from Rural @ to Suburban Residential (SR) on one parcel of +/- 9.4 acres of land and approve a resolution recommending adoption of an amendment to the High Desert Regulatory Zone Map, changing the Regulatory Zone Map from General Rural (GR) to Medium Density Suburban (MDS) on one +/- 19.4- acre parcel. The proposed project is located in Section 15, T32N, R23E MDM in Washoe County. It is further located at the North Edge of Gerlach adjacent to the existing development on Diablo Drive in the northeast corner formed by the intersection of Diablo Drive and Main Street.

This project is now located within the jurisdictional boundaries of the Vya Soil and Conservation District.  
Contact: Lani Estill, President, 221 West 8th Street, Alturas, California 96101  
**Phone:** (755) 333-0882.

These are our comments and recommendations for the subject projects. We appreciate the opportunity to provide comments and recommendations on projects that may have impacts on our natural resources. Should you have any further questions please contact Kevin J. Roukey by phone at 775-232-1571 or email [kevinjr\\_51@att.net](mailto:kevinjr_51@att.net).

Sincerely,

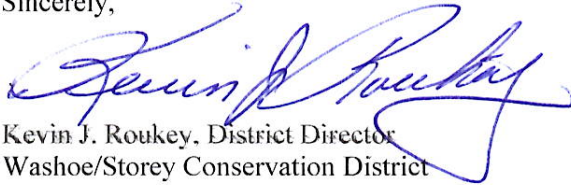
A handwritten signature in blue ink, appearing to read "Kevin J. Roukey". The signature is fluid and cursive, with a large loop at the end.

Kevin J. Roukey, District Director  
Washoe/Storey Conservation District



From: Stark, Katherine  
Sent: Tuesday, June 07, 2016 3:01 PM  
To: Lloyd, Trevor  
Cc: Stark, Katherine; Emerson, Kathy  
Subject: FW: May Agency Review Memo III, Item 3 (TM16-005)

Follow Up Flag: Follow up  
Flag Status: Flagged

Hi Trevor,

Please see the below email from Rebecca Palmer (State Historic Preservation) regarding TM16-005.

Thanks,

Katy Stark

From: Rebecca Palmer [mailto:rlpalmer@shpo.nv.gov]  
Sent: Tuesday, June 07, 2016 2:56 PM  
To: Stark, Katherine  
Subject: May Agency Review Memo III, Item 3 (TM16-005)

Katy,

I have reviewed the archaeological inventory “Archaeological Inventory of Approximately 140 Acres for the Hunter Creek trails Project, Reno, Washoe County (WCRM Report No. 05-R-67)(Lennon, 2005). While this inventory does not exactly match the proposed development, the two regionally significant resources, the Hunter Creek Ditch and the Steamboat Ditch, do not appear to be in the project area and will not likely be adversely affected by the project.

Regards,

Rebecca Lynn Palmer  
State Historic Preservation Officer  
901 South Stewart Street  
Carson City NV 89701  
(phone) 775.684.3443  
please note my email is: rlpalmer@shpo.nv.gov

1355 Capital Blvd. • P.O. Box 30013 • Reno, NV 89520-3013  
P 775.834.8080 • F 775.834.8003

May 13, 2016

Mr. Ranson Webster  
RIDGES DEVELOPMENT, INC.  
4345 Eagle Valley Circle  
Reno, NV. 89519

RE: Discovery: The Ridges at Hunter Creek, Phase II Discovery  
TMWA PLL#: 16-4930  
APN#: 041-662-01, -05, -12, and 041-650-03

Dear Mr. Webster,

Pursuant to your request, Truckee Meadows Water Authority (TMWA) has completed its Discovery for the above referenced project, also referred to as The Ridges at Hunter Creek, Phase II Discovery, TMWA PLL#: 16-4930 for APNs 041-662-01, -05, -12, and 041-650-03.

Enclosed please find two internal memoranda from TMWA's Engineering and Water Rights Departments detailing their findings. Should you have any questions after reviewing the enclosures, please feel free to contact me at (775) 834-8012 or my email at [kmeyer@tmwa.com](mailto:kmeyer@tmwa.com).

Thank you for the opportunity to serve your discovery and future project development needs.

Sincerely,



Karen L. Meyer  
New Business Project Coordinator

Enclosures

1355 Capital Blvd. P.O. Box 30013 Reno, NV 89520-3013  
775.834.8080 775.834.8003

May 9, 2016

To: Karen Meyer

Thru: Scott Estes *SJE*

From: Holly Flores *HMF*

**RE: The Ridges at Hunter Creek Phase II Discovery**

**Purpose:**

Conduct a high level engineering analysis to determine the least cost major TMWA water facility requirements and preliminary cost estimate necessary to provide water service to the proposed project.

**Preliminary Water Facility Requirements and Cost Estimates:**

The estimated cost for water facility charges and major facilities associated with this project is approximately \$900,685. These costs are summarized in the table below.

**Table 1: Estimated Major Water Facility Costs**

| Facility Description                 | Quantity | Unit    | Unit Cost | Total Cost       | Comments                          |
|--------------------------------------|----------|---------|-----------|------------------|-----------------------------------|
| Pressure Reducing Stations           | 4        | each    | \$75,000  | \$300,000        | Estimated                         |
| Emergency Tie to Eagles Nest         | 1,710    | feet    | \$120     | \$205,200        | 8-inch DI main tie                |
| Supply and Treatment Facility Charge | 95       | per gpm | \$4,163   | \$395,485        | Rate Schedule WSF                 |
| <b>Estimated Cost</b>                |          |         |           | <b>\$900,685</b> | 2016 planning level estimate only |

Note: Per the 2006 annexation agreement, developers are responsible for extending an estimated 8-inch main from The Ridges to a point near the intersection of Sharps Road and Sharps Circle in the Eagles Nest area of the Caughlin Ranch development including securing and transferring all required easements and rights-of-way.

**Discussion:**

Location:

The proposed development is located near the intersection of Hunters Peak Road and Hunter Falls Court in Washoe County, Nevada on APNs 041-650-02, 041-650-03, 041-662-12 and 041-671-01. The project consists of 50 single-family custom lots on approximately 155 acres and is within TMWA's retail water service territory. A site map by Wood Rodgers is attached for reference.

*Truckee Meadows Water Authority is a not-for-profit, community-owned water utility, overseen by elected officials and citizen appointees from Reno, Sparks and Washoe County.*

Estimated Project Demands:

The estimated domestic maximum day demand for the project is approximately 95 gpm assuming average one acre lot sizes and no separate potable irrigation.

Points of Connection:

The points of connection will be to Hunters Peak Road, Hunter Falls Court and Sharps Road as shown on the TMWA master plan exhibit for work order 05-1916-1 dated July 2, 2007. The master plan facilities are partially constructed including the Ridges Pump Station and Ridges Tank and several pressure reducing stations. An exhibit showing existing facilities in the area is attached as well.

Elevation Limits of Service:

The limit of service of the existing Ridges Tank is approximately 5,300 feet in elevation. Lots with house pads above 5,310 feet in elevation will require privately owned booster pumps and pressure tanks. In addition, pressure reducing stations will be required at approximately 5,200 feet, 5,074 feet and one along the Sharps Road main tie resulting in approximately four required due to street layout and to make the Caughlin Ranch Development connection identified in the annexation agreement and shown on the 05-1916-1 exhibit. Maximum service pressure limits have been reduced from 125 psi to 100 psi resulting in more pressure reducing stations required since the original master plan.

**Assumptions:**

1. This preliminary study was based on information provided by Wood Rodgers in April and May 2016.
2. The water service plan is preliminary and subject to change.
3. Privately owned individual pressure regulating valves will be installed by the builder per TMWA design standards and the Uniform Plumbing Code.
4. The estimated maximum day demand for the project is approximately 95 gpm based on one acre average lot sizes with no separate potable irrigation. Actual demands will be determined at the time of service.
5. TMWA plans to reevaluate and possibly revise the maximum day demand calculations for all usage types within the next twelve months as part of the Water Facility Plan Update.
6. Fire flow requirements were not submitted with this project. Therefore, the maximum fire flow requirement was assumed to be 1,500 gpm to 2,000 gpm for two hours for single-family development. The actual fire flow requirements will be set by the governing fire authority.
7. Facility requirements were based on the estimated maximum day demand and fire flow requirements. Changes in demand or required fire flow rates will affect the facility requirements and in turn the cost estimates included herein.
8. All cost estimates are preliminary and subject to change. Actual costs will be determined at the time of application for service.
9. This estimate does not include the cost of onsite facilities, water rights for the project, nor contribution to the water meter retrofit fund.
10. The ultimate water facility plan proposed by the Truckee Meadows Water Authority must be reviewed for compliance with state and local codes and regulations and approved by the health authority prior to service.
11. Dead ends must be eliminated and a looped water system designed, to the extent possible, per NAC 445A regulations. The health authority may require changes to the enclosed water facility plan that may in turn affect the included cost estimates.

**Conclusion:**

The Truckee Meadows Water Authority is agreeable to supplying water service to the project, subject to the applicant satisfying certain conditions precedent, including, without limitation, the dedication of water resources, approval of the water supply plan by the local health authority, the execution of a Water Service Agreement, payment of fees, and the construction and dedication of infrastructure and easements in accordance with our rules and tariffs.

Review of conceptual site plans by the Truckee Meadows Water Authority does not constitute an application for service, nor implies a commitment by the Truckee Meadows Water Authority for planning, design or construction of the water facilities necessary for service. The extent of required off-site and onsite water infrastructure improvements will be determined by the Truckee Meadows Water Authority upon receiving a specific development proposal or complete application for service and upon review and approval of a water facilities plan by the health authority. Because the NAC 445A water system regulations are subject to interpretation, the Truckee Meadows Water Authority cannot guarantee that a subsequent water facility plan will be approved by the health authority or that a timely review and approval of the project will be made. The applicant should carefully consider the financial risk associated with committing resources to their project prior to receiving all required approvals. After submittal of a complete application for service, the required facilities, the cost of these facilities, which could be significant, and associated fees will be estimated and will be included as part of the Water Service Agreement necessary for the project. All fees must be paid to the Truckee Meadows Water Authority prior to water being delivered to the project.

Please call me at (775) 834-8026 if you have questions or need more information.

/hmf

cc: Steve Strickland, P.E., Wood Rodgers  
File: 16-4930

Attachments: April 2016 Site Map by Wood Rodgers  
TMWA Master Plan Exhibit July 2007, Work Order 05-1916-1  
TMWA Distribution System Exhibit – Existing Facilities

# OFFICIAL NOTICE OF PUBLIC HEARING

DATE: June 24, 2016

You are hereby notified that the **Washoe County Planning Commission** will conduct a public hearing at the following time and location:

**6:30 p.m., Tuesday, July 5, 2016**

**County Commission Chambers, 1001 East Ninth Street, Reno, NV 89520**

**Tentative Map Case Number TM16-005 (The Ridges at Hunter Creek)** – Hearing, discussion, and possible action to approve the merger and re-subdivision of four parcels totaling 155.01 acres into a 53 lot common open space subdivision.

- Applicant/Owner: Ridges at Hunter Creek LLC. and Ridges Development Inc.
- Location: South of Woodchuck Circle and Hunters Peak Road and West of Hawken Drive
- Assessor's Parcel Numbers: 041-671-01, 041-650-02, 041-662-12 & 41-650-03
- Parcel Size: 155.01 acres
- Master Plan Category: Suburban Residential (SR), Rural Residential (RR) and Rural(R)
- Regulatory Zone: General Rural (GR), Low Density Suburban (LDS) and High Density Rural (HDR)
- Area Plan: Southwest Truckee Meadows Area Plan
- Citizen Advisory Board: West Truckee Meadows
- Development Code: Article 408, Common Open Space Developments; Article 424, Hillside Development; and, Article 608, Tentative Subdivision Maps
- Commission District: 1 – Commissioner Berkbigler
- Section/Township/Range: Section 19 & 30, T19N, R19E, MDM, Washoe County, NV
- Staff: Trevor Lloyd, Senior Planner  
Washoe County Community Services Department  
Planning and Development Division
- Phone: 775.328.3620
- E-mail: [tlloyd@washoecounty.us](mailto:tlloyd@washoecounty.us)

As an owner of property in the vicinity, you are invited to present testimony relative to these matters. To access additional information about this item, please visit our website at [www.washoecounty.us/comdev/](http://www.washoecounty.us/comdev/), choose **Boards and Commissions**, then **Planning Commission**, click on **2016** and choose the meeting date. A staff report related to this public hearing will be posted on Friday, four days prior to the meeting.

**UTILITY SERVICE FEASIBILITY REPORT  
(SANITARY SEWER, STORM DRAIN, & WATER)**

**FOR**

**THOMPSON FAMILY TRUST  
(APN 041-650-04 AND 041-650-05)**

Prepared for:

DAVID J AND CLAUDIA THOMPSON  
THOMPSON FAMILY TRUST  
P.O. BOX 382  
GLENBROOK, NV 89413



**SUMMIT ENGINEERING CORPORATION**

5405 Mae Anne  
Reno, Nevada 89523  
(775) 747-8550

JOB # 1-31143

September 2023



**WMPA23-0008 AND  
WRZA23-0009  
EXHIBIT F**

9-6-23

**TABLE OF CONTENTS**

Introduction ..... 1  
Study Area and Previous Studies ..... 1  
Sanitary Sewer ..... 4  
Storm Drainage ..... 4  
Water Service ..... 5  
Conclusion ..... 6  
Limitations ..... 7

**List of Figures**

Figure 1 – Vicinity Map ..... 2  
Figure 2 – Conceptual Site and Utility Plan ..... 6  
Figure 3 – Conceptual Grading Plan ..... 7

**Appendix**

Assessor Map 041-65 ..... 9  
TMWA Discovery – Thompson Family Trust ..... 10



## **INTRODUCTION**

The following is a preliminary report regarding the feasibility of providing adequate sanitary sewer service, storm drainage facilities, and water service to support future development on the Thompson Family Trust parcels known as APN 041-650-04 and 041-650-05. These two parcels are located within Washoe County. The nearest existing roads to the project site, existing as of the date of this report, are Woodchuck Circle (paved up to Stag Ridge Court), and Hunters Peak Road (aggregate base only), both constructed with The Ridges at Hunter Creek Phase 1 (refer to Figure 1 Vicinity Map).

The conceptual development plan consists of 8 custom single-family lots to be located at the end of a proposed cul-de-sac accessed from street improvements shown on The Ridges at Hunter Ridge Phase II Tentative Subdivision Map (Case No. TM16-005) and prepared by Wood Rodgers in 2016. An approved development agreement between Washoe County and Ridges Development Inc./Ridges at Hunter Creek ITI LLC, regarding The Ridges at Hunter Creek Phase II (RHC2), extends the approval until July of 2022 (ref. Doc. 5066850, recorded 8/19/20, on file at Washoe County). If a final map is not approved over a portion of the project prior to July 5 of 2022, then the approval of the tentative map expires.

## **STUDY AREA AND PREVIOUS STUDIES**

The area of the proposed development has been previously studied as part of past downstream developments. The following is a list of some of the documents in the area that were referenced for this report:

- (1) The Ridges at Hunter Creek Ph1 Construction & Backbone Infrastructure for The Ridges at Hunter Creek Phase 1 and II, and the Edge and The Point at Hunter Creek Technical Hydrology & Drainage Report Volume I and Volume II Technical Appendix, prepared by Jeff Codega Planning and Design Inc. dated January 23, 2008.

In addition to the above listed reports the following were referenced for this study:

- (1) Washoe Co. Development Code – Article 420 Storm Drainage Standards
- (2) Washoe Co. Development Code – Article 422 Water and Sewer Resource Requirements
- (3) TMWA Discovery for Thompson Family Trust, dated 1/25/22
- (4) Civil Improvement Plans for The Ridges at Hunter Creek Phase 1, prepared by Jeff Codega Planning/Design Inc., dated 2008
- (5) The Ridges at Hunter Creek Ph II Tentative Subdivision Map, Case No. TM16-005, prepared by Wood Rodgers Inc., dated 5/16/16.
- (6) The Ridges at Hunter Creek Ph II Unit 1 Civil Improvement Plans, prepared by Wood Rodgers Inc., dated 5/3/22.
- (7) Technical Drainage Report for Ridges at Hunter Creek Ph II Unit 1, prepared by Wood Rodgers Inc., dated 10/14/19.
- (8) Sanitary Sewer Report for Ridges at Hunter Creek Ph II Unit 1, dated 10/14/19, prepared by Wood Rodgers Inc., dated 11/14/19.
- (9) Civil Improvement Plans for Juniper Trails Unit 7-A, prepared by Codega Fricke, dated April 1990.

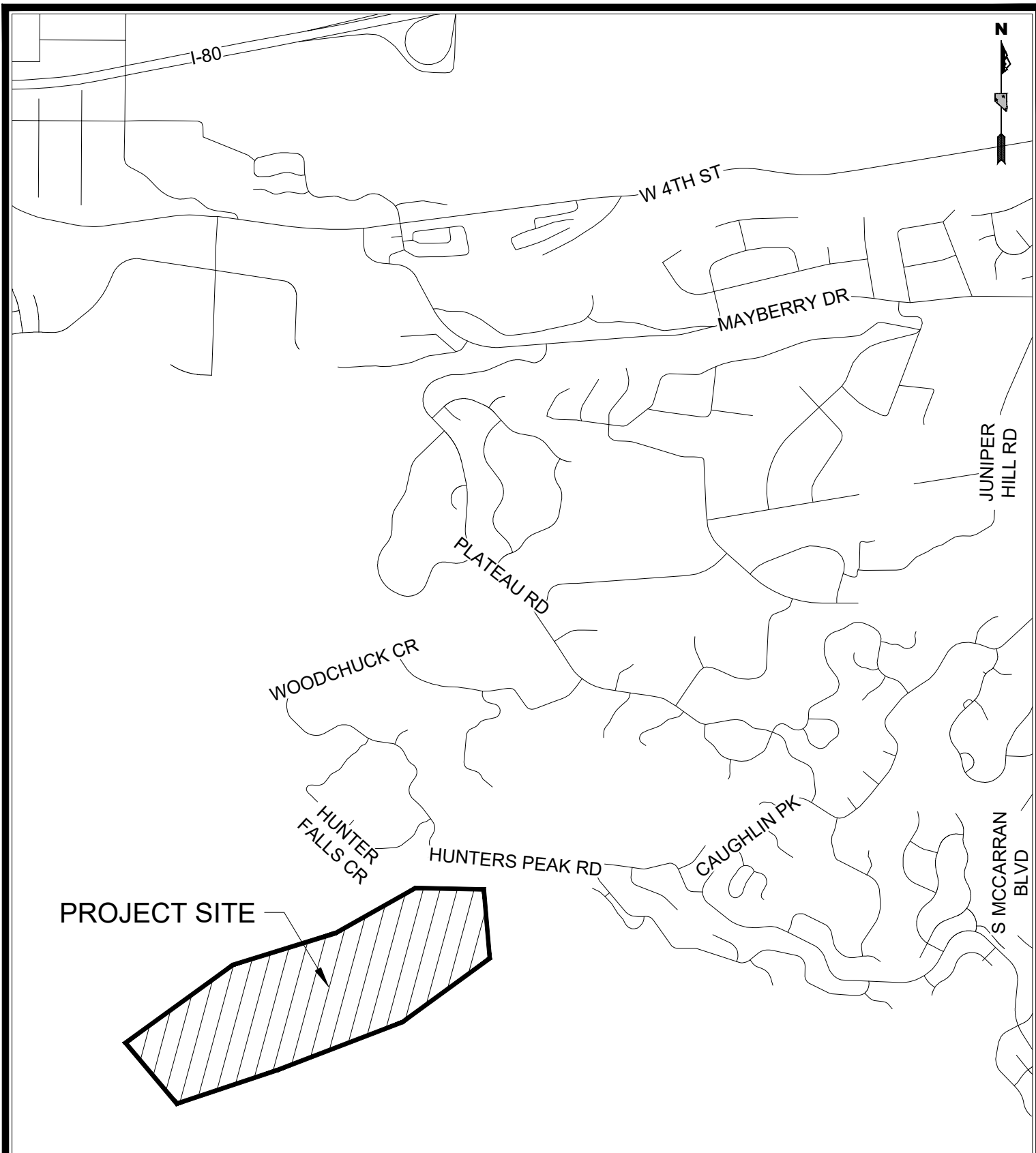

**FIGURE #1**  
**VICINITY MAP**  
**THOMPSON FAMILY TRUST**

NOT TO SCALE

---

Copyright SUMMIT ENG 2022

**SUMMIT** ENGINEERING CORPORATION  
 5405 MAE ANNE AVENUE, RENO, NV. 89523  
 PHONE:(775) 747-8550 FAX:(775) 747-8559

SHEET  
 1  
 OF  
 1

N:\DWGS\J31143\_ThompsonWoodchuck\Civil\Thompson\_VicinityMap.DWG ~ 3:09 PM \* 09-AUG-2022

## **SANITARY SEWER**

The sanitary sewer service for the proposed Thompson Family Trust development will most likely be provided via public sanitary sewer mains that are to be installed with the Ridges at Hunter Creek Phase II development (RHC2) along with some new on-site sewer improvements. The Ridges at Hunter Creek Phase II (RHC2) Tentative Map (TM16-005), Preliminary Utility Plan U-1 and U-2, provides a nice overview of the proposed public sanitary sewer mains that will be constructed with that project, that is adjacent to the Thompson Family Trust site. The RHC2 project tentative map plans depict sewer facilities being installed in Hunter Falls Circle and Hunter Peak Road, located directly north of the proposed Thompson Family Trust development. The RHC2 development recorded a 21-lot final map, The Ridges at Hunter Creek Phase II Unit 1 (TM5495), over a portion of the project, which includes construction of public sewer improvements. If the developer of RHC2 proceeds with construction of Unit 1 as well as a final map on the balance of the project, public sewer would be extended up Hunter Falls Circle from Hunter Peak Road, which would be the most likely point of connection for the Thompson Family Trust development. The public sewer facilities to be constructed by RHC2, within Hunter Peak Road will continue easterly and tie into an existing 8" public sanitary sewer main located in the existing county maintenance access road off of Caughlin Parkway previously constructed with the Juniper Trails 7-B Subdivision (TM 2688).

A new 8" diameter PVC sanitary sewer main would be installed with the proposed cul-de-sac to serve the proposed Thompson Family Trust development. This future main would extend to the north and tie into the RHC2 sanitary sewer main in Hunter Falls Circle, just east of Lot 43. It is anticipated that the proposed sewer mains, that are to be built with the RHC2, will have sufficient capacity to convey the sewer flow generated by the additional 8 lots of the Thompson Family Trust development. However, a sanitary sewer capacity analysis of the existing downstream sanitary sewer facilities is not within the scope of this report and would be appropriate to do with any Tentative Map effort on this development to confirm capacity. Based on the approved RHC2 Tentative Map Plans, and the presence of existing downstream sanitary sewer facilities, providing sewer service via a traditional public gravity sewer collection system for the proposed 8 lots of the Thompson Family Trust development appears feasible. The proposed sanitary sewer system would include private sanitary sewer laterals to each lot, an 8" minimum PVC sanitary sewer main, and several new sanitary sewer manholes. Refer to Figure #2 for the conceptual sanitary sewer main, laterals, manholes, and connection point to the public sanitary sewer within The Ridges at Hunter Creek Phase II development. All proposed sanitary sewer facilities would need to be designed and constructed in accordance with all applicable Washoe County Standards.

## **STORM DRAIN**

Existing topography within the proposed Thompson Family Trust development, primarily slopes steeply down towards the east, and towards the existing Hunter Peak Road, constructed with The Ridges at Hunter Creek Phase 1 (TM4833). The Thompson Family Trust development site occupies a portion of a larger watershed that drains stormwater toward an existing 60" diameter headwall and culvert under Hunter Peak Road. The existing 60" diameter culvert under Hunters Peak Road discharges to another existing 60" diameter headwall and culvert a little further downstream to the northeast, followed by a dual 4x6 reinforced concrete box culvert a little further northeast crossing under Hunters Peak Road again. As indicated by the Ridges at Hunter Creek

Phase 1 Hydrology and Drainage Report, the intent of these existing downstream culverts is to pass the off-site drainage from the large watershed to the south, through that site and perpetuate it downstream.

The conceptual development plan for the Thompson Family Trust, includes a schematic layout of the anticipated storm drain system. The anticipated on-site drainage facilities would likely consist of storm drain mains, inlets, lateral piping, manholes, headwalls, an on-site detention basin and one or more engineered drainage channels. The storm drain system would be designed to collect runoff from the large offsite watershed to the south and route it through the site via a proposed engineered drainage channel, inlet or headwall structure, and proposed piping. The proposed storm drain system would route runoff from the large off-site drainage area through the site and discharge it to the northeast of the site near the existing 60" diameter headwall and culvert upstream of Hunters Peak Road, maintaining the existing predevelopment drainage pattern. Refer to Figure #2 for the conceptual storm drain system layout and storm drain easements and refer to Figure #3 for elevations at drop inlets, manholes, and headwalls.

The Thompson Family Trust development would result in an increase in runoff discharged from the site due to the increase in impermeable surfaces, such as paved areas and building roofs. In order to mitigate these proposed increases, and maintain runoff discharged downstream to existing levels, some stormwater detention will be required. A separate storm drain collection system would collect runoff from the cul-de-sac and route it to a proposed on-site detention basin. The proposed on-site detention basin would be used to detain the increase in runoff from the added impermeable surfaces from the development of the site. The proposed detention basin would be designed with an outlet structure that would limit the flow to at or below existing levels. The proposed detention basin would also be designed with an emergency overflow structure to prevent the detention basin from overtopping. Downstream of the outlet of the proposed detention basin is a 24" culvert, which conveys the runoff to an existing detention basin, all of which were constructed with The Ridges at Hunter Creek Phase 1 Subdivision project.

Constructing a proposed on-site detention basin upstream from the existing 24" diameter culverts under Hunters Peak Road appears feasible based on preliminary review of grading plans from the Ridges at Hunter Creek Phase 1. Modification of the existing drainage channel between the outlet of the proposed on-site detention basin and the existing 24" culvert would likely occur. Modifications would likely include grading in the area of the outlet of the proposed detention basin, revegetation, erosion control, riprap erosion protection, perhaps modifying the existing drainage channel. Modifications would also likely include construction of a maintenance access to the detention area for vehicles and equipment. Any modifications on the adjacent property would require easements for drainage, construction, and maintenance access from the adjacent property owner.

As an alternative to providing on-site detention within the Thompson Family Trust property, it may be feasible to modify one of the existing or proposed downstream detention areas constructed within the Ridges at Hunter Creek project. This would require additional analysis and would likely require easements and an agreement with the adjacent developer of the Ridges at Hunter Creek. This option also appears feasible.

A detailed drainage analysis would be required along with any preliminary design of modifications or improvements to the existing downstream drainage facilities. All proposed storm drainage facility design and construction would need to comply with all applicable Washoe County Standards.

### **WATER SERVICE**

The Thompson Family Trust site is listed as being with the TMWA Retail Area (refer to TMWA Water Service Areas by Purveyor Map, January 2021). The applicant engaged TMWA to prepare a Water Discovery to estimate the following: (1) improvements that would be required in order to serve the proposed development, (2) an initial estimate of the water rights that would be required to be dedicated with the project, and (3) an estimate of the facility charges associated with the development. Refer to the attached TMWA Discovery for the Thompson Family Trust development included in the appendix. Refer to Figure #2 for the conceptual site layout of the TMWA water main.

### **CONCLUSIONS**

This initial assessment was focused on feasibility of service and is consistent with other similar preliminary efforts. Based on our initial analysis and very preliminary design work, it appears feasible to extend public sewer and water improvements up to the Thompson Family Trust development. It also appears feasible to design storm drain improvements to convey off-site runoff through the site, as well as collect and detain runoff from the proposed street in order to comply with current county drainage code for the Thompson Family Trust development. However, additional design work typically associated with a Tentative Map application would be required to further develop a preliminary plan.

### **LIMITATIONS**

As of the date of this report, it is unknown if the adjacent developer is going to pursue development and construction of the Ridges at Hunter Creek Ph II Unit 1 or the balance of that project and its infrastructure. The infrastructure needed to provide service to the Thompson Family Trust development requires the design, permitting, and construction of said water and sewer improvements.

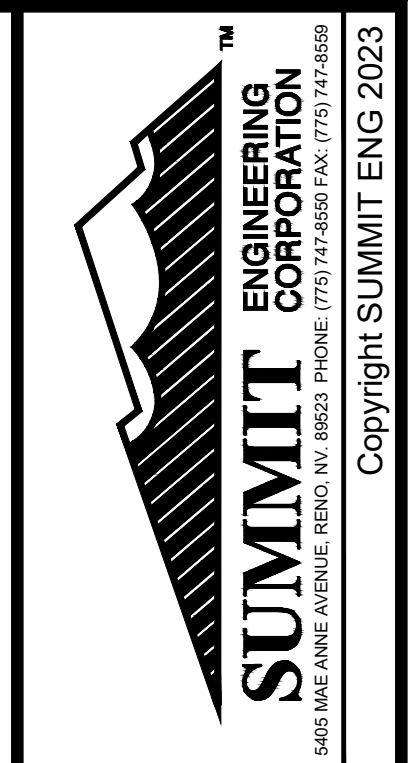
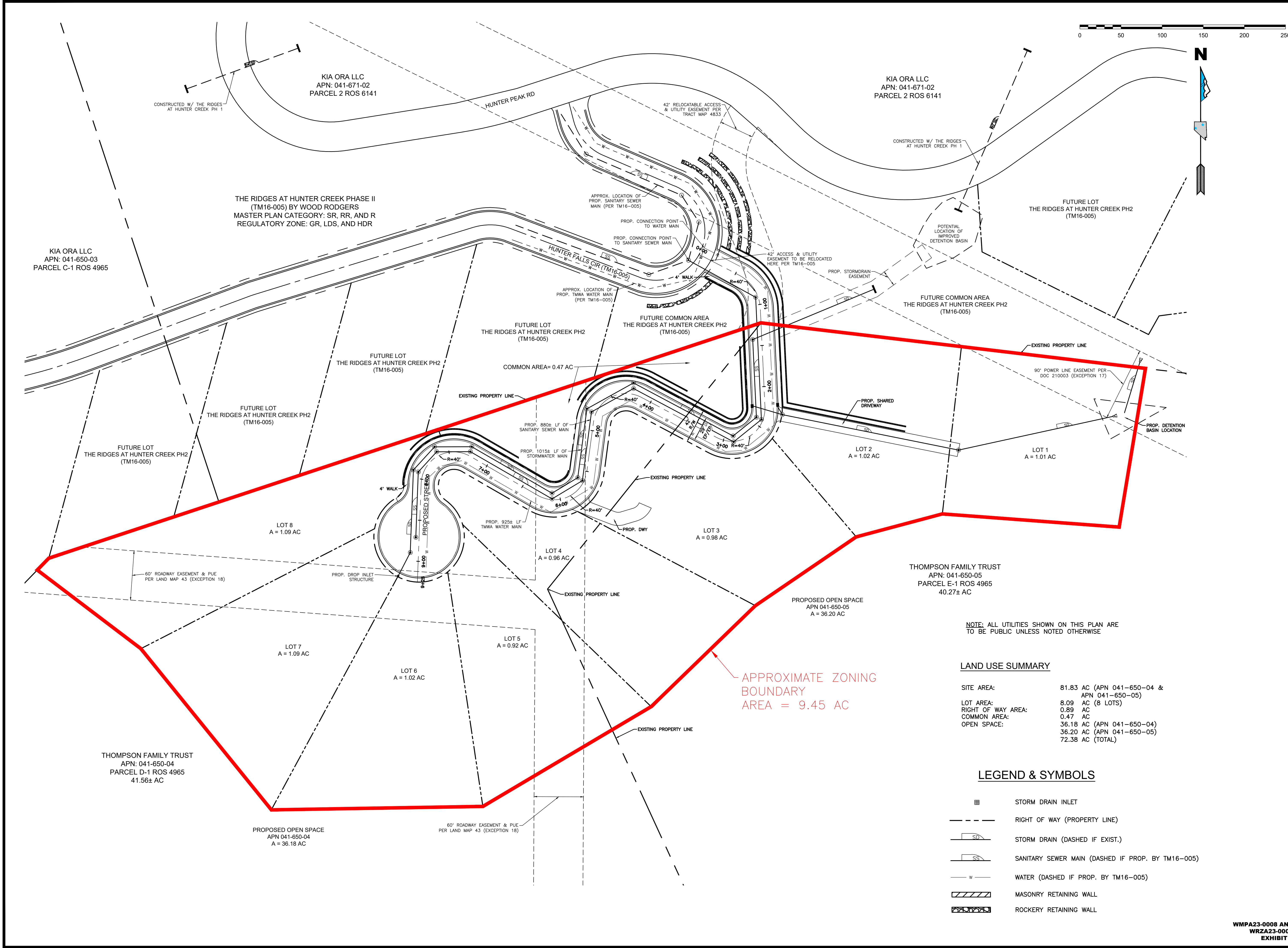

| REV. | DATE | DESCRIPTION | BY | APPD |
|------|------|-------------|----|------|
|      |      |             |    |      |

**THOMPSON FAMILY TRUST**  
**APN 041-650-04 & 041-650-05**  
**FIGURE #2 - CONCEPTUAL SITE AND UTILITY PLAN**

|              |                           |
|--------------|---------------------------|
| JOB NO:      | 31143                     |
| DRAWN BY:    | cmenefee                  |
| DESIGNED BY: | CM                        |
| CHECKED BY:  | CH                        |
| SCALE:       | HORZ: 1"=50'<br>VERT: N/A |

|                                             |                   |                         |
|---------------------------------------------|-------------------|-------------------------|
| WMPA23-0008 AND<br>WRZA23-0009<br>EXHIBIT F | SHEET<br><b>1</b> | TOTAL<br>OF<br><b>2</b> |
|---------------------------------------------|-------------------|-------------------------|

NOTE: ALL UTILITIES SHOWN ON THIS PLAN ARE TO BE PUBLIC UNLESS NOTED OTHERWISE

**LAND USE SUMMARY**

|                    |                                                                            |
|--------------------|----------------------------------------------------------------------------|
| SITE AREA:         | 81.83 AC (APN 041-650-04 & APN 041-650-05)                                 |
| LOT AREA:          | 8.09 AC (8 LOTS)                                                           |
| RIGHT OF WAY AREA: | 0.89 AC                                                                    |
| COMMON AREA:       | 0.47 AC                                                                    |
| OPEN SPACE:        | 36.18 AC (APN 041-650-04)<br>36.20 AC (APN 041-650-05)<br>72.38 AC (TOTAL) |

**LEGEND & SYMBOLS**

- STORM DRAIN INLET
- RIGHT OF WAY (PROPERTY LINE)
- STORM DRAIN (DASHED IF EXIST.)
- SANITARY SEWER MAIN (DASHED IF PROP. BY TM16-005)
- WATER (DASHED IF PROP. BY TM16-005)
- MASONRY RETAINING WALL
- ROCKERY RETAINING WALL

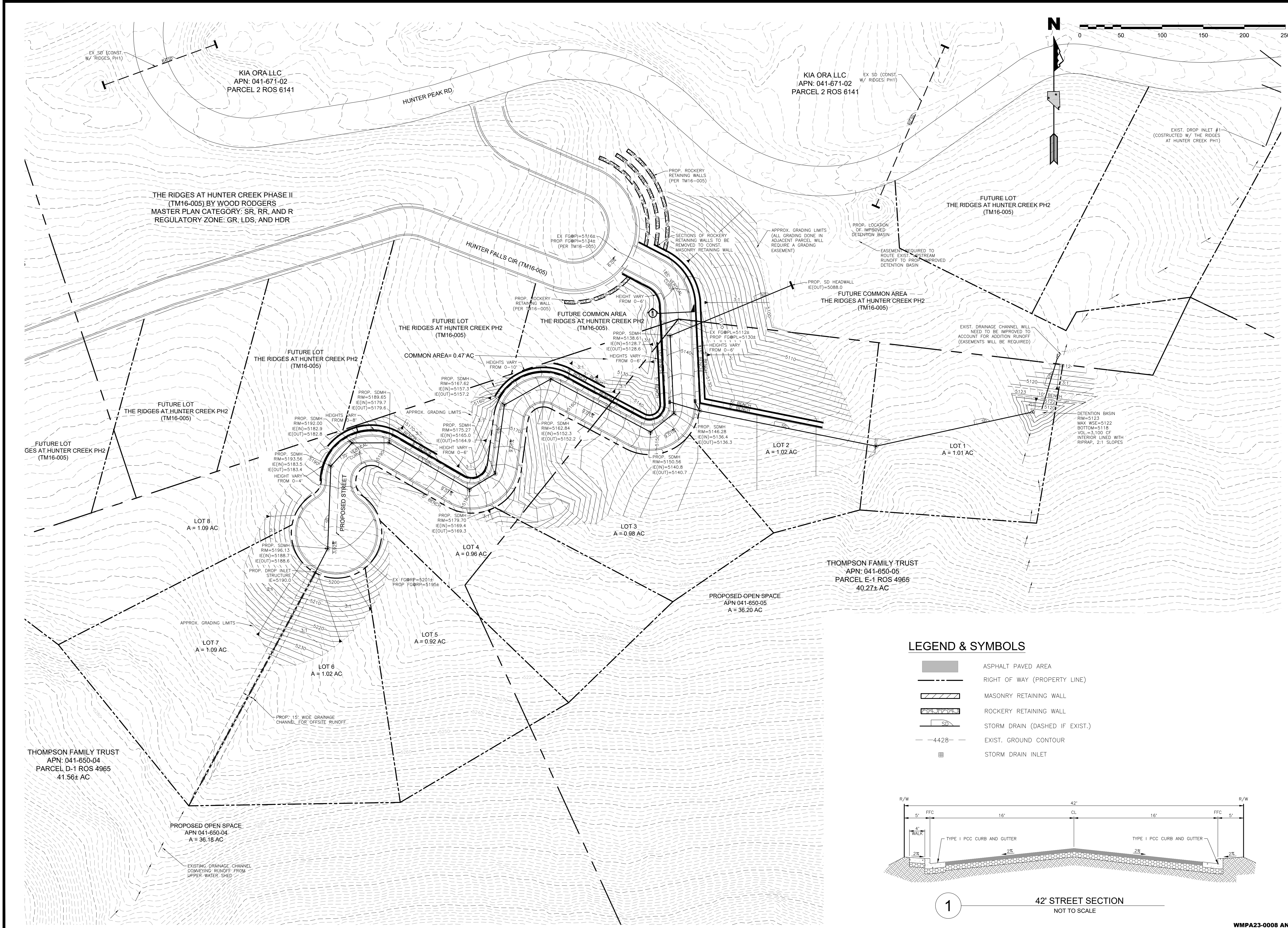

**LEGEND & SYMBOLS**

- ASPHALT PAVED AREA
- RIGHT OF WAY (PROPERTY LINE)
- MASONRY RETAINING WALL
- ROCKERY RETAINING WALL
- STORM DRAIN (DASHED IF EXIST.)
- EXIST. GROUND CONTOUR
- STORM DRAIN INLET

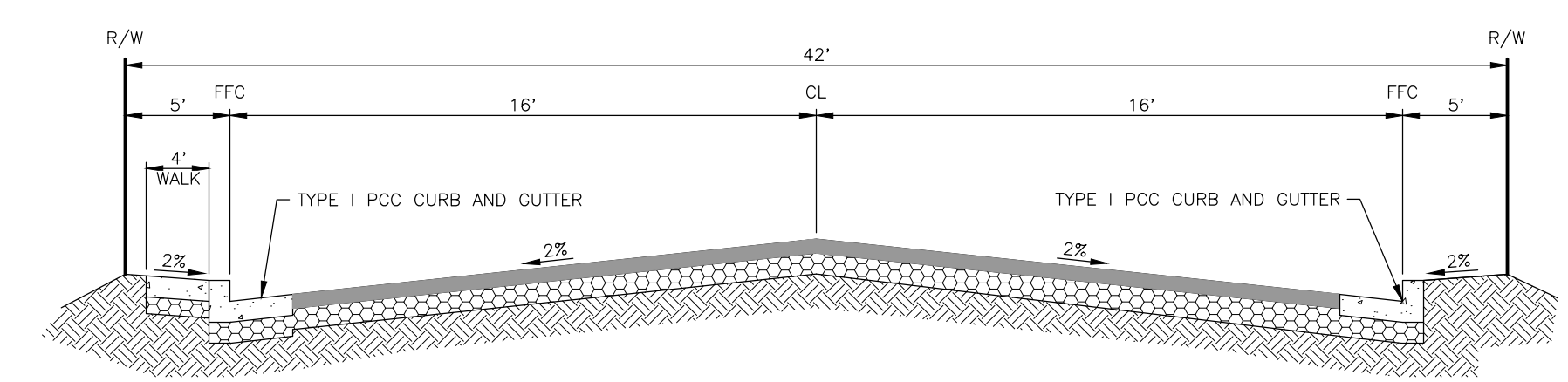

**1** 42' STREET SECTION  
NOT TO SCALE

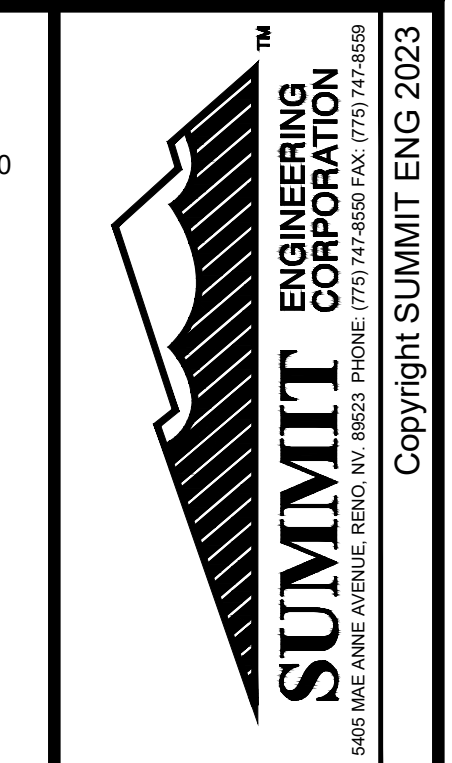

| REV. | DATE | DESCRIPTION | BY | APPD |
|------|------|-------------|----|------|
|      |      |             |    |      |

**THOMPSON FAMILY TRUST  
APN 041-650-04 & 041-650-05  
FIGURE #3 - CONCEPTUAL GRADING PLAN**

|              |                           |
|--------------|---------------------------|
| JOB NO:      | 31143                     |
| DRAWN BY:    | cmenefee                  |
| DESIGNED BY: | CM                        |
| CHECKED BY:  | CH                        |
| SCALE        | HORZ: 1"=50'<br>VERT: N/A |

|                                             |                   |                         |
|---------------------------------------------|-------------------|-------------------------|
| WMPA23-0008 AND<br>WRZA23-0009<br>EXHIBIT F | SHEET<br><b>2</b> | TOTAL<br>OF<br><b>2</b> |
|---------------------------------------------|-------------------|-------------------------|

Copyright SUMMIT ENG 2023  
 NEVADA  
 WASHOE COUNTY  
 RENO

**APPENDIX**

Assessor Map 041-65  
TMWA Discovery – Thompson Family Trust



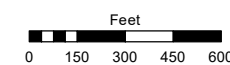

1 inch = 600 feet

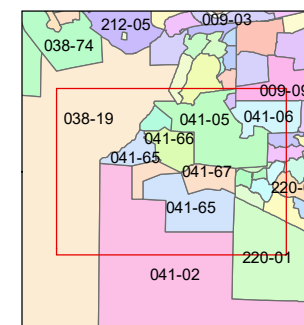
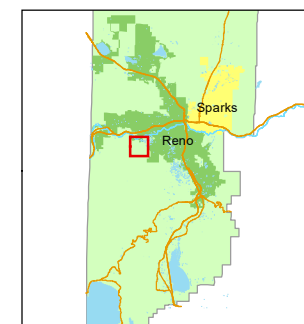

created by: CFB 10/28/2009

updated: SR 04/14/20 SR 01/14/21

area previously shown on map(s):

041-05 041-66

# PORTIONS OF S½ SECTION 19 & N½ SECTION 30, T19N - R19E

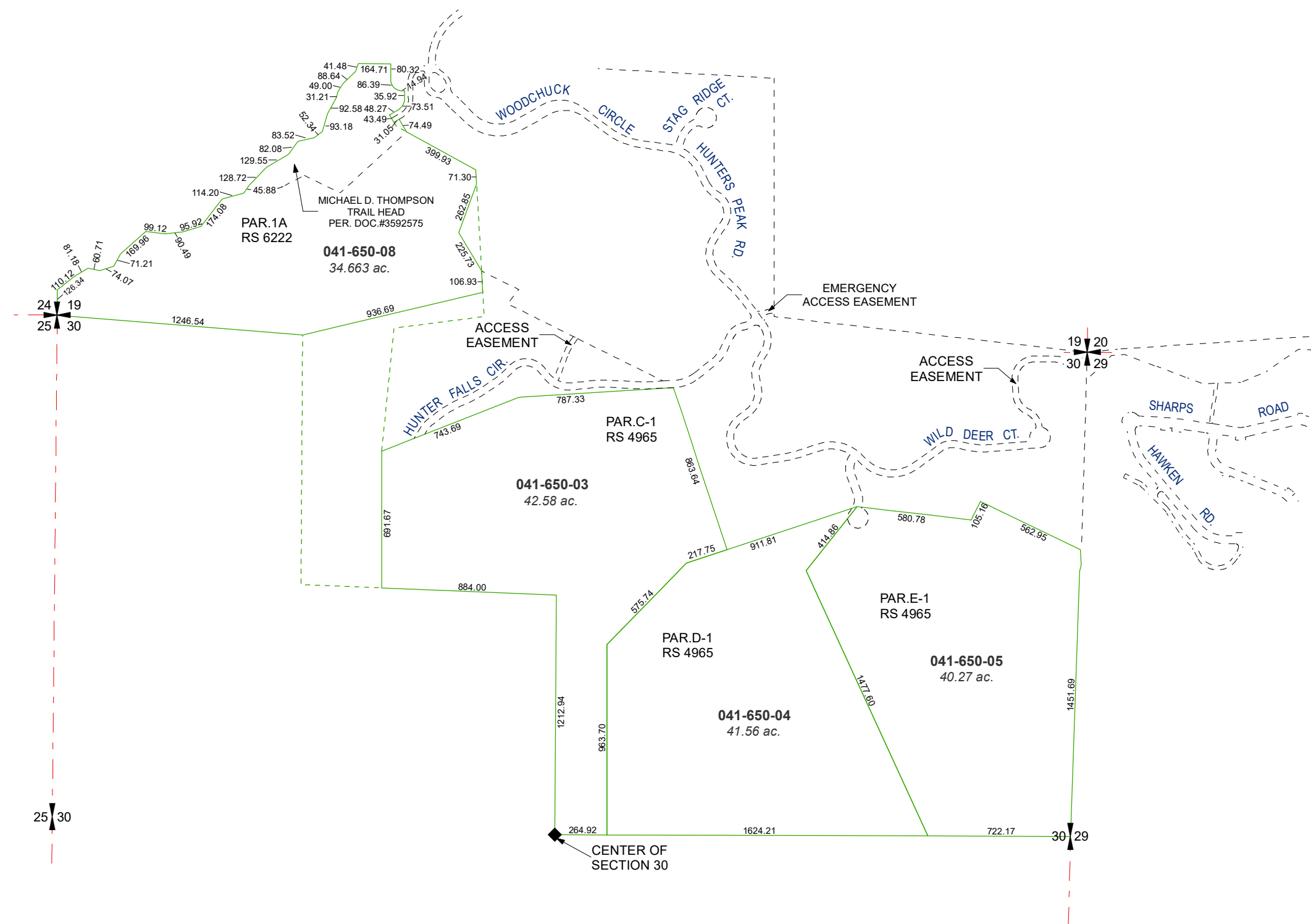



January 25, 2022

To: Nancy Raymond  
 Thru: Scott Estes *SJE*  
 From: Holly Flores *HMF*  
 RE: 22-8371 Thompson Family Trust Discovery

**Purpose:**

Conduct a high-level engineering analysis to determine the least cost major TMWA water facility requirements and preliminary cost estimate necessary to provide water service to the proposed project.

**Preliminary Water Facility Requirements and Cost Estimates:**

The estimated cost for water facility charges and major off-site facilities associated with this project is approximately \$970,266. These costs are summarized in the table below.

**Table 1: Estimated Major Water Facility Costs**

| Facility Description                 | Quantity | Unit    | Unit Cost | Total Cost       | Comments                          |
|--------------------------------------|----------|---------|-----------|------------------|-----------------------------------|
| Pressure Regulating Stations         | 2        | each    | \$75,000  | \$150,000        | Estimated                         |
| 10-inch Off-Site Main Extensions     | 3,750    | feet    | \$200     | \$750,000        | Extend from existing facilities   |
| Supply and Treatment Facility Charge | 10.1     | per gpm | \$6,957   | \$70,266         | Rate Schedule WSF                 |
| <b>Estimated Cost</b>                |          |         |           | <b>\$970,266</b> | 2022 planning level estimate only |

Note: Costs shown above will become effective January 31, 2022.

**Discussion:**

Location:

The proposed development is located south of the intersection of Hunters Peak Road and Hunter Falls Circle in Washoe County, Nevada on APNs 041-650-04 and 041-650-05. The project consists of eight large single-family custom lots on the northern 6.71-acre portion of the total 81.83 acres and is within TMWA's retail water service territory. The Record of Survey Map 4965, Conceptual Site and Utility Plan and Conceptual Grading Plan by Summit Engineering Corporation is attached for reference.

Estimated Project Demands:

The estimated domestic maximum day demand for the project is approximately 10.1 gpm based on provided lot sizes and no separate potable irrigation.

**WMPA23-0008 AND  
 WRZA23-0009  
 EXHIBIT F**

Points of Connection:

The points of connection will be to existing facilities at Hunters Peak Road and Hunter Falls Circle as shown on the attached TMWA distribution system facilities exhibit.

Major Off-Site Facility Requirements:

10-inch main extensions off-site and on-site will be required along with two pressure regulating stations as shown on the preliminary hydraulic analyses exhibit attached. The Hunter Falls Circle main extension will require an all-weather access road over the pipe at least fifteen feet wide with 6-inches of compacted base if not paved. Road costs are not estimated nor included herein.

Elevation Limits of Service and Private Booster Pump Requirements:

The limit of service of the existing Ridges Tank is approximately 5,300 feet in elevation and proposed new regulated zone approximately 5200 to 5210 feet in elevation. Lots with elevations above 5,200 feet in elevation will require privately owned booster pumps and pressure tanks. In addition, two new pressure regulating stations will be required at approximately 5,200 feet elevation to maintain customer service pressures below the 100-psi maximum.

Dead Ends and Water Main Looping Requirements:

The proposed cul-de-sac results in a dead-end water main greater than 900 feet in length which exceeds the preferred maximum 800 feet in length per the following TMWA design criteria:

1.1.06.06 Dead-end mains shall be minimized by looping mains whenever practical or where required by the Authority and/or the Health Authority. Preliminary design and layout of subdivision streets and lots should contribute to elimination of dead-end mains. The maximum length of a dead-end main shall be approximately 800 feet. All dead-end mains shall be terminated with a flush valve assembly.

1.1.06.07 Mains installed in a cul-de-sac shall run the full street length ending approximately fifteen (15) feet from the property's front edge at the end of the cul-de-sac, or five (5) feet past the last service as designated on the plans, unless they are looped. Mains installed in a cul-de-sac that is greater than eight hundred (800) feet in length shall be looped where practical.

**Assumptions:**

1. This preliminary study was based on information provided by Summit Engineering Corporation in January 2022.
2. The water service plan is preliminary and subject to change.
3. This report includes recently adopted facility charges contained in Rate Schedule WSF with an effective date of January 31, 2022.
4. Privately owned individual pressure regulating valves will be installed by the builder per TMWA design standards and the Uniform Plumbing Code.
5. The estimated maximum day demand for the project is approximately 10.1 gpm with no separate potable irrigation. Actual demands will be determined at the time of service. Fire flow requirements were not submitted with this project. Therefore, the maximum fire flow

- requirement was assumed to be 2,000 gpm for two hours for single-family development. The actual fire flow requirements will be approved by the governing fire authority.
6. Facility requirements were based on the estimated maximum day demand and fire flow requirements. Changes in demand or required fire flow rates will affect the facility requirements and in turn the cost estimates included herein.
  7. All cost estimates are for major off-site facilities and WSF charges only, are preliminary and subject to change. Actual costs will be determined at the time of application for service.
  8. This estimate does not include the cost of on-site facilities including water mains, water rights for the project, nor the Water Resource Sustainability Fee.
  9. The ultimate water facility plan proposed by the Truckee Meadows Water Authority may be reviewed for compliance with state and local codes and regulations and approved by the health authority prior to service.
  10. Dead ends must be eliminated, and a looped water system designed, to the extent possible, per NAC 445A regulations. The health authority may require changes to the enclosed water facility plan that may in turn affect the included cost estimates.

**Conclusion:**

The Truckee Meadows Water Authority is agreeable to supplying water service to the project, subject to the applicant satisfying certain conditions precedent, including, without limitation, the dedication of water resources, approval of the water supply plan by the local health authority, the execution of a Water Service Agreement, payment of fees, and the construction and dedication of infrastructure and easements in accordance with our rules and tariffs.

Review of conceptual site plans by the Truckee Meadows Water Authority does not constitute an application for service, nor implies a commitment by the Truckee Meadows Water Authority for planning, design, or construction of the water facilities necessary for service. The extent of required off-site and on-site water infrastructure improvements will be determined by the Truckee Meadows Water Authority upon receiving a specific development proposal or complete application for service and upon review and approval of a water facilities plan. After submittal of a complete application for service, the required facilities, the cost of these facilities, which could be significant, and associated fees will be estimated and will be included as part of the Water Service Agreement for the project. All fees must be paid to the Truckee Meadows Water Authority prior to water being delivered to the project.

Please call me at (775) 834-8026 if you have questions or need more information.

/hmf

cc: Danny Rotter  
Colin Hayes, P.E., Summit Engineering Corporation  
File: 21-8371

Attachments: Record of Survey Map 4965 by Jeff Codega Planning/Design Inc.  
Conceptual Site and Utility Plan by Summit Engineering Corp  
Conceptual Grading Plan by Summit Engineering Corp  
Preliminary Demand Calculations  
TMWA Distribution System Exhibit – Existing Facilities  
TMWA Hydraulic Analyses Exhibit – Preliminary Facility Plan

**SURVEYOR'S CERTIFICATE**

I, DAN ASIKAINEN, A PROFESSIONAL LAND SURVEYOR LICENSED IN THE STATE OF NEVADA, CERTIFY THAT:

1. THIS PLAT REPRESENTS THE RESULTS OF A SURVEY CONDUCTED UNDER MY SUPERVISION AT THE INSTANCE OF RIDGES DEVELOPMENT INC. AND THE DURKEE FAMILY TRUST AND DAVID J. THOMPSON AND CLAUDIA ANN THOMPSON FAMILY TRUST, DATED JUNE 1, 2004
2. THE LAND SURVEYED LIES WITHIN THE SOUTH ONE-HALF OF SECTION 19 AND THE NORTH ONE-HALF OF SECTION 30, TOWNSHIP 19 NORTH, RANGE 19 EAST, M.D.M. COUNTY OF WASHOE, AND THE SURVEY WAS COMPLETED IN JULY 2006.
3. THIS PLAT COMPLIES WITH APPLICABLE STATE STATUTES OF THIS STATE AND ANY LOCAL ORDINANCES IN EFFECT ON THE DATE THAT THE SURVEY WAS COMPLETED, AND THE SURVEY WAS CONDUCTED IN ACCORDANCE WITH CHAPTER 625 OF THE NEVADA ADMINISTRATIVE CODE.
4. THE MONUMENTS DEPICTED ON THE PLAT ARE OF THE CHARACTER SHOWN, OCCUPY THE POSITIONS INDICATED, AND ARE OF SUFFICIENT NUMBER AND DURABILITY.
5. THIS MAP IS NOT IN CONFLICT WITH THE REQUIREMENTS OF NRS 278.010 TO 278.630, INCLUSIVE, AND NO NEW LOTS ARE BEING CREATED.
6. ALL CORNERS AND ANGLE POINTS OF THE ADJUSTED BOUNDARY LINE HAVE BEEN DEFINED BY MONUMENTS OR WILL BE OTHERWISE DEFINED ON A DOCUMENT OF RECORD AS REQUIRED BY NRS 625.340.

DAN ASIKAINEN  
PLS 3318

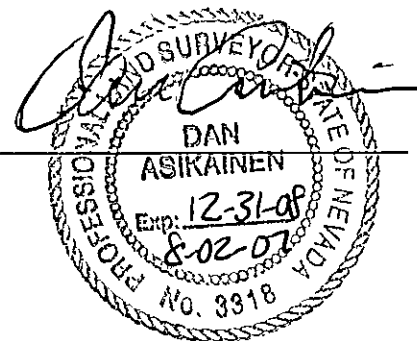

**OWNER'S CERTIFICATE**

I, THE UNDERSIGNED OWNER OF THE AFFECTED PARCELS AS SHOWN ON THIS MAP DOES HEREBY STATE:

1. I HAVE EXAMINED THIS PLAT AND APPROVE AND AUTHORIZE ITS RECORDING;
2. I AGREE TO EXECUTE THE REQUIRED DOCUMENTS CREATING ANY EASEMENT WHICH IS SHOWN HEREON;
3. I AGREE TO EXECUTE THE REQUIRED DOCUMENTS ABANDONING ANY EXISTING EASEMENTS PURSUANT TO THE PROVISIONS OF N.R.S. 278.010 TO 278.630, INCLUSIVE;
4. ALL PROPERTY TAXES ON THE LAND FOR THE FISCAL YEAR HAVE BEEN PAID;
5. ANY LENDER WITH AN IMPOUND ACCOUNT FOR THE PAYMENT OF TAXES HAS BEEN NOTIFIED OF THE ADJUSTMENT OF THE BOUNDARY LINE OR THE TRANSFER OF THE LAND.

RIDGES DEVELOPMENT INC., A NEVADA CORPORATION

*David J. Thompson*  
DAVID J. THOMPSON  
PRESIDENT

STATE OF NEVADA }  
COUNTY OF WASHOE } S.S.

THIS INSTRUMENT WAS ACKNOWLEDGED BEFORE ME ON THE 8<sup>th</sup> DAY OF August 2007 BY DAVID J. THOMPSON

*Jo A. Pinther*  
NOTARY PUBLIC

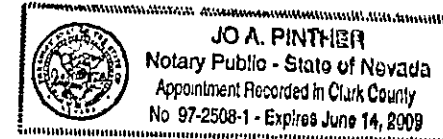

**OWNER'S CERTIFICATE**

I, THE UNDERSIGNED OWNER OF THE AFFECTED PARCELS AS SHOWN ON THIS MAP DOES HEREBY STATE:

1. I HAVE EXAMINED THIS PLAT AND APPROVE AND AUTHORIZE ITS RECORDING;
2. I AGREE TO EXECUTE THE REQUIRED DOCUMENTS CREATING ANY EASEMENT WHICH IS SHOWN HEREON;
3. I AGREE TO EXECUTE THE REQUIRED DOCUMENTS ABANDONING ANY EXISTING EASEMENTS PURSUANT TO THE PROVISIONS OF N.R.S. 278.010 TO 278.630, INCLUSIVE;
4. ALL PROPERTY TAXES ON THE LAND FOR THE FISCAL YEAR HAVE BEEN PAID;
5. ANY LENDER WITH AN IMPOUND ACCOUNT FOR THE PAYMENT OF TAXES HAS BEEN NOTIFIED OF THE ADJUSTMENT OF THE BOUNDARY LINE OR THE TRANSFER OF THE LAND.

DAVID J. THOMPSON AND CLAUDIA ANN THOMPSON FAMILY TRUST, DATED JUNE 1, 2004

*David J. Thompson*  
DAVID J. THOMPSON, TRUSTEE

*Claudia Ann Thompson*  
CLAUDIA ANN THOMPSON, TRUSTEE

STATE OF NEVADA }  
COUNTY OF WASHOE } S.S.

THIS INSTRUMENT WAS ACKNOWLEDGED BEFORE ME ON THE 10<sup>th</sup> DAY OF August 2007 BY DAVID J. THOMPSON AND CLAUDIA ANN THOMPSON.

*Jo A. Pinther*  
NOTARY PUBLIC

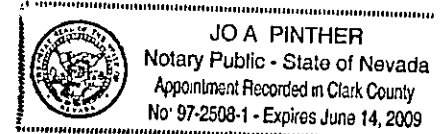

**PROJECT SITE**

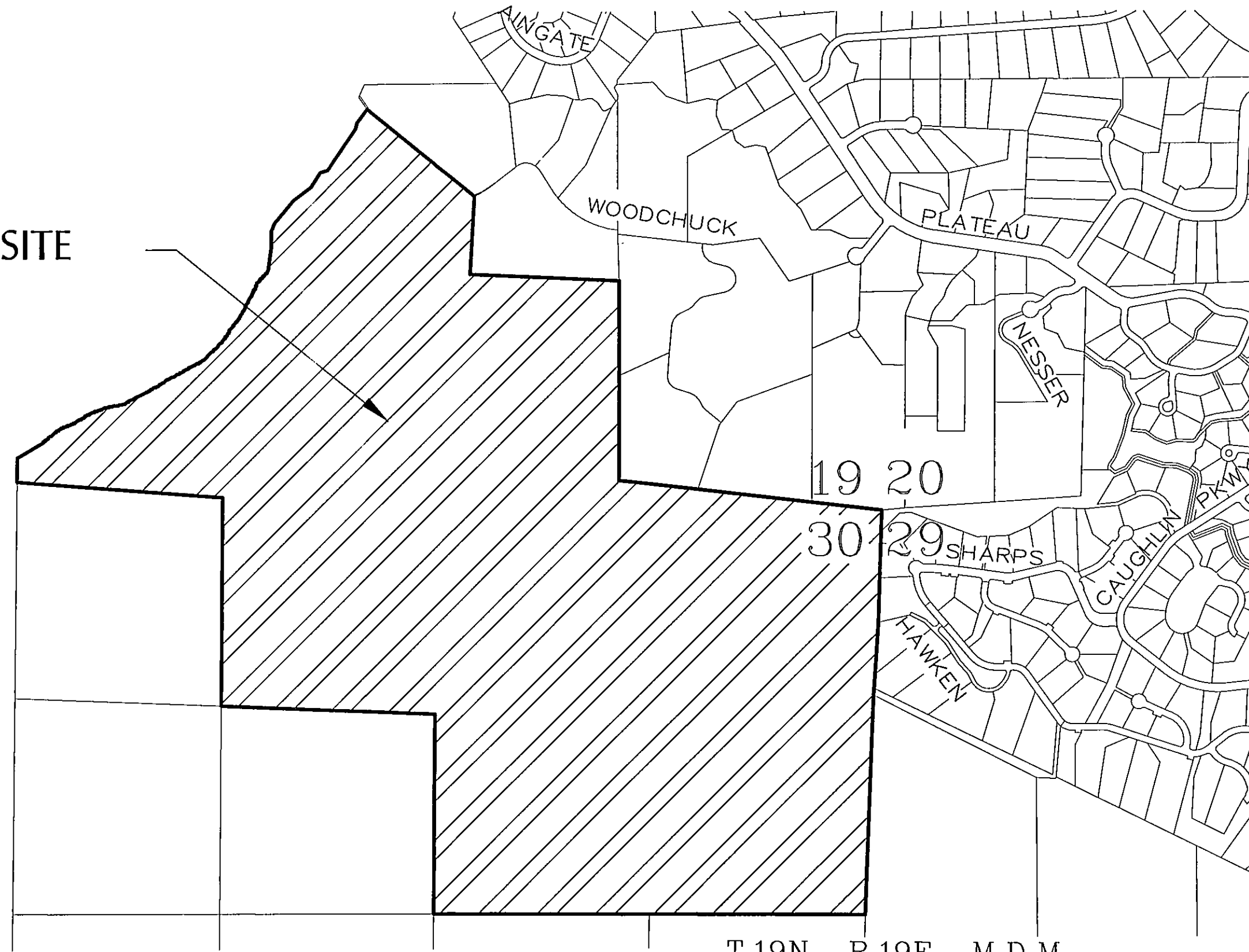

T.19N., R.19E., M.D.M.

**VICINITY MAP**  
N.T.S.

**OWNER'S CERTIFICATE**

I, THE UNDERSIGNED OWNER OF THE AFFECTED PARCELS AS SHOWN ON THIS MAP DOES HEREBY STATE:

1. I HAVE EXAMINED THIS PLAT AND APPROVE AND AUTHORIZE ITS RECORDING;
2. I AGREE TO EXECUTE THE REQUIRED DOCUMENTS CREATING ANY EASEMENT WHICH IS SHOWN HEREON;
3. I AGREE TO EXECUTE THE REQUIRED DOCUMENTS ABANDONING ANY EXISTING EASEMENTS PURSUANT TO THE PROVISIONS OF N.R.S. 278.010 TO 278.630, INCLUSIVE;
4. ALL PROPERTY TAXES ON THE LAND FOR THE FISCAL YEAR HAVE BEEN PAID;
5. ANY LENDER WITH AN IMPOUND ACCOUNT FOR THE PAYMENT OF TAXES HAS BEEN NOTIFIED OF THE ADJUSTMENT OF THE BOUNDARY LINE OR THE TRANSFER OF THE LAND.

DAVID AND DUSTY ANNE DURKEE FAMILY TRUST AGREEMENT DATED AUGUST 20, 2004.

*David E. Durkee*  
DAVID E. DURKEE, TRUSTEE

*Dustanne E. Durkee*  
DUSTANNE E. DURKEE, TRUSTEE

STATE OF NEVADA }  
COUNTY OF WASHOE } S.S.

THIS INSTRUMENT WAS ACKNOWLEDGED BEFORE ME ON THE 13<sup>th</sup> DAY OF August 2007 BY DAVID E. AND DUSTANNE E. DURKEE TRUSTEES OF THE DAVID AND DUSTY ANNE DURKEE FAMILY TRUST AGREEMENT.

*Jo A. Pinther*  
NOTARY PUBLIC

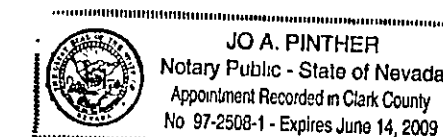

**SECURITY INTEREST HOLDERS CERTIFICATE**

THIS IS TO CERTIFY THAT THE LENDERS PER DEEDS OF TRUSTS

DOCUMENT NO.S: NOT REQUIRED

DATED: NOT REQUIRED

HAVE CONSENTED TO THE PREPARATION AND RECORDATION OF THIS PLAT BY SEPARATE

DOCUMENT NO.S 3568588 AND 3568589

**TAX CERTIFICATE**

THE UNDERSIGNED HEREBY CERTIFIES THAT ALL PROPERTY TAXES ON THE LAND SHOWN ON THIS PLAT HAVE BEEN PAID FOR THE FISCAL YEAR, AND THAT THE FULL AMOUNT OF ANY DEFERRED PROPERTY TAXES FOR THE CONVERSION OF THE PROPERTY FROM AGRICULTURAL USE HAS BEEN PAID PURSUANT TO NRS 361A.265.

*Danny P. Richard* 8/9/07  
WASHOE COUNTY TREASURER DATE

*Assistant Chief Deputy Treasurer*  
TITLE

**GOVERNING AGENCY CERTIFICATE**

WASHOE COUNTY HAS REVIEWED AND APPROVED THIS MAP.

*Jack Holmes* 9/14/07  
JACK HOLMES, PLS DATE  
WASHOE COUNTY SURVEYOR

JOB # 2405.0005

**COUNTY RECORDER'S CERTIFICATE**

FILE NO: 3576232

FILED FOR RECORD AT THE REQUEST OF Dean L. Merante

ON THIS 10 DAY OF Sept, 2007

AT 50 MINUTES PAST 11 O'CLOCK, P.M., OFFICIAL RECORDS OF WASHOE COUNTY, NEVADA.

*Kathryn L. Burke*  
COUNTY RECORDER

BY: *C. Bartley*  
DEPUTY

FEE: \$ 41.00

**RECORD OF SURVEY**

SHOWING A  
**BOUNDARY LINE ADJUSTMENT**  
RIDGES DEVELOPMENT INC  
PARCELS A THROUGH E OF SURVEY NO. 4540  
AND PARCEL 3 OF PM 1298  
SITUATE IN THE S1/2 OF SECTION 19 AND THE N1/2 OF SECTION 30  
TOWNSHIP 19 NORTH, RANGE 19 EAST, M.D.M.

WASHOE COUNTY NEVADA

**JEFF CODEGA**  
PLANNING/DESIGN, INC.  
planners landscape architects engineers  
750 South Loop Reno Nevada 89501 775 332 9600 or 775 332 5551

SHEET 1 of 3

JULY 2007

CURRULATIVE INDEXES SHOULD BE EXAMINED FOR ANY SUBSEQUENT CHANGES TO THIS MAP

CURRULATIVE INDEXES 4965 SHOULD BE EXAMINED FOR ANY SUBSEQUENT CHANGES TO THIS MAP

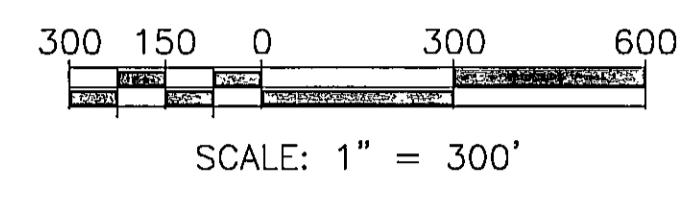
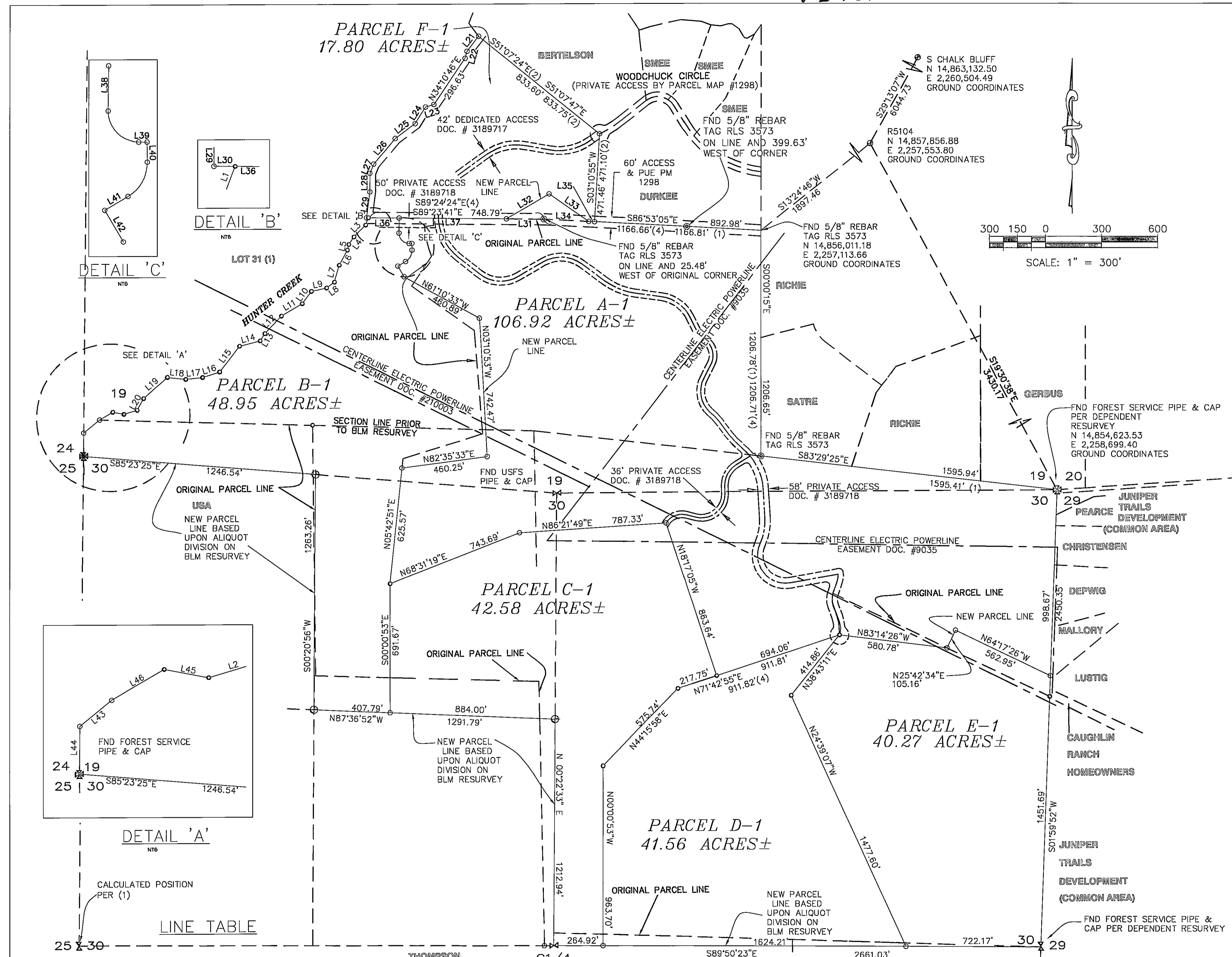

**LEGEND**

- SET 5/8" REBAR/CAP "PLS 3318"
- FOUND GPS POINTS
- FOUND MONUMENT PER (4) OR AS NOTED
- ⊕ FOUND MONUMENT PER (1) OR AS NOTED
- + DIMENSION PT. NOTHING FOUND, NOTHING SET
- (#) REFERENCE
- NEW PARCEL LINES
- - - ADJACENT PROPERTY LINES
- - - ACCESS RIGHT OF WAY
- ⊗ FOUND AL. FOREST SERVICE PIPE & CAP PER BLM RESURVEY APPROVED JULY 21, 2006 OR AS NOTED
- ⊗ 1/4 SECTION CORNER
- ⊗ 1/16 SECTION CORNER - FOUND FOREST SERVICE PIPE AND CAP

**REFERENCES**

1. LAND MAP #43, DOCUMENT #599440.
2. PARCEL MAP #1298, DOCUMENT #769502.
3. TRACT MAP #2688, DOCUMENT #1400211.
4. SURVEY MAP #4540, DOCUMENT #3189720.
5. UNRECORDED BLM DEPENDENT RESURVEY PLAT

**BASIS OF BEARING**

NEVADA STATE PLANE COORDINATE SYSTEM, WEST ZONE, NORTH AMERICAN DATUM, 1983/94 AS ESTABLISHED BY TIES TO GPS POINTS S CHALK BLUFF AND R5104. DIVIDE THESE GROUND COORDINATES BY 1.000197939 TO OBTAIN GRID.

TOTAL AREA 299.09 ACRES

**NOTES**

1. THIS RECORD OF SURVEY IS NOT IN CONFLICT WITH N.R.S. CHAPTER 278.010 TO 278.630, INCLUSIVE, AS THE PARCELS SHOWN ARE A RECONFIGURATION OF EXISTING PARCELS.
2. THIS RECORD OF SURVEY IS IN CONFORMANCE WITH N.R.S. CHAPTER 625.340.
3. THIS RECORD OF SURVEY SHOWS THE BOUNDARY LINE ADJUSTMENT RECORDED IN THE WASHOE COUNTY RECORDS MAP NO. S4540 AD DOCUMENT NO. 3189720.
4. THE AREAS SHOWN ON THIS MAP REFLECT THE BOUNDARY LINE ADJUSTMENT.
5. THE ORIGINAL PARCEL LINES ARE THE CENTERLINE OF THE 60' WIDE PUE AND ACCESS ROADWAY EASEMENTS PER LAND MAP 43.
6. ROADWAY AND PUBLIC UTILITY EASEMENTS PER LAND MAP 43 ON NEW PARCEL A TO BE RELINQUISHED PRIOR TO FINAL SUBDIVISION. ALL OTHER ROADWAY AND PUBLIC UTILITY EASEMENTS TO REMAIN.
7. TITLE REPORT PROVIDED BY TICOR TITLE OF NEVADA, INC. ORDER NO. 06001834-TO DATED DECEMBER 7, 2006 AT 7:30 AM.

**LINE TABLE**

| LINE | LENGTH | BEARING     | LINE | LENGTH | BEARING     |
|------|--------|-------------|------|--------|-------------|
| L1   | 41.48  | S20°40'59"W | L24  | 105.10 | N31°59'56"E |
| L2   | 74.07  | S73°23'43"W | L25  | 132.53 | N53°15'10"E |
| L3   | 88.64  | S44°38'30"W | L26  | 178.34 | N40°09'37"E |
| L4   | 49.00  | S34°32'02"W | L27  | 53.09  | N22°31'23"E |
| L5   | 31.21  | S14°03'20"W | L28  | 100.57 | N00°03'46"E |
| L6   | 92.58  | S28°13'08"W | L29  | 139.08 | N07°18'28"E |
| L7   | 93.18  | S19°58'28"W | L30  | 9.42   | N89°23'41"W |
| L8   | 52.34  | S53°30'40"W | L31  | 199.83 | N89°23'41"W |
| L9   | 83.52  | S77°47'23"W | L32  | 263.59 | N59°57'17"E |
| L10  | 82.08  | S36°13'34"W | L33  | 259.17 | S55°22'43"E |
| L11  | 129.55 | S59°34'18"W | L34  | 242.19 | N86°53'05"W |
| L12  | 128.72 | S43°24'00"W | L35  | 31.40  | N86°53'05"W |
| L13  | 45.88  | S33°32'14"W | L36  | 164.71 | N89°23'41"W |
| L14  | 114.20 | S75°17'52"W | L37  | 574.66 | N89°23'41"W |
| L15  | 174.08 | S37°37'48"W | L38  | 80.32  | N00°35'24"E |
| L16  | 95.92  | S72°51'56"W | L39  | 14.94  | S89°24'36"E |
| L17  | 90.49  | S84°03'04"W | L40  | 35.92  | S00°43'48"E |
| L18  | 99.12  | N83°59'45"W | L41  | 48.27  | S59°26'14"W |
| L19  | 169.96 | S48°32'31"W | L42  | 65.52  | N30°33'46"W |
| L20  | 71.21  | S28°32'26"W | L43  | 110.12 | S50°41'47"W |
| L21  | 100.77 | S37°46'12"W | L44  | 126.34 | N00°30'36"E |
| L22  | 39.40  | N15°15'59"E | L45  | 60.71  | S79°13'47"E |
| L23  | 46.96  | N73°07'15"E | L46  | 81.18  | N59°28'35"E |

**CURVE TABLE**

| CURVE | LENGTH | RADIUS | DELTA     |
|-------|--------|--------|-----------|
| C1    | 86.39  | 55.00  | 90°00'00" |
| C2    | 73.51  | 70.00  | 60°10'02" |

CUMULATIVE INDEXES SHOULD BE EXAMINED FOR ANY SUBSEQUENT CHANGES TO THIS MAP

3576232

JOB # 2405.0005 **3576232**

**RECORD OF SURVEY**  
SHOWING A  
**BOUNDARY LINE ADJUSTMENT**  
RIDGES DEVELOPMENT INC  
PARCELS A THROUGH E OF SURVEY NO. 4540  
AND PARCEL 3 OF PM 1298  
SITUATE IN THE S1/2 OF SECTION 19 AND THE N1/2 OF SECTION 30  
TOWNSHIP 19 NORTH, RANGE 19 EAST, M.D.M.

WASHOE COUNTY NEVADA

**JEFF CODEGA**  
PLANNING/DESIGN, INC.  
planners • landscape architects • engineers  
720 South Blvd • Reno, Nevada 89501 • (775) 323-6222 • (775) 323-1111



SHEET 2 of 3  
AUGUST 2007

CUMULATIVE INDEXES SHOULD BE EXAMINED FOR ANY SUBSEQUENT CHANGES TO THIS MAP

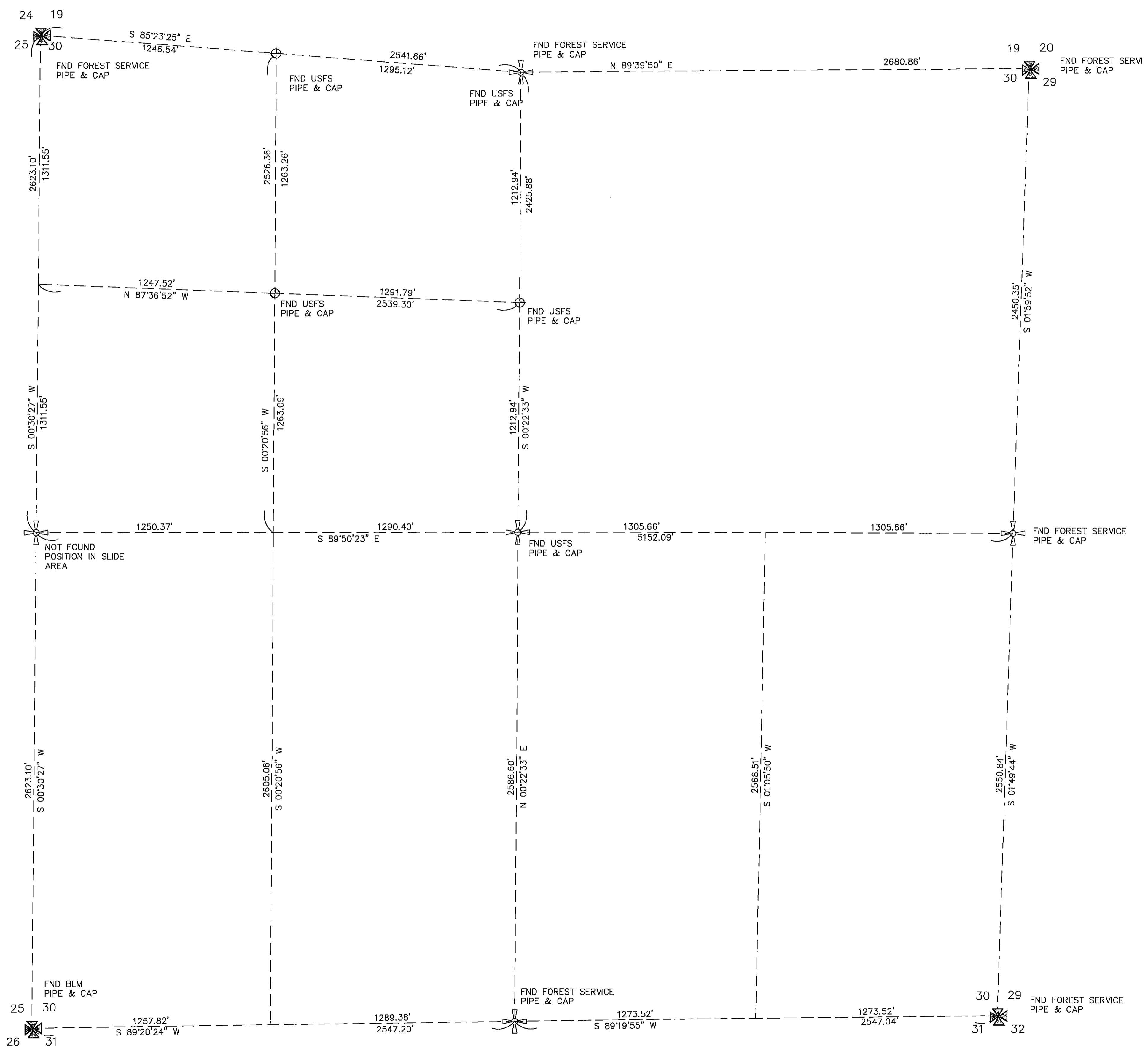
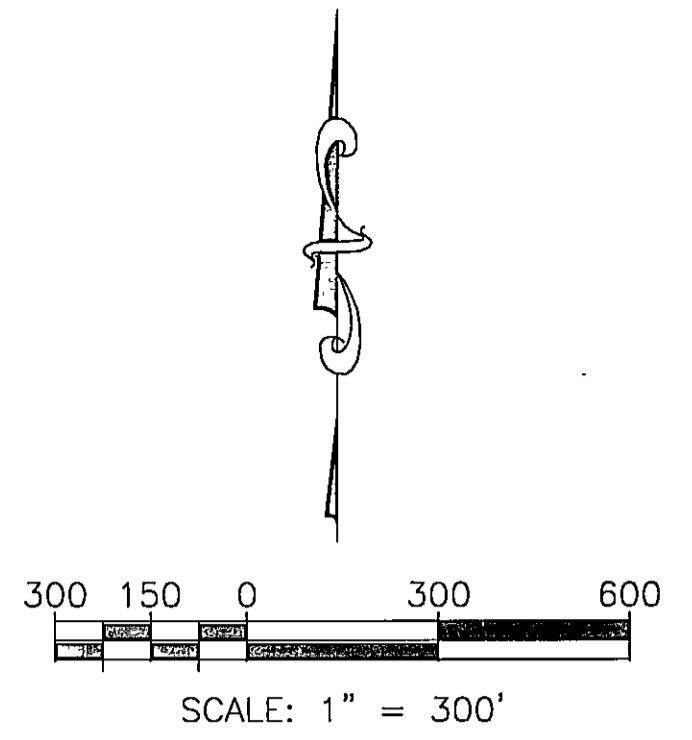
4965B

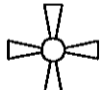

NOTE:  
SECTION BREAKDOWN SHOWN  
BASED ON DEPENDENT RESURVEY  
DONE BY BLM 2006

-  1/4 SECTION CORNER
-  1/16 SECTION CORNER FOUND  
ALL OTHERS NOT FOUND
-  SECTION CORNER

CUMULATIVE INDEXES  
 SHOULD BE EXAMINED  
 FOR ANY SUBSEQUENT  
 CHANGES TO THIS MAP

3516232

JOB # 2405.0005 3516232

**RECORD OF SURVEY**  
 SHOWING A  
**BOUNDARY LINE ADJUSTMENT**  
 RIDGES DEVELOPMENT INC  
 PARCELS A THROUGH E OF SURVEY NO. 4540  
 AND PARCEL 3 OF PM 1298  
 SITUATE IN THE S1/2 OF SECTION 19 AND THE N1/2 OF SECTION 30  
 TOWNSHIP 19 NORTH, RANGE 19 EAST, M.D.M.

WASHOE COUNTY NEVADA

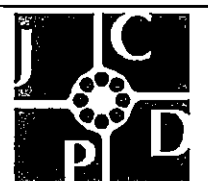
|                                                                                                                                                                                                                                                                                         |                            |
|-----------------------------------------------------------------------------------------------------------------------------------------------------------------------------------------------------------------------------------------------------------------------------------------|----------------------------|
|  <b>JEFF CODEGA</b><br>PLANNING/DESIGN, INC.<br><small>planners • landscape architects • engineers</small><br><small>702 South Blvd • Reno, Nevada 89501 • (775) 323-6274 • (775) 323-1127</small> | SHEET <u>3</u> of <u>3</u> |
|                                                                                                                                                                                                                                                                                         | AUGUST 2007                |

Record of Survey Map 4965B

CUMULATIVE INDEXES  
 SHOULD BE EXAMINED  
 FOR ANY SUBSEQUENT  
 CHANGES TO THIS MAP

WMPA23-0006 AND  
WRZA23-0009  
EXHIBIT F

Thompson Family Trust Discovery - 8 SFR  
Preliminary Demand Calculations  
22-8371

| Line<br>No. | Lot<br>Number | Lot Size<br>(sq. ft.) | Max. Day Demand<br>Calculation (gpm) |
|-------------|---------------|-----------------------|--------------------------------------|
| 1           | 1             | 37,462                | 1.3                                  |
| 2           | 2             | 40,946                | 1.3                                  |
| 3           | 3             | 37,897                | 1.3                                  |
| 4           | 4             | 33,541                | 1.2                                  |
| 5           | 5             | 26,136                | 1.1                                  |
| 6           | 6             | 32,670                | 1.2                                  |
| 7           | 7             | 40,075                | 1.3                                  |
| 8           | 8             | 43,560                | 1.4                                  |
|             |               | <hr/> 292,287         | <hr/> 10.1                           |

Demand Equation:  $y = 0.0066x^{0.5}$

where:    y = maximum day demand in gpm  
              x = lot size in square feet

Estimated historical residential peaking factors:

MDD:ADD = 2.13:1

PKHR:MDD = 1.8:1

Demand Summary:

ADD =       4.7 gpm  
MDD =       10.1 gpm  
PKHR =      18.2 gpm

Landscape demand: unknown

ADD =       0.0 gpm  
MDD =       0.0 gpm  
PKHR =      0.0 gpm



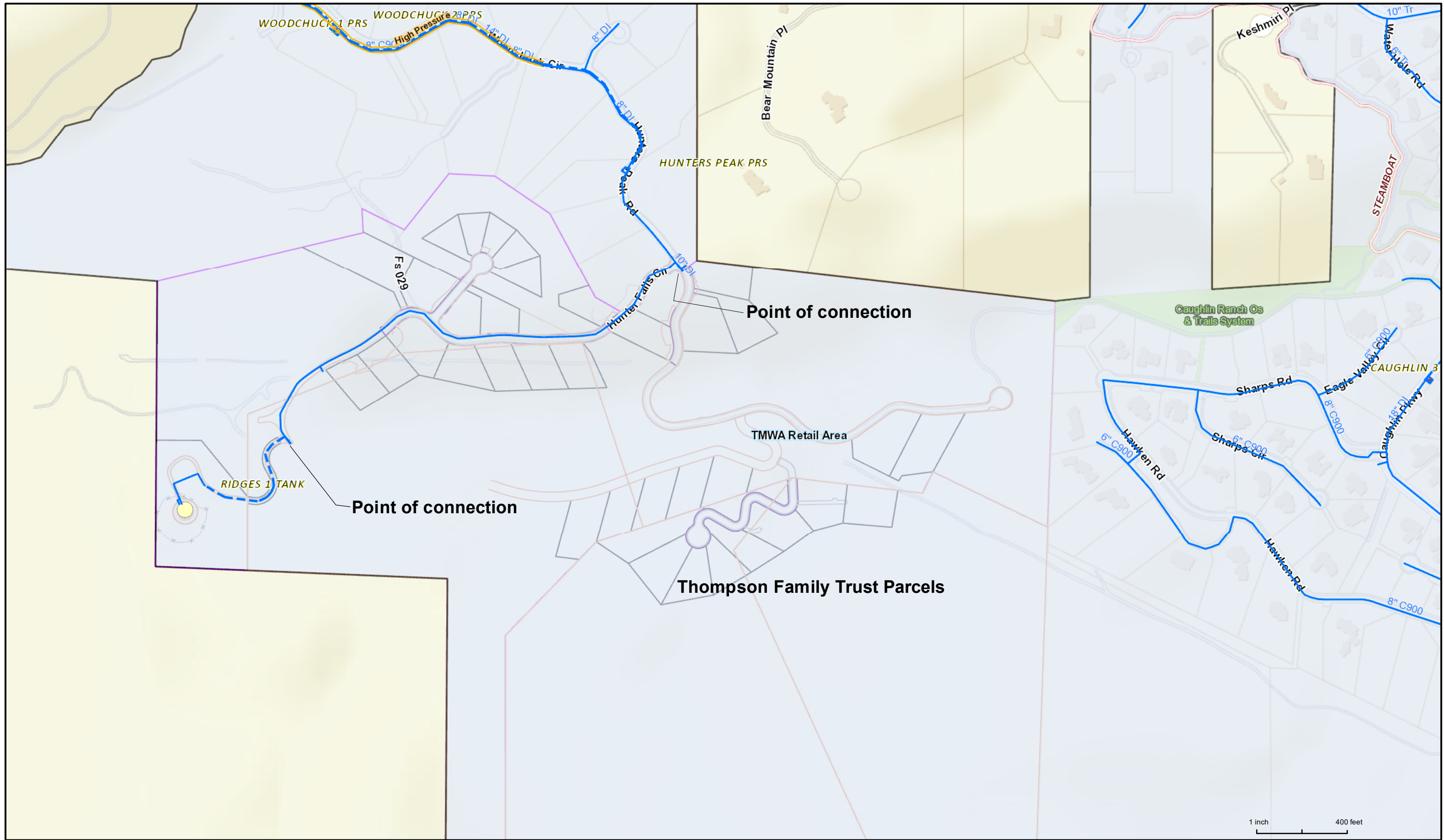

1 inch = 400 feet



Existing TMWA Facilities  
22-8371 Thompson Family Trust Discovery

|         |                   |
|---------|-------------------|
| DATE:   | 1/28/2022         |
| MAP BY: | H Flores          |
| REQ BY: |                   |
| SCALE:  | 1 inch = 400 feet |



**WMPA23-0008 AND  
WRZA23-0009  
EXHIBIT F**

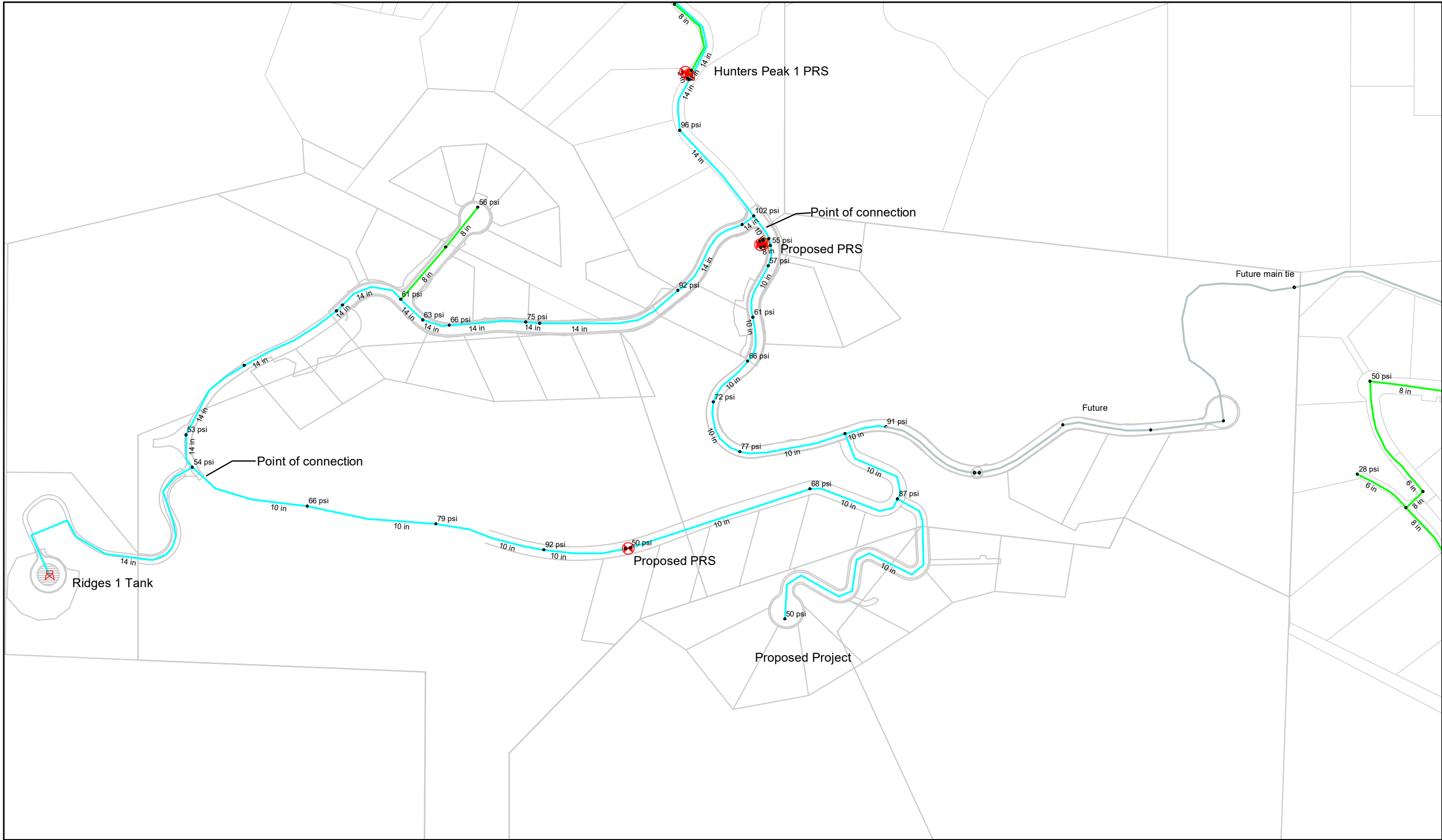

d:\c:\path\stamp\to\to copy and paste\d\c\path\here



Thompson Family Trust Discovery  
 Preliminary Water Facility Plan  
 Hunter Creek System

|             |                   |
|-------------|-------------------|
| DATE:       | 1/28/2022         |
| MAP BY:     | hmf               |
| WORK ORDER: | 22-8371           |
| SCALE:      | 1 inch = 278 feet |



**WMPA23-0008 AND  
 WRZA23-0009  
 EXHIBIT F**

Date: January 19, 2022

To: Nancy Raymond

From: Eden Catudan

RE: 22-8371 Thompson Family Trust Discovery, +/- 8 SFR Custom lots, APNs 041-650-04 & 05

The New Business/Water Resource team will answer the following assumptions on each new discovery:

- Is the property within Truckee Meadows Water Authority's water service territory?
- Does the property have Truckee River water rights appurtenant to the property, groundwater or resource credits associated with the property?
  - If yes, what is the status of the water right: Agricultural or Municipal and Domestic use?
- Estimated water demand for residential and or commercial projects.
- Any special conditions, or issues, that are a concern to TMWA or the customer.

The following information is provided to complete the Discovery as requested:

- These subject parcels (APNs 041-650-04 & 05) are within Truckee Meadows Water Authority's (TMWA's) service territory. An annexation is not required.
- There are no resource credits or, according to the State of Nevada Division of Water Resources (NDWR), no Truckee River decreed water rights appurtenant to this property. The developer will be required to follow TMWA's current rules, specifically Rule 7, and pay all fees for water rights needed in order to obtain a will serve commitment letter.
- Based on the information provided by the applicant this project "Thompson Family Trust Discovery" is estimated to require a domestic demand of **5.28 acre-feet (AF)**. No landscaping plans were provided, therefore, no demand calculation provided. Please see the attached demand calculation sheet for the **estimated** domestic demand and water resource fees. Once final plans are submitted a more accurate demand will be calculated. *Note: Water rights held or banked by the applicant, if acceptable, must be dedicated to a project before any rule 7 water resources are purchased from TMWA. will be based on the duty of the surface water permit used for dedication for this project.*
- Any existing right of ways and public easements would need to be reviewed, and if needed the property owner will need to grant TMWA the proper easements and/or land dedications to provide water service to the subject properties. Property owner will be required, at its sole expense, to provide TMWA with a current preliminary title report for all subject properties. Owner will represent and warrant such property offered for dedication or easements to TMWA shall be free and clear of all liens and encumbrances. Owner is solely responsible for obtaining all appropriate permits, licenses, construction easements, subordination agreements, consents from lenders, and other necessary rights from all necessary parties to dedicate property or easements with title acceptable to TMWA.

**THOMPSON FAMILY TRUST SUBDIVISION DISCOVERY**  
**SURFACE WATER RIGHTS AND WATER RESOURCE SUSTAINABILITY FEE**  
**CALCULATION WORKSHEET**

| Line No. | Lot Number                                    | Lot Size    | Demand Calculation |
|----------|-----------------------------------------------|-------------|--------------------|
| 1        | 1                                             | <u>0.86</u> | <u>0.67</u>        |
| 2        | 2                                             | <u>0.94</u> | <u>0.68</u>        |
| 3        | 3                                             | <u>0.87</u> | <u>0.67</u>        |
| 4        | 4                                             | <u>0.77</u> | <u>0.65</u>        |
| 5        | 5                                             | <u>0.60</u> | <u>0.60</u>        |
| 6        | 6                                             | <u>0.75</u> | <u>0.64</u>        |
| 7        | 7                                             | <u>0.92</u> | <u>0.68</u>        |
| 8        | 8                                             | <u>1.00</u> | <u>0.69</u>        |
|          |                                               | 6.71        | <u>5.28</u>        |
|          | Less: Demand Credits                          |             | <u>0.00</u>        |
|          | NET PROJECT DEMAND                            |             | 5.28               |
|          | Water Rights (0.11 AF per AF of total demand) |             | <u>0.58</u>        |
|          | TOTAL WATER RIGHTS REQUIRED                   |             | <u>5.86</u>        |

|                                                          |         |    |               |
|----------------------------------------------------------|---------|----|---------------|
| Price of Water Rights per AF                             | \$7,700 | \$ | 45,122        |
| Water Resource Sustainability (AF of Net Project Demand) | \$1,600 | \$ | 8,448         |
| Will Serve Letter Preparation                            |         | \$ | 150           |
| <b>TOTAL TO TRUCKEE MEADOWS WATER AUTHORITY</b>          |         | \$ | <u>53,720</u> |
|                                                          |         |    | =====         |

SUBMITTED BY: David & Claudia Thompson PHONE: Colin Hayes 787-4379

APN: 041-650-04 & 05 DATE: 1/19/2022

PROJ NO: 22-8371 CALCED BY: Eden 834-8053

REMARKS: **This quote is for water rights fees associated with the demand**  
**and does not include other TMWA fees such as the Area Facility Charge**  
**and other WSF fees. Fee quotes are valid only within 10 days of**  
**quote date.**

# Application Update - November 22, 2023, Additional Materials



October 30, 2023

**Kat Oakley, Planner**  
**Planning & Building Division**  
**Community Services Department**  
1001 East Ninth Street  
Reno, NV 89512

**Re: Thompson Family Trust (WMPA23-0008/WRZA23-0009)**

Dear Kat:

Following are responses that address staff comments in your two emails dated 10/5/23 and 10/20/23.

- 1) Please see the attached exhibits including:
  - a) A Revised Slope Map
  - b) A revised Grading Plan
  - c) A revised Site & Utility Plan
  - d) Composite slope map with Ridges & Thompson site

I realize this is highly unusual to have this level of engineering detail for a zone change request of project review. However, we want to provide a bullet-proof commitment and analysis to staff comments and assign homes and disturbance to the flatter portions of the site. That means slope analysis aligning with the site plan with assigned building footprints that also aligns with the grading plan.

- 2) See attached revised slope map. We have eliminated one lot by combining lots 3-5 to make them 2 lots. The lot lines have been pulled back from the sloped area to reduce encroachment into that 30% slope area. Note that while the lot lines extend into the 30% slope area that area will remain native per attached exhibit. The revised LDS zoning boundary includes 8.36 acres or 10.3% of the 81.5-acre site. We are willing to discuss option to restrict the almost 90% majority of the site to perpetual open space by O.S zoning or what ever mechanism is preferred by staff.
- 3) Per the slope map, the revised calculations show a total of 2.1+/- acres of 30% slope in the development area/rezoning area. That is only  $\frac{1}{4}$  ( $2.1 / 8.36=0.25$ ) of the total development footprint and only 4% ( $2.1 / 52.6$ ) of the total 30% on the entire site. Of the 2.1 acres, we are showing 1.9 acres of that area to be deed restricted. That means only about 0.2 acres of 30% or more area within the zoning boundary would be disturbed by road grading or house grading. The disturbed 0.2 acres (30% o+ slope) within the new zoning boundary is about 2.4% of the zoning boundary area ( $0.2/8.36$ )
- 4) See the attached composite map with the Ridges project and Thompson 7-lot plan that shows lots overlaid to the slope map. There are 15 lots that include 30% slope in the approved Ridges plan. It is common and frankly a given that small areas of 30% slope will be found on some lots (for most projects) that involve hillside development. That proposed for this project is consistent with prior practice in WC and related project approvals. A key point is that lots lines and parcel boundaries may include the 30% slope with restrictions from grading and building in those areas as part of the process.

**WMPA23-0008 AND**  
**WRZA23-0009**  
**EXHIBIT F**

- 5) We identify building envelopes for every lot on the map. These include a minimum of roughly 3,000 sf area that is specific for future home pads. This tool is to pinpoint the lot development on the flatter areas on each lot.
- 6) A no-build zone has been established on the map and declared as such in this zoning process and related maps.
- 7) We will deed and/or map restrict the no-build zone on the 30% sloped part of the lots. While this is a disclosure at this point in the process, it will be on record when a Tentative Map comes forward.
- 8) The plan is compliant with all the land use regulations you have referenced in the email copied below. There are no statements in any policy or code that prohibit what is being proposed.
- 9) See the attached TMRPA Map that shows the DCA and the proposed project area related to that map. I will prepare another map that shows the LDS zoning portion of the project inserted into the DCA map if you find this to be useful.

*Copied in from your email on October 20,2023 in italics with responses in blue:*

*Both our Land Use element and the Regional Plan also recognize slopes in excess of 30% as part of the Development Constraints Area (DCA), which, per the Regional Plan, "...should not be encroached upon for development" (pg 106). It goes on to state (as is mirrored in our master plan) that the DCA overlay takes precedence over otherwise applicable policies, and those limitations include a maximum density of one unit per 40 acres or one unit per parcel in existence at the time of plan adoption (pg 107). I've copied the relevant policy from the Regional Plan below:*

*The set of plans are extremely delicate and sensitive to the 30% slope areas as shown in the revised plans and analysis of the DCA area. The amount of encroachment is minimal and may be considered negligible with the restrictions we are willing to impose at a zoning level.*

### **Rural and Rural Residential Master Plan Categories**

#### **Intent**

The Rural and Rural Residential categories recognize the important contributions that ranching and other rural activities make to Washoe County. These categories are intended to preserve areas where agriculture, grazing and/or open space, and large lot residential predominate; and to discourage suburban sprawl into areas that lack essential infrastructure and services for intensification, or that have resource constraints such as steep slopes. In limited cases, and in conformance with the Truckee Meadows Regional Plan, rural resorts may be appropriate.

*The now 10% use of the site does nothing to compromise the intent or integrity of these land use categories. Specifically, this is not Suburban sprawl when it is physically attached to approved Suburban development with planned services to the site.*

#### **110.106.15 (f) Low Density Suburban Regulatory Zone.**

*The Low-Density Suburban (LDS) Regulatory Zone is intended to create and preserve areas where single-family, detached homes on one (1) acre lots are predominant. Small neighborhood commercial uses may be permitted when they serve the needs of residents and are compatible with the residential character of the area. The maximum number of dwelling units that may be located in this regulatory zone is one (1) unit per one (1) acre. The minimum lot area in this regulatory zone is thirty-five thousand (35,000) square feet.*

*The proposed plan meets all of the noted development code criteria with SF detached lots of 35,000 sf minimum and density of approximately 1 dwelling per acre.*

We look forward to constructively working thru any and all issues that concern you and other staff in prep for the December 6, 2023 Planning Commission hearing.

Sincerely,

A handwritten signature in black ink, appearing to read "John F. Krmpotic". The signature is stylized with a large initial "J" and "K".

John F. Krmpotic, AICP  
Principal



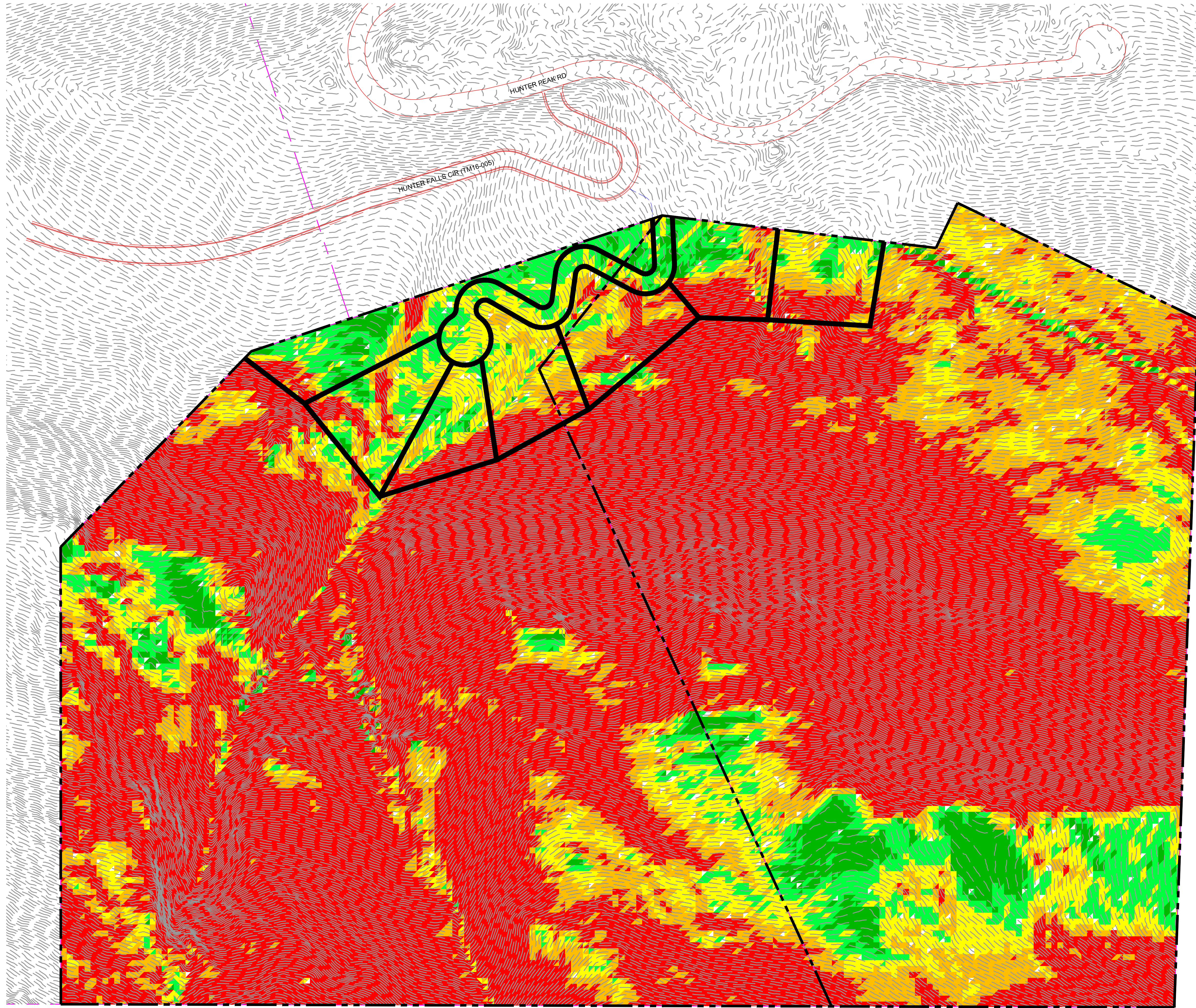

NOTE: EXISTING CONTOURS SHOWN WERE ACQUIRED FROM USGS AND DO NOT REPRESENT A SUMMIT ENGINEERING TOPOGRAPHICAL SURVEY.

| Slopes Table |             |             |               |
|--------------|-------------|-------------|---------------|
| Slope (%)    | Color       | Area (ac)   | % of Total    |
| 0 - 15       | Green       | 2.5         | 3.1%          |
| 15.1 - 20    | Light Green | 5.7         | 7.0%          |
| 20.1 - 25    | Yellow      | 9.1         | 11.2%         |
| 25.1 - 30    | Orange      | 11.6        | 14.2%         |
| 30+          | Red         | 52.6        | 64.5%         |
| <b>TOTAL</b> |             | <b>81.5</b> | <b>100.0%</b> |

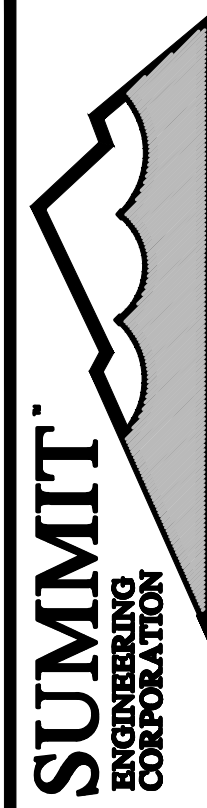
|                                                                                                                                   |                                                                                 |                                                                                         |        |               |                                        |
|-----------------------------------------------------------------------------------------------------------------------------------|---------------------------------------------------------------------------------|-----------------------------------------------------------------------------------------|--------|---------------|----------------------------------------|
| <br><b>SUMMIT</b><br>ENGINEERING<br>CORPORATION | 5405 MAE ANNE AVE. RENO, NV. 89523<br>PHONE: (775) 747-8550 FAX: (775) 747-8559 | DESIGNED BY:<br>DRAWN BY: cmenefee<br>CHECKED BY:<br>Copyright SUMMIT ENG 2023          | NEVADA | WASHOE COUNTY | BY APPD<br>DATE<br>DESCRIPTION<br>REV. |
| <b>DAVID THOMPSON</b><br><b>APN 041-650-04 &amp; 041-650-05</b><br><b>SLOPE MAP</b>                                               |                                                                                 |                                                                                         |        |               |                                        |
| SHEET<br><b>1</b><br>of<br><b>1</b>                                                                                               | SCALE<br>HORIZ: 1"=100'<br>VERT:<br>JOB NO:                                     | N:\DWG\SUB\143 Thompson\Woodchuck\Civil\Thompson - SlopeMap.DWG - 10:56 AM '23-OCT-2023 |        |               |                                        |

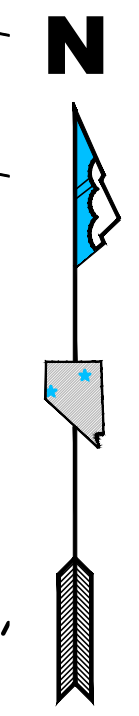
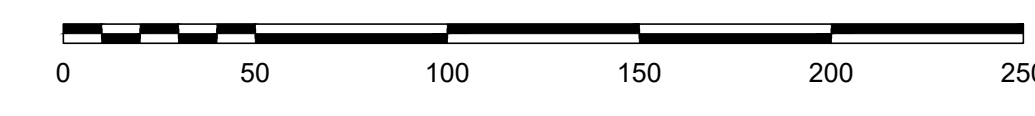
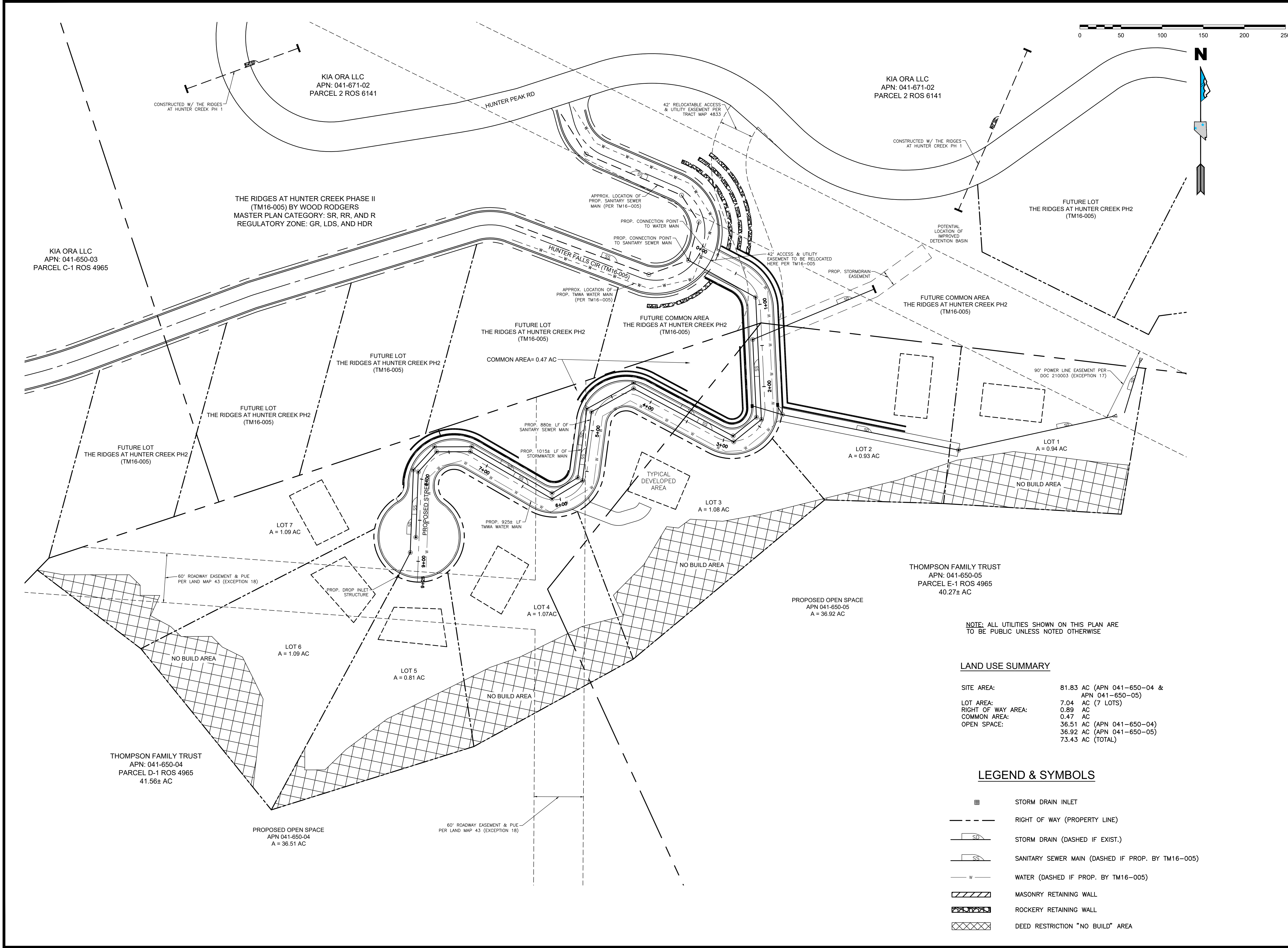

NOTE: ALL UTILITIES SHOWN ON THIS PLAN ARE TO BE PUBLIC UNLESS NOTED OTHERWISE

**LAND USE SUMMARY**

|                    |                                                                          |
|--------------------|--------------------------------------------------------------------------|
| SITE AREA:         | 81.83 AC (APN 041-650-04 & APN 041-650-05)                               |
| LOT AREA:          | 7.04 AC (7 LOTS)                                                         |
| RIGHT OF WAY AREA: | 0.89 AC                                                                  |
| COMMON AREA:       | 0.47 AC                                                                  |
| OPEN SPACE:        | 36.51 AC (APN 041-650-04) & 36.92 AC (APN 041-650-05) = 73.43 AC (TOTAL) |

**LEGEND & SYMBOLS**

- STORM DRAIN INLET
- RIGHT OF WAY (PROPERTY LINE)
- STORM DRAIN (DASHED IF EXIST.)
- SANITARY SEWER MAIN (DASHED IF PROP. BY TM16-005)
- WATER (DASHED IF PROP. BY TM16-005)
- MASONRY RETAINING WALL
- ROCKERY RETAINING WALL
- DEED RESTRICTION "NO BUILD" AREA

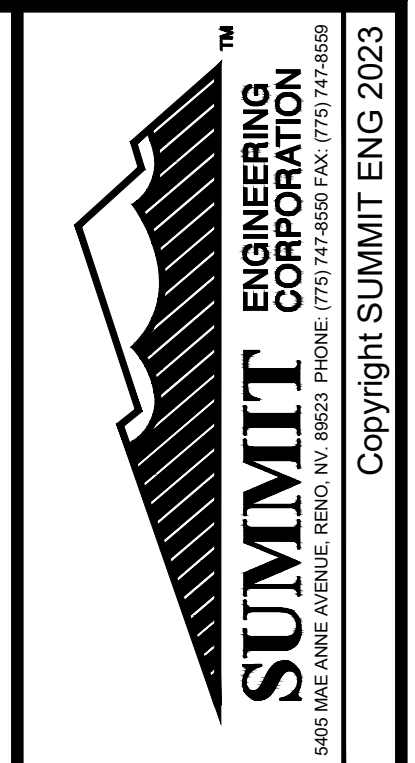

| REV. | DATE | DESCRIPTION | BY | APPD |
|------|------|-------------|----|------|
|      |      |             |    |      |

**THOMPSON FAMILY TRUST**  
**APN 041-650-04 & 041-650-05**  
**FIGURE #2 - CONCEPTUAL SITE AND UTILITY PLAN**  
 RENO WASHOE COUNTY NEVADA

|              |                           |
|--------------|---------------------------|
| JOB NO:      | 31143                     |
| DRAWN BY:    | cmenefee                  |
| DESIGNED BY: | CM                        |
| CHECKED BY:  | CH                        |
| SCALE:       | HORZ: 1"=50'<br>VERT: N/A |

|       |       |
|-------|-------|
| SHEET | TOTAL |
| 1     | 2     |

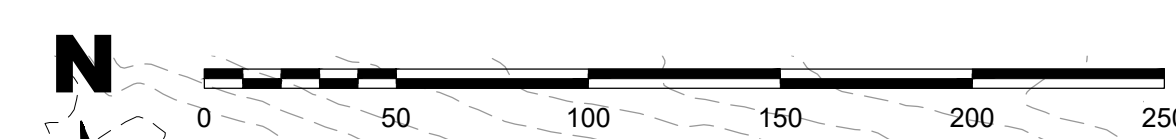
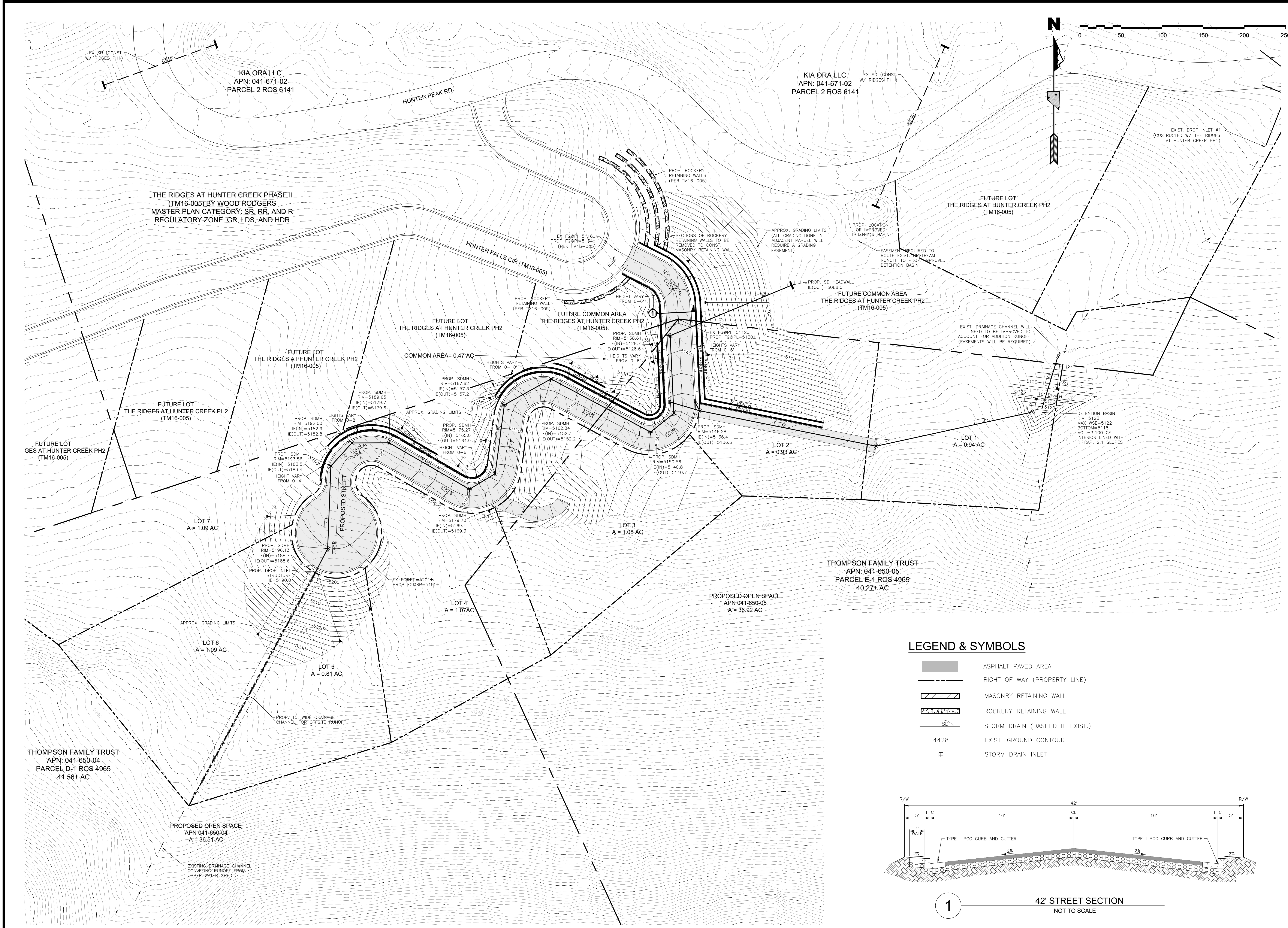

Copyright SUMMIT ENG 2023

| REV. | DATE | DESCRIPTION | BY | APPD |
|------|------|-------------|----|------|
|      |      |             |    |      |

**THOMPSON FAMILY TRUST**  
**APN 041-650-04 & 041-650-05**  
**FIGURE #3 - CONCEPTUAL GRADING PLAN**

|              |              |
|--------------|--------------|
| JOB NO:      | 31143        |
| DRAWN BY:    | cmenefee     |
| DESIGNED BY: | CM           |
| CHECKED BY:  | CH           |
| SCALE        | HORZ: 1"=50' |
|              | VERT: N/A    |

|       |   |       |   |
|-------|---|-------|---|
| SHEET | 2 | TOTAL | 2 |
|-------|---|-------|---|

**LEGEND & SYMBOLS**

- ASPHALT PAVED AREA
- RIGHT OF WAY (PROPERTY LINE)
- MASONRY RETAINING WALL
- ROCKERY RETAINING WALL
- STORM DRAIN (DASHED IF EXIST.)
- EXIST. GROUND CONTOUR
- STORM DRAIN INLET

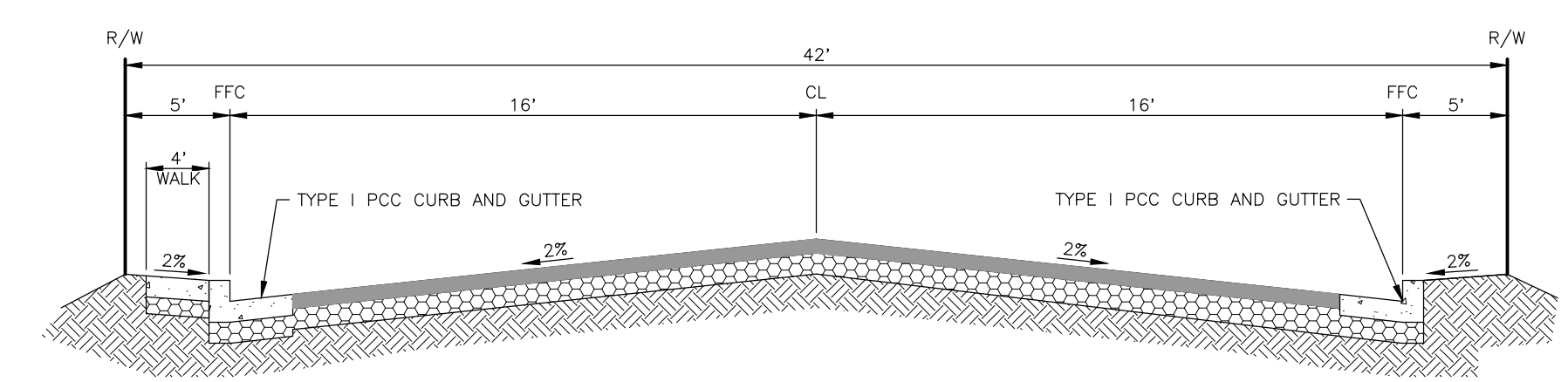

**1** 42' STREET SECTION  
NOT TO SCALE

RENO WASHOE COUNTY NEVADA  
 W:\DWG\31143\_ThompsonWoodchuck\Civil\ThompsonBaseMap\_CH.DWG - 10:43 AM - 28-OCT-2023

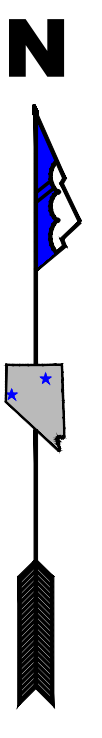
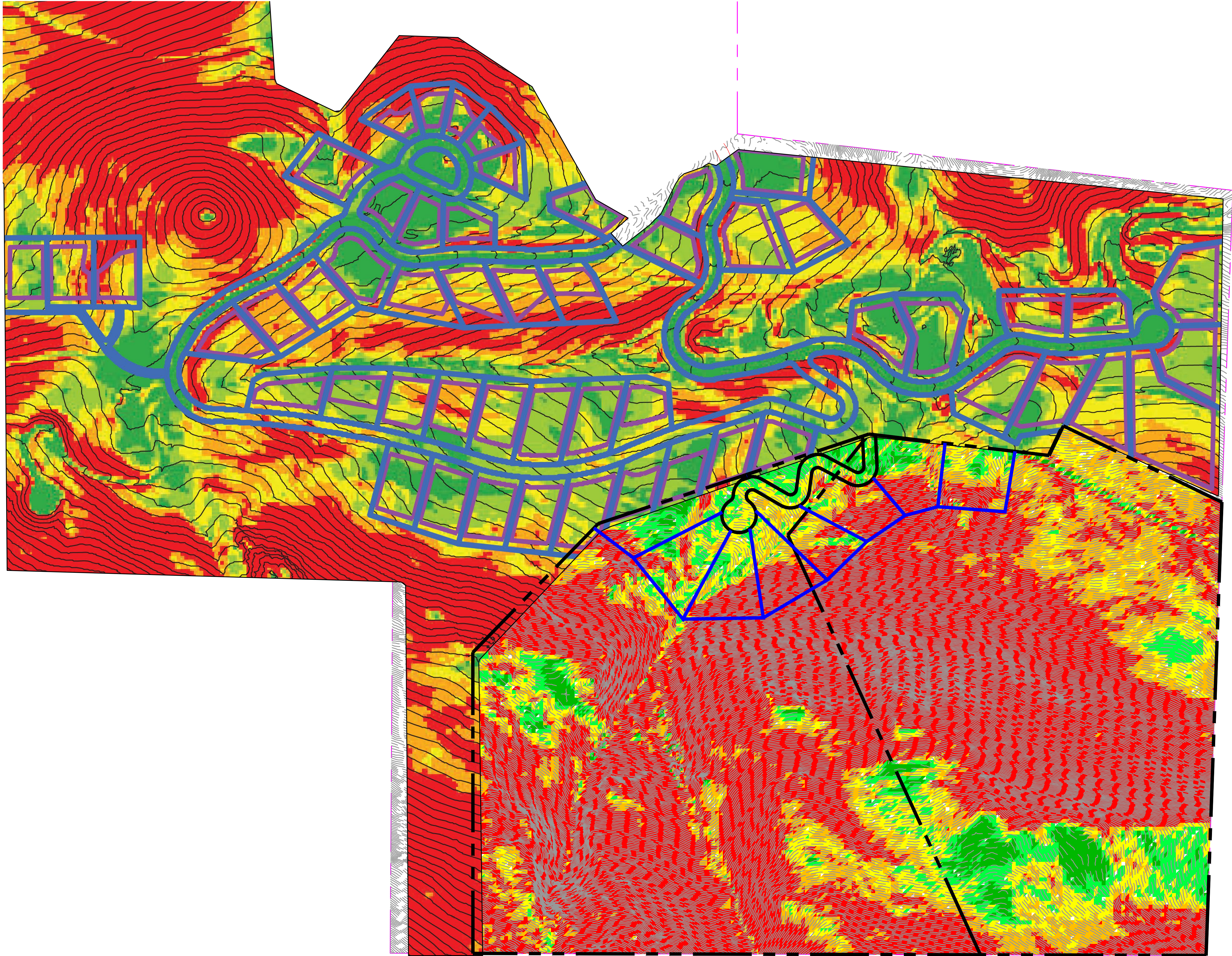

NOTE: EXISTING CONTOURS SHOWN WERE ACQUIRED FROM USGS AND DO NOT REPRESENT A SUMMIT ENGINEERING TOPOGRAPHICAL SURVEY.

| Slopes Table |       |             |               |
|--------------|-------|-------------|---------------|
| Slope (%)    | Color | Area (ac)   | % of Total    |
| 0 - 15       |       | 2.5         | 3.1%          |
| 15.1 - 20    |       | 5.7         | 7.0%          |
| 20.1 - 25    |       | 9.1         | 11.2%         |
| 25.1 - 30    |       | 11.6        | 14.2%         |
| 30+          |       | 52.6        | 64.5%         |
| <b>TOTAL</b> |       | <b>81.5</b> | <b>100.0%</b> |

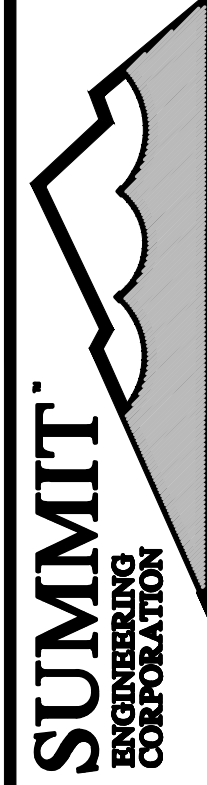

**SUMMIT**  
ENGINEERING  
CORPORATION

5405 MAE ANNE AVE. RENO, NV. 89523  
PHONE: (775) 747-8550 FAX: (775) 747-8559

DESIGNED BY: cmenefee

DRAWN BY: cmenefee

CHECKED BY: Copyright SUMMIT ENG 2023

---

**DAVID THOMPSON**

**APN 041-650-04 & 041-650-05**

**SLOPE MAP**

NEVADA

WASHOE COUNTY

---

| SHEET | SCALE          | REV. | DATE | DESCRIPTION | BY | APPD |
|-------|----------------|------|------|-------------|----|------|
| 1     | HORIZ: 1"=150' |      |      |             |    |      |
| 1     | VERT:          |      |      |             |    |      |
| 1     | JOB NO:        |      |      |             |    |      |

N:\DWS\J31143 Thompson\Woodchuck\Civil\Thompson\_SlopeMap\_Composite.DWG - 10:04 AM '25-01-28

Truckee Meadows Regional Plan (DCA Map of slopes greater than 30%)



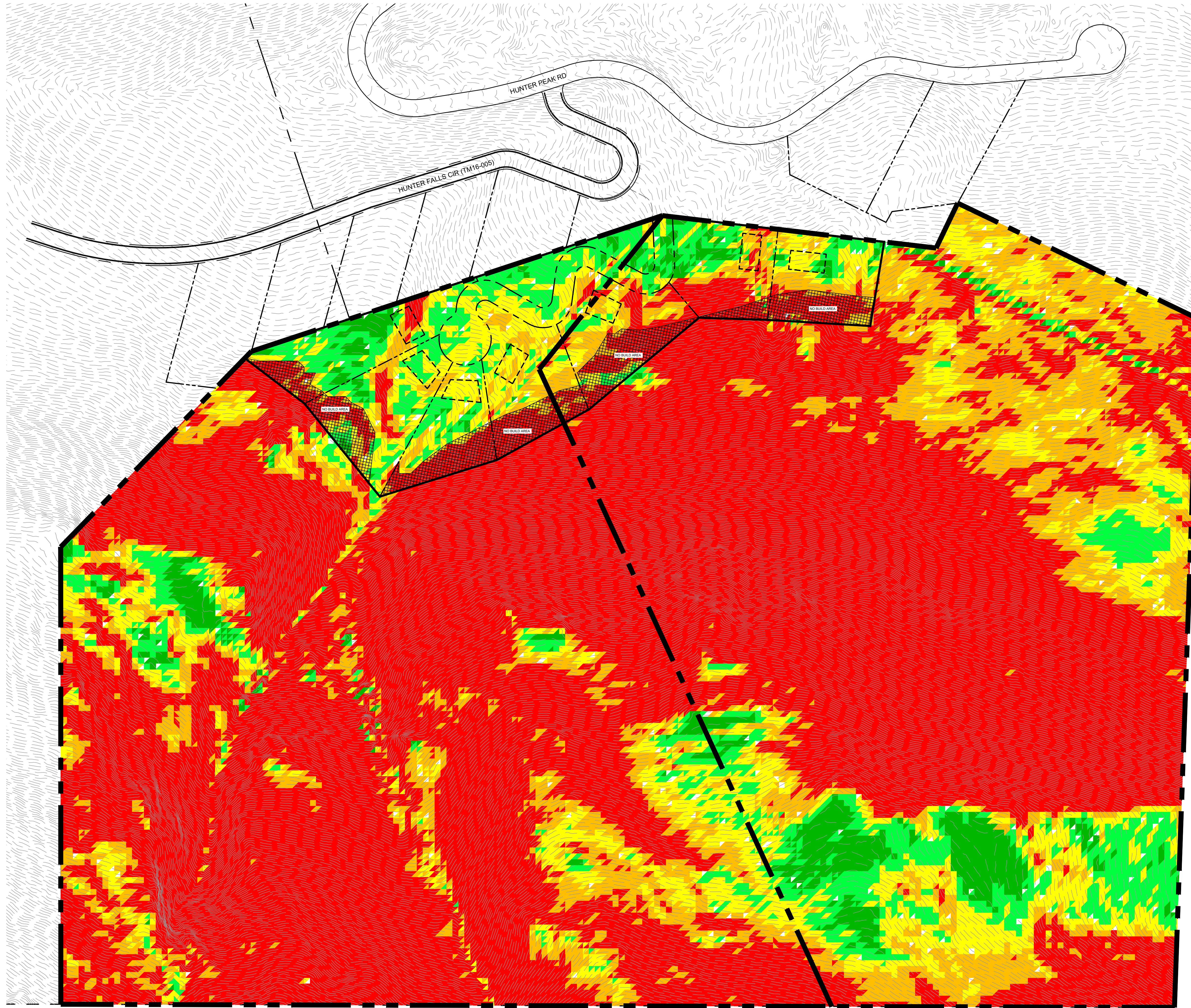

NOTE: EXISTING CONTOURS SHOWN WERE ACQUIRED FROM USGS AND DO NOT REPRESENT A SUMMIT ENGINEERING TOPOGRAPHICAL SURVEY.

| Slopes Table |             |             |               |
|--------------|-------------|-------------|---------------|
| Slope (%)    | Color       | Area (ac)   | % of Total    |
| 0 - 15       | Green       | 2.5         | 3.1%          |
| 15.1 - 20    | Light Green | 5.7         | 7.0%          |
| 20.1 - 25    | Yellow      | 9.1         | 11.2%         |
| 25.1 - 30    | Orange      | 11.6        | 14.2%         |
| 30+          | Red         | 52.6        | 64.5%         |
| <b>TOTAL</b> |             | <b>81.5</b> | <b>100.0%</b> |

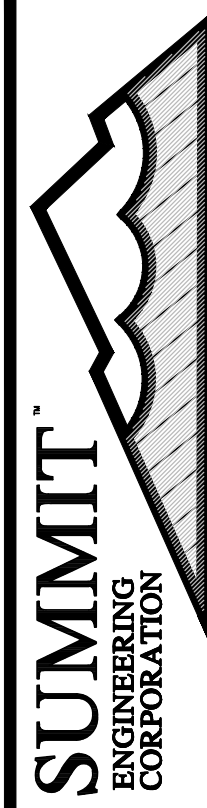
|                                                                                     |                                             |                                                                                 |                                                   |                           |                                                                                       |
|-------------------------------------------------------------------------------------|---------------------------------------------|---------------------------------------------------------------------------------|---------------------------------------------------|---------------------------|---------------------------------------------------------------------------------------|
|   | <b>SUMMIT</b><br>ENGINEERING<br>CORPORATION | 5405 MAE ANNE AVE. RENO, NV. 89523<br>PHONE: (775) 747-8550 FAX: (775) 747-8559 | DESIGNED BY:<br>DRAWN BY: cmenefee<br>CHECKED BY: | Copyright SUMMIT ENG 2023 | NEVADA                                                                                |
| <b>DAVID THOMPSON</b><br><b>APN 041-650-04 &amp; 041-650-05</b><br><b>SLOPE MAP</b> |                                             |                                                                                 |                                                   |                           |                                                                                       |
| WASHOE COUNTY                                                                       | WMPA23-0008 AND<br>WRZA23-0009<br>EXHIBIT F | SCALE<br>HORIZ: 1"=100'<br>VERT:                                                | REV.   DATE   DESCRIPTION   BY   APPD             | SHEET<br>1<br>of<br>1     | N:\DWG\SUB1143 ThompsonWoodchuck\Civil\Thompson_SlopeMap.DWG - 11:50 AM - 07-NOV-2023 |

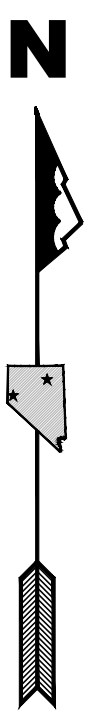
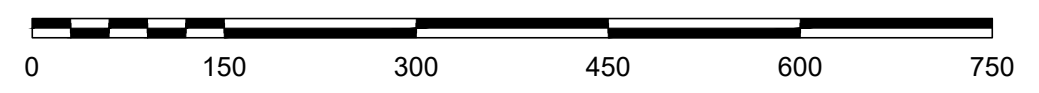
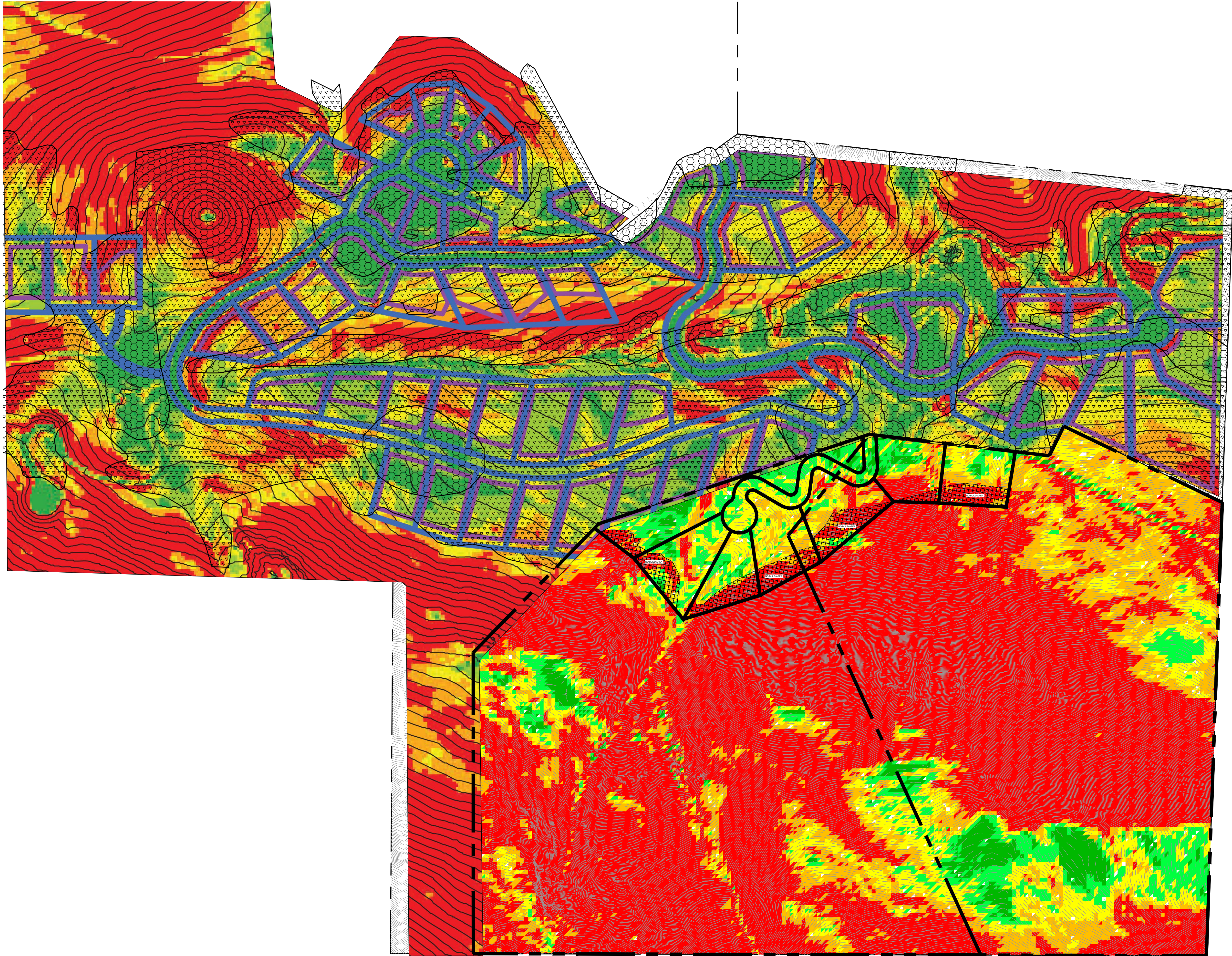

WASHOE COUNTY REGULATORY ZONING

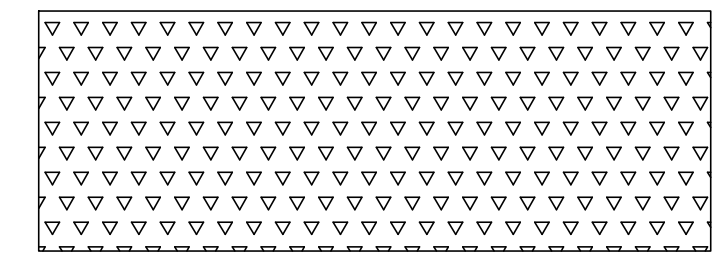

HIGH DENSITY RURAL (HDR)

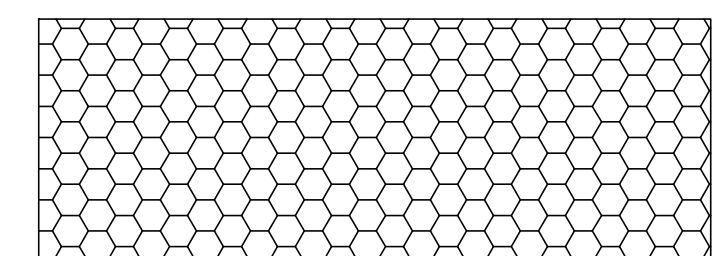

LOW DENSITY SUBURBAN (LDS)

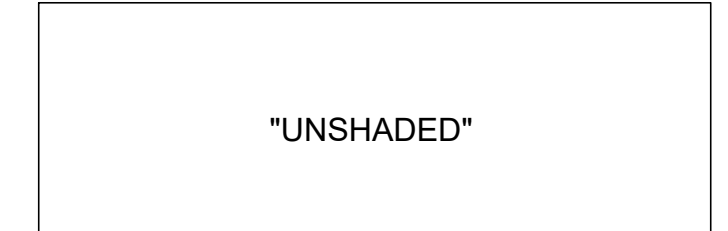

"UNSHADED"

GENERAL RURAL (GR)

NOTE: EXISTING CONTOURS SHOWN WERE ACQUIRED FROM USGS AND DO NOT REPRESENT A SUMMIT ENGINEERING TOPOGRAPHICAL SURVEY.

| Slopes Table |       |           |            |
|--------------|-------|-----------|------------|
| Slope (%)    | Color | Area (ac) | % of Total |
| 0 - 15       |       | 2.5       | 3.1%       |
| 15.1 - 20    |       | 5.7       | 7.0%       |
| 20.1 - 25    |       | 9.1       | 11.2%      |
| 25.1 - 30    |       | 11.6      | 14.2%      |
| 30+          |       | 52.6      | 64.5%      |
| TOTAL        |       | 81.5      | 100.0%     |

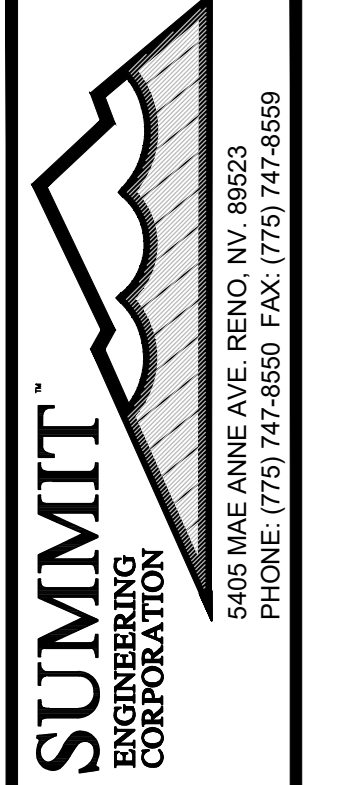

DESIGNED BY: cmenefee  
 DRAWN BY: cmenefee  
 CHECKED BY: Copy/right SUMMIT ENG 2023

DAVID THOMPSON  
 APN 041-650-04 & 041-650-05  
 SLOPE MAP

| SHEET                                                                                           | SCALE          | REV. | DATE | DESCRIPTION | BY | APPD |
|-------------------------------------------------------------------------------------------------|----------------|------|------|-------------|----|------|
| 1                                                                                               | HORIZ: 1"=150' |      |      |             |    |      |
| 1                                                                                               | VERT: 1"=10'   |      |      |             |    |      |
| JOB NO: N:\D\G\31143 Thompson\Woodchuck\Civil\Thompson_SlopeMap.Composite.DWG - 11:29 AM '08-NV |                |      |      |             |    |      |

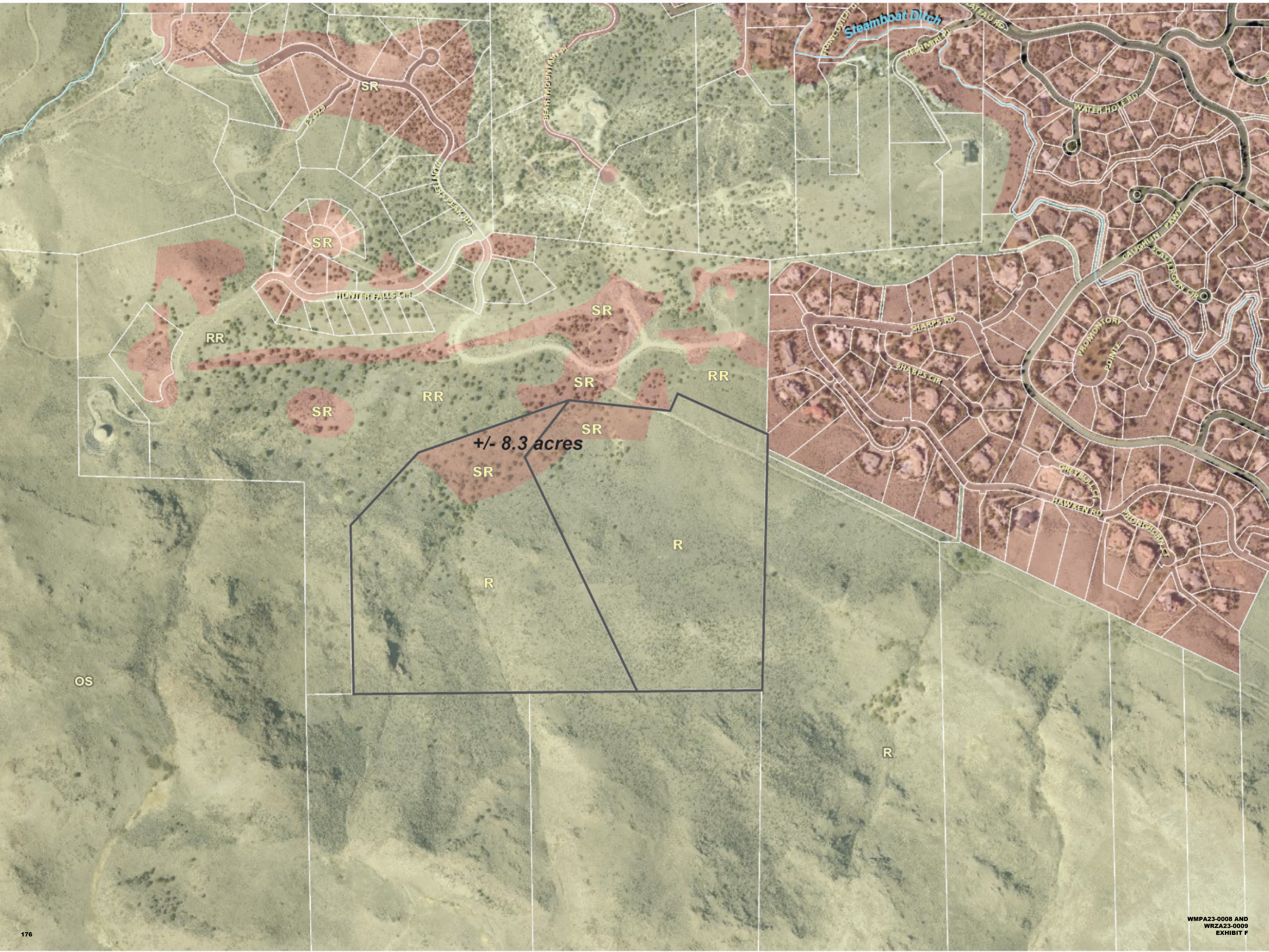

+/- 8.3 acres





OS

HDR

LDS

HDR

LDS

**+/- 8.3 acres**

LDS

GR

GR

GR

LDS

PSP

LDS

HUNTER FALLS CIR

Steamboat Ditch

WATER HOLE RD

SHAPPS RD

SHAPPS CIR

GREY WOLF CT

HAWKEN RD

ALONGHORNET

CALEDON TWPY

WINDMILL

PONYE

SCATTERED

LATEAU RD



TRUCKEE RIVER

MAYBERRY DR

Hunter Creek Reservoir

CAUGHLIN RANCH

PLATEAU RD

CAUGHLIN PKWY

PLUMB LN

S MCCARRAN BLVD

Michael D. Thompson Trailhead



Ridges at Hunter Creek

Project Area

SITE





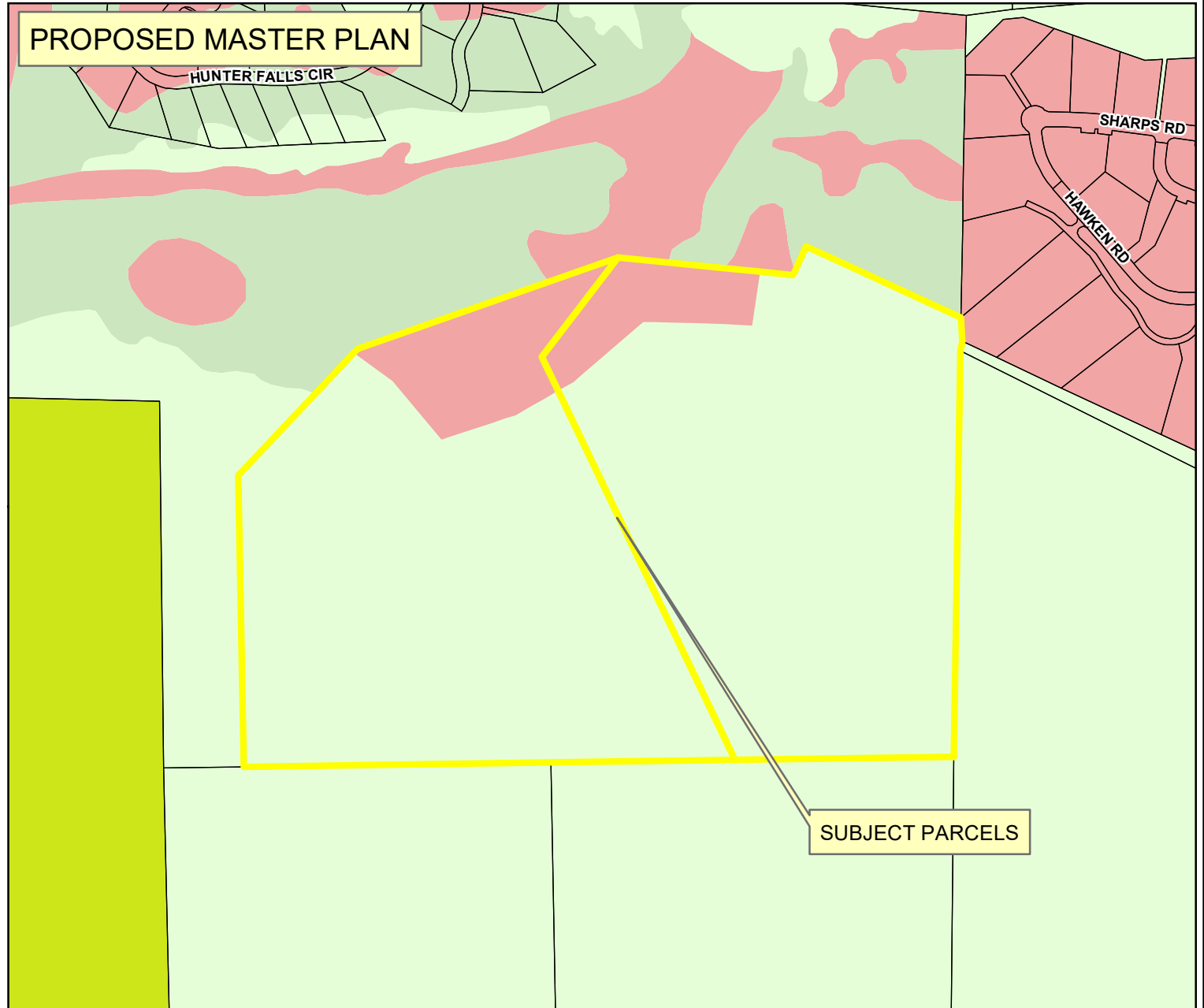
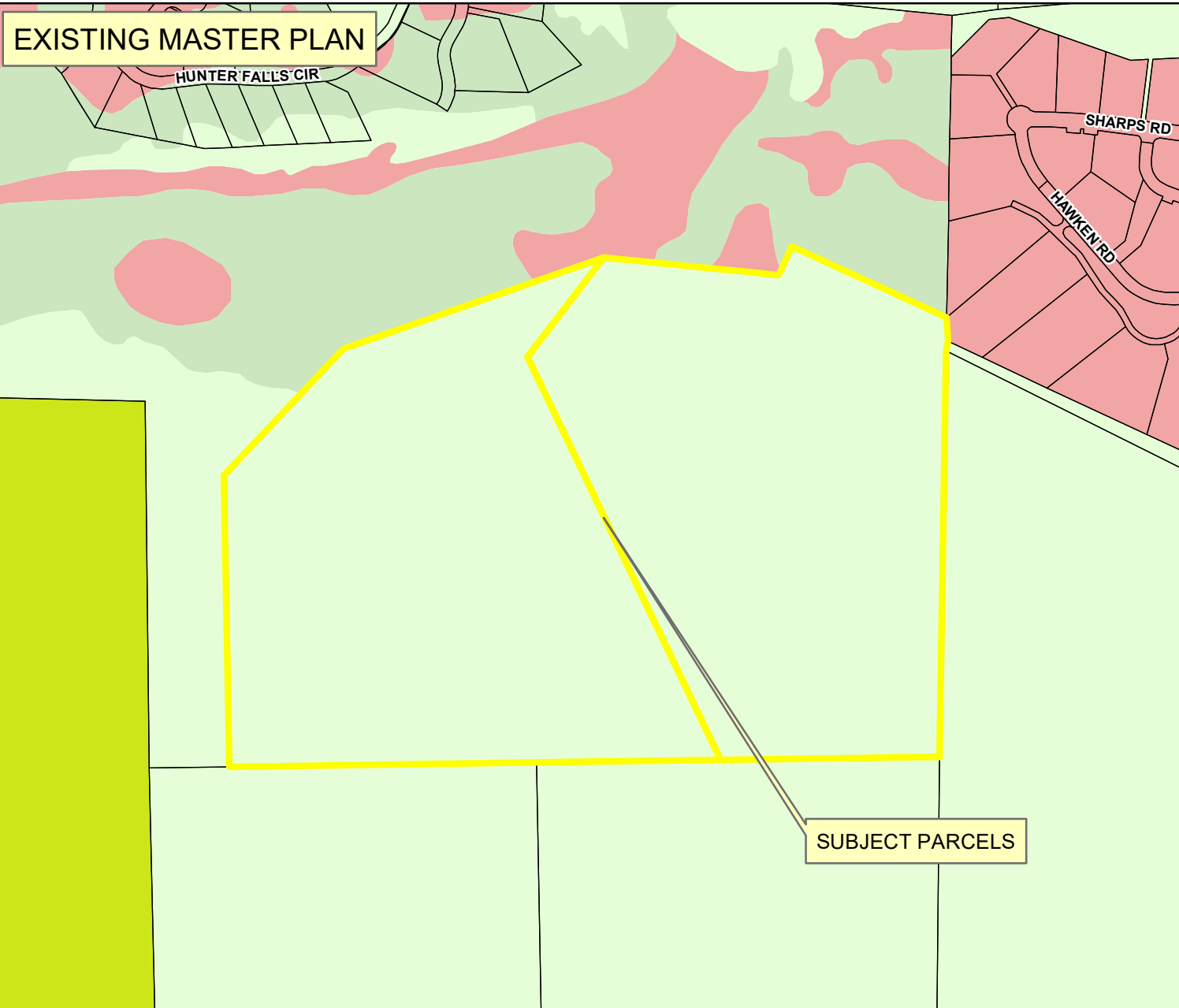

Village Green Park

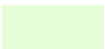

Lot Area



**SOUTHWEST PLANNING AREA  
WMPA23-0008; APN 041-650-04, 05**

- |                                                                                                          |                                                                                                  |
|----------------------------------------------------------------------------------------------------------|--------------------------------------------------------------------------------------------------|
|  RURAL                |  COMMERCIAL |
|  RURAL RESIDENTIAL    |  INDUSTRIAL |
|  SUBURBAN RESIDENTIAL |  OPEN SPACE |
|  URBAN RESIDENTIAL    |                                                                                                  |

NOTE: THE SCALE AND CONFIGURATION OF ALL INFORMATION SHOWN HEREON ARE APPROXIMATE ONLY AND ARE NOT INTENDED AS A GUIDE FOR DESIGN OR SURVEY WORK. REPRODUCTION IS NOT PERMITTED WITHOUT PRIOR WRITTEN PERMISSION FROM THE WASHOE COUNTY PLANNING AND DEVELOPMENT DIVISION.



**Community Services  
Department**

**WASHOE COUNTY  
NEVADA**  
1861

Post Office Box 11130  
Reno, Nevada 89520 (775) 328-3600

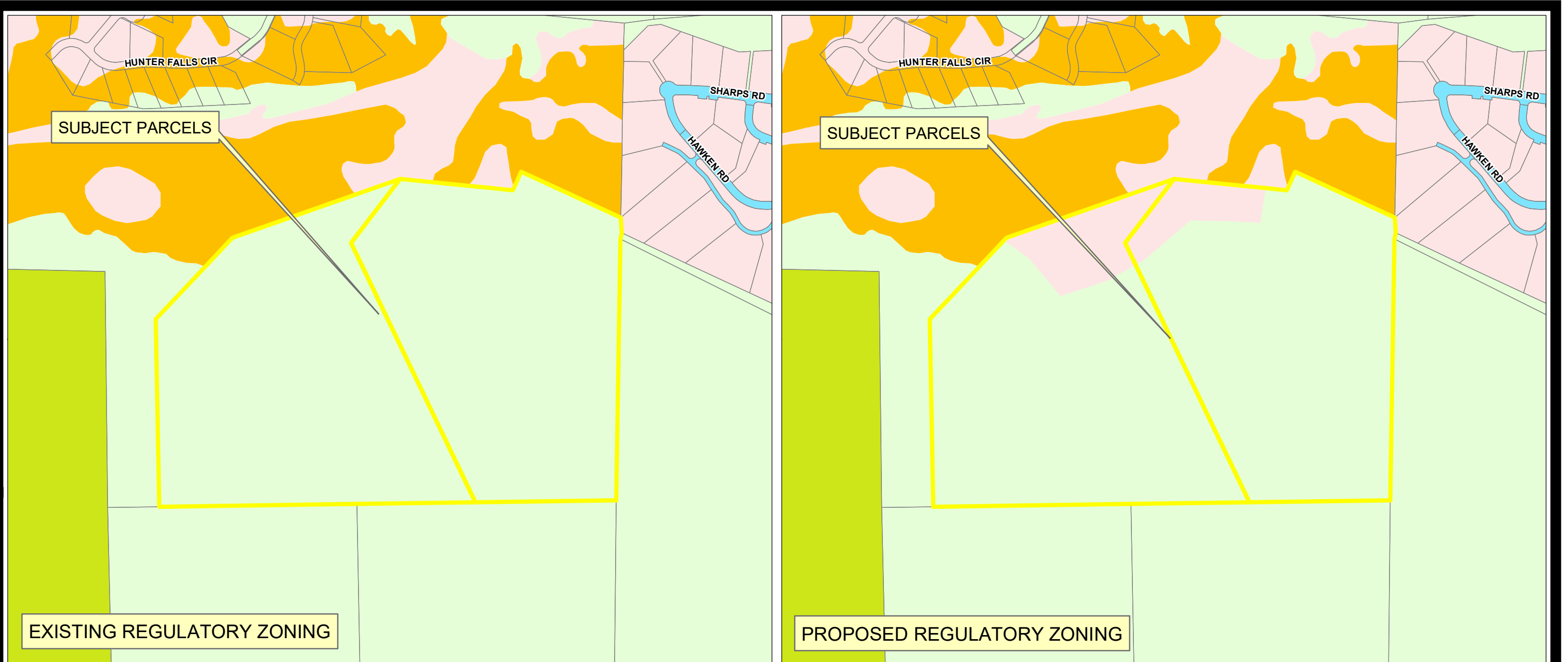

## SOUTHWEST WRZA23-0009; APN 041-650-04, 05

- |                                                                                                                                                                                                                                                                                                                                                                                                                                                                                                                                                                                                                                                                                                                                                                                                                                                                                                                                                       |                                                                                                                                                                                                                                                                                                                                                                                                                                                                                                                                                                                                                                                                                                                                                                                                                                                                                                                                     |                                                                                                                                                                                                                                                                                                                                                                                                                                                                                                                                                                                                                                                                                                                                                                                                                                                                                                                                               |                                                                                                                                                                                                                                                                                                                                                                                                                                                                                                                                                                                                                                                                                                                                                                                                                                                                                                                               |
|-------------------------------------------------------------------------------------------------------------------------------------------------------------------------------------------------------------------------------------------------------------------------------------------------------------------------------------------------------------------------------------------------------------------------------------------------------------------------------------------------------------------------------------------------------------------------------------------------------------------------------------------------------------------------------------------------------------------------------------------------------------------------------------------------------------------------------------------------------------------------------------------------------------------------------------------------------|-------------------------------------------------------------------------------------------------------------------------------------------------------------------------------------------------------------------------------------------------------------------------------------------------------------------------------------------------------------------------------------------------------------------------------------------------------------------------------------------------------------------------------------------------------------------------------------------------------------------------------------------------------------------------------------------------------------------------------------------------------------------------------------------------------------------------------------------------------------------------------------------------------------------------------------|-----------------------------------------------------------------------------------------------------------------------------------------------------------------------------------------------------------------------------------------------------------------------------------------------------------------------------------------------------------------------------------------------------------------------------------------------------------------------------------------------------------------------------------------------------------------------------------------------------------------------------------------------------------------------------------------------------------------------------------------------------------------------------------------------------------------------------------------------------------------------------------------------------------------------------------------------|-------------------------------------------------------------------------------------------------------------------------------------------------------------------------------------------------------------------------------------------------------------------------------------------------------------------------------------------------------------------------------------------------------------------------------------------------------------------------------------------------------------------------------------------------------------------------------------------------------------------------------------------------------------------------------------------------------------------------------------------------------------------------------------------------------------------------------------------------------------------------------------------------------------------------------|
| <ul style="list-style-type: none"> <li><span style="display: inline-block; width: 15px; height: 15px; background-color: #ffffcc; border: 1px solid black; margin-right: 5px;"></span> LOW DENSITY RURAL</li> <li><span style="display: inline-block; width: 15px; height: 15px; background-color: #ffff00; border: 1px solid black; margin-right: 5px;"></span> MEDIUM DENSITY RURAL</li> <li><span style="display: inline-block; width: 15px; height: 15px; background-color: #ffcc00; border: 1px solid black; margin-right: 5px;"></span> HIGH DENSITY RURAL</li> <li><span style="display: inline-block; width: 15px; height: 15px; background-color: #ffcccc; border: 1px solid black; margin-right: 5px;"></span> LOW DENSITY SUBURBAN / LDS2</li> <li><span style="display: inline-block; width: 15px; height: 15px; background-color: #ff9999; border: 1px solid black; margin-right: 5px;"></span> MEDIUM DENSITY SUBURBAN / MDS4</li> </ul> | <ul style="list-style-type: none"> <li><span style="display: inline-block; width: 15px; height: 15px; background-color: #ff6600; border: 1px solid black; margin-right: 5px;"></span> HIGH DENSITY SUBURBAN</li> <li><span style="display: inline-block; width: 15px; height: 15px; background-color: #ffcc99; border: 1px solid black; margin-right: 5px;"></span> LOW DENSITY URBAN</li> <li><span style="display: inline-block; width: 15px; height: 15px; background-color: #cc9966; border: 1px solid black; margin-right: 5px;"></span> MEDIUM DENSITY URBAN</li> <li><span style="display: inline-block; width: 15px; height: 15px; background-color: #993333; border: 1px solid black; margin-right: 5px;"></span> HIGH DENSITY URBAN</li> <li><span style="display: inline-block; width: 15px; height: 15px; background-color: #ff0066; border: 1px solid black; margin-right: 5px;"></span> GENERAL COMMERCIAL</li> </ul> | <ul style="list-style-type: none"> <li><span style="display: inline-block; width: 15px; height: 15px; background-color: #ff66ff; border: 1px solid black; margin-right: 5px;"></span> NEIGHBORHOOD/OFFICE COMMERCIAL</li> <li><span style="display: inline-block; width: 15px; height: 15px; background-color: #990099; border: 1px solid black; margin-right: 5px;"></span> TOURIST COMMERCIAL</li> <li><span style="display: inline-block; width: 15px; height: 15px; background-color: #cccccc; border: 1px solid black; margin-right: 5px;"></span> INDUSTRIAL</li> <li><span style="display: inline-block; width: 15px; height: 15px; background-color: #6666ff; border: 1px solid black; margin-right: 5px;"></span> SPECIFIC PLAN</li> <li><span style="display: inline-block; width: 15px; height: 15px; background-color: #00bfff; border: 1px solid black; margin-right: 5px;"></span> PUBLIC AND SEMI-PUBLIC FACILITIES</li> </ul> | <ul style="list-style-type: none"> <li><span style="display: inline-block; width: 15px; height: 15px; background-color: #00ff00; border: 1px solid black; margin-right: 5px;"></span> PARKS AND RECREATION</li> <li><span style="display: inline-block; width: 15px; height: 15px; background-color: #99ff00; border: 1px solid black; margin-right: 5px;"></span> OPEN SPACE</li> <li><span style="display: inline-block; width: 15px; height: 15px; background-color: #ccffcc; border: 1px solid black; margin-right: 5px;"></span> GENERAL RURAL</li> <li><span style="display: inline-block; width: 15px; height: 15px; background-color: #99cc99; border: 1px solid black; margin-right: 5px;"></span> GENERAL RURAL AGRICULTURAL</li> <li><span style="display: inline-block; width: 15px; height: 15px; background-color: #ccccff; border: 1px solid black; margin-right: 5px;"></span> WATER BODY/DRY LAKE</li> </ul> |
|-------------------------------------------------------------------------------------------------------------------------------------------------------------------------------------------------------------------------------------------------------------------------------------------------------------------------------------------------------------------------------------------------------------------------------------------------------------------------------------------------------------------------------------------------------------------------------------------------------------------------------------------------------------------------------------------------------------------------------------------------------------------------------------------------------------------------------------------------------------------------------------------------------------------------------------------------------|-------------------------------------------------------------------------------------------------------------------------------------------------------------------------------------------------------------------------------------------------------------------------------------------------------------------------------------------------------------------------------------------------------------------------------------------------------------------------------------------------------------------------------------------------------------------------------------------------------------------------------------------------------------------------------------------------------------------------------------------------------------------------------------------------------------------------------------------------------------------------------------------------------------------------------------|-----------------------------------------------------------------------------------------------------------------------------------------------------------------------------------------------------------------------------------------------------------------------------------------------------------------------------------------------------------------------------------------------------------------------------------------------------------------------------------------------------------------------------------------------------------------------------------------------------------------------------------------------------------------------------------------------------------------------------------------------------------------------------------------------------------------------------------------------------------------------------------------------------------------------------------------------|-------------------------------------------------------------------------------------------------------------------------------------------------------------------------------------------------------------------------------------------------------------------------------------------------------------------------------------------------------------------------------------------------------------------------------------------------------------------------------------------------------------------------------------------------------------------------------------------------------------------------------------------------------------------------------------------------------------------------------------------------------------------------------------------------------------------------------------------------------------------------------------------------------------------------------|

NOTE: THE SCALE AND CONFIGURATION OF ALL INFORMATION SHOWN HEREON ARE APPROXIMATE ONLY AND ARE NOT INTENDED AS A GUIDE FOR DESIGN OR SURVEY WORK. REPRODUCTION IS NOT PERMITTED WITHOUT PRIOR WRITTEN PERMISSION FROM THE WASHOE COUNTY PLANNING AND BUILDING DIVISION.



**Community Services  
Department**

**WASHOE COUNTY  
NEVADA**

1001 E Ninth St  
Reno, Nevada 89512 (775) 328-3600

SOURCE: Planning and Building Division

Path: G:\arcdata\planarea\swswRegzone\_working\WRZA23-0009\WRZA23-0009\_side\_by\_side.mxd

Date: 11/22/2023